



LINEAR ACTUATORS

CLA 30 – CLA 40 – CLA 50

CLB 30 – CLB 40 – CLB 50

Installation, operation and maintenance manual

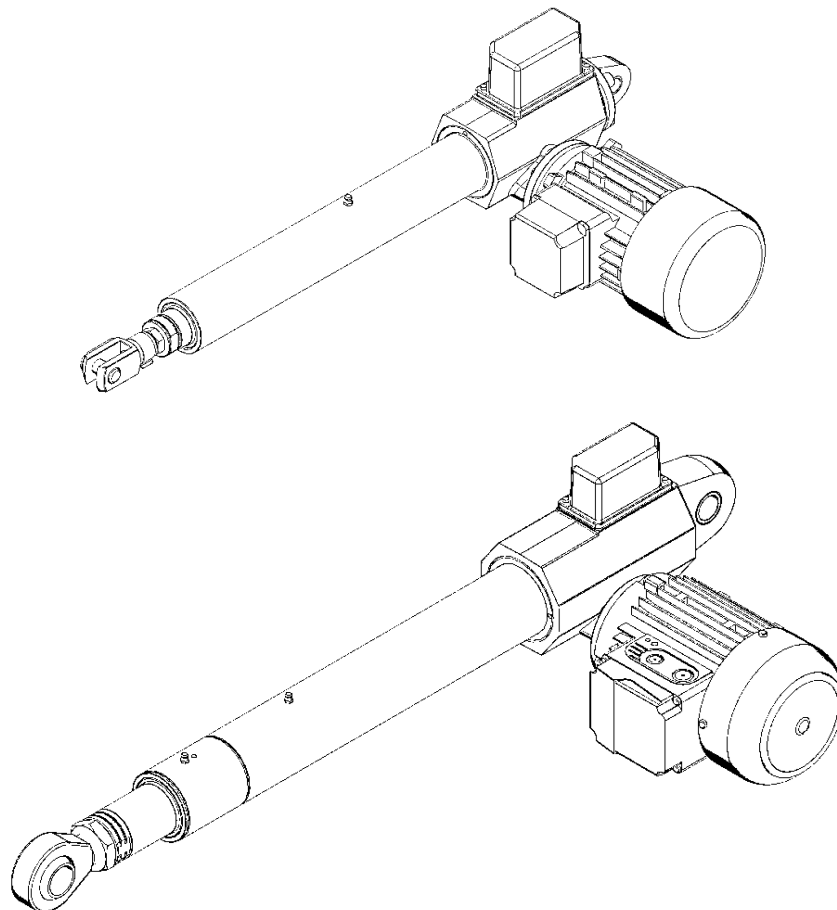

Publication: 16.30-40-50.E - Rev. 01 Date (M/Y) 05/19

Servomech S.p.A. Via M. Calari, 1 - 40011 Anzola dell'Emilia (BO) - ITALY

Ph: + 39 051 6501711 Fax: + 39 051 734574

www.servomech.com info@servomech.com



Read this manual before installing, operating or maintaining this actuator. Failure to follow safety precautions and instructions could cause actuator failure and result in serious injury, death or property damage.

This manual provides important information on how to work with the actuator safely and efficiently. The manual is part of the device, must always be kept in the device's direct proximity and should be available for personnel to read at any time. Failure to comply with the installation, use and maintenance instructions indicated in this manual will result in immediate termination of the warranty conditions of the actuator and completely relieve Servomech S.p.A. from any liability for damage caused to persons and / or property.

Servomech S.p.A. it does not assume direct or indirect responsibility for an improper use of the actuator, not respecting the performances of the actuator declared in the catalogs.

The manufacturer will not be liable for damage to the actuator or the equipment into which the actuator has been installed resulting from:

- disregarding this manual
- unintended use
- employment of untrained personnel
- unauthorized conversions
- technical modifications
- manipulation or removal of the screws on the device
- use of unapproved spare parts

The aforementioned conditions are therefore not contemplated and entail the immediate termination of the guarantee and the immediate decay of any responsibility on the part of Servomech S.p.A.

Servomech S.p.A. reserves the right to make changes to the actuators and this manual without giving any notice.

LINEAR ACTUATORS CLA30 - CLA40 - CLA50 – CLB30 – CLB40 –CLB50

Installation, operation and maintenance manual

Contents

1	MODELS COVERED BY THIS DOCUMENT	4
2	IDENTIFICATION OF THE MANUFACTURER AND THE PRODUCT	4
2.1	Identification of the manufacturer.....	4
2.2	Description of the product	4
2.3	Identification of the product	5
3	TRASPORT AND HANDLING	6
4	USE RESTRICTION	7
4.1	Intended use.....	7
4.1.1	Use restrictions.....	7
4.1.2	Standard operating conditions.....	8
4.1.3	Thermal limit	8
4.2	Personnel requirements / Qualifications	8
5	STORAGE.....	8
6	INSTALLATION	9
6.1	Safety warnings	9
6.2	Wiring of FC electric limit switches	10
6.3	Set up of FC electric limit switches.....	12
6.4	Wiring of POR 5k potentiometer	15
6.5	Set up of POR 5k potentiometer	17
6.6	Electric motor installation	19
6.7	Linear actuator installation	20
6.8	Installation of rod end fitting elements.....	21
7	COMMISSIONING AND USE	22
8	LUBRICATION.....	23
9	MAINTENANCE	24
9.1	Linear drive lubrication.....	24
9.2	Push rod guide lubrication	25

1 MODELS COVERED BY THIS DOCUMENT

The present manual is referred to following products:

Acme screw linear actuators: CLA30 – CLA40 – CLA50

Ball screw linear actuators: CLB30 – CLB40 – CLB50

2 IDENTIFICATION OF THE MANUFACTURER AND THE PRODUCT

2.1 Identification of the manufacturer

SERVOMECH S.p.A. S.U.

Via Monaldo Calari, 1

40011 Anzola dell'Emilia (BO)

ITALY

Ph. +39 051 6501 711

Fax. +39 051 7345 74

Website: www.servomech.com

e-mail: info@servomech.com

2.2 Description of the product

For all the technical characteristics of the product (performance, features, dimensions) refer to the technical catalog.

Main actuator components:

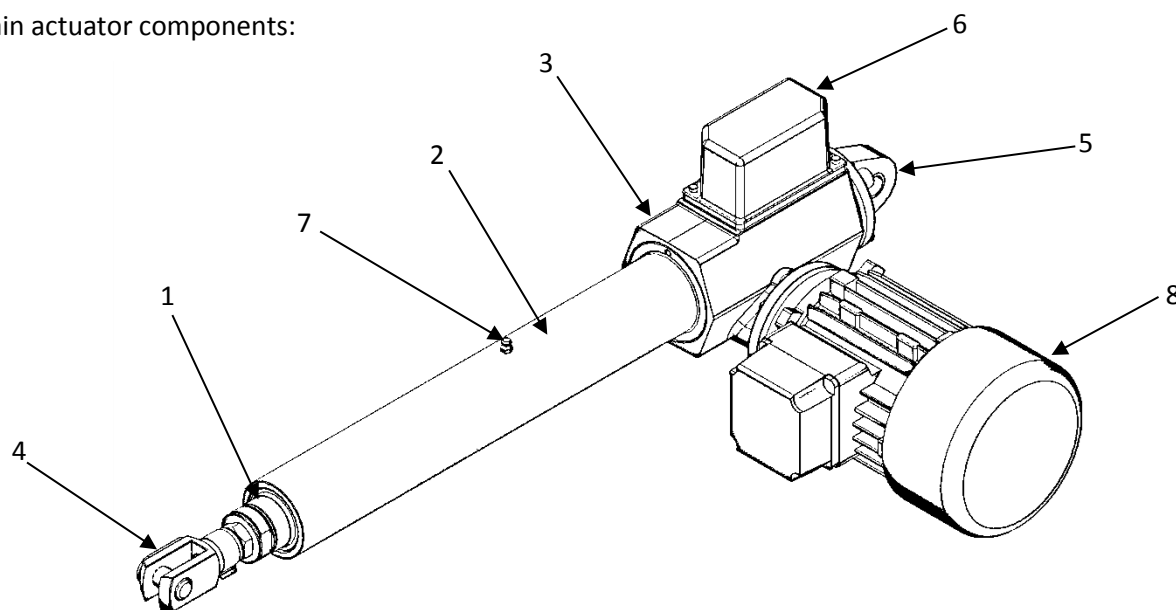

Figure 2.1 – Linear actuator components

- 1) Push rod
- 2) Protection tube
- 3) Gearbox housing
- 4) Rod end
- 5) Rear hinge
- 6) Limit switches box
- 7) Linear drive grease nipple
- 8) Electric motor

2.3 Identification of the product

Every SERVOMECH linear actuator is provided with a nameplate, as shown below, which allows the product identification and gives technical information about the product.

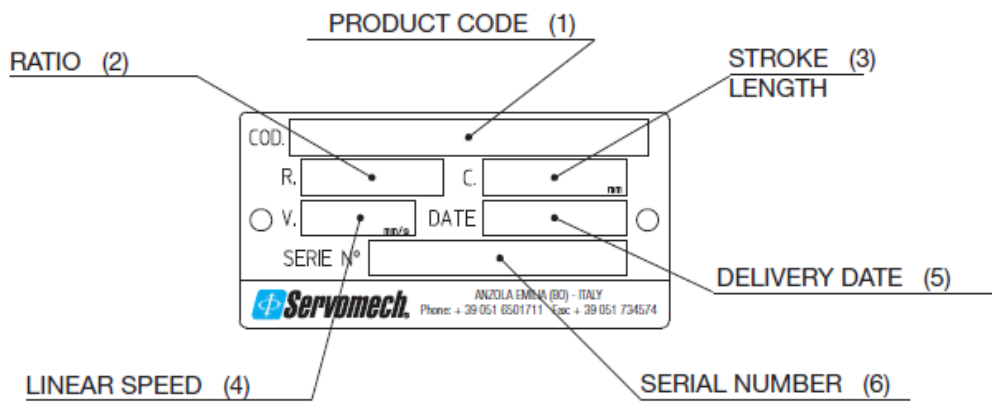

Figure 2.2 – Identification nameplate

- 1) **Product code**: is an alphanumeric code stating the type, size, ratio, version and stroke end switches of the linear actuator;
- 2) **Ratio**: is the ratio of the input drive;
- 3) **Stroke length**: is the stroke length in millimetres achievable by the actuator;
- 4) **Linear speed**: is the linear speed expressed in mm/s when the actuator is provided with electric motor; for an actuator without motor, this field is blank;
- 5) **Delivery date**: is the week/year of assembly (example: 30/13 = week 30 / year 2013) which usually coincides with the delivery date; this date is considered as reference for the warranty period;
- 6) **Serial number**: is the identification number of the actuator which identifies the exact design of the product even after a long time; the serial number is the essential reference for spare part orders.

3 TRASPORT AND HANDLING

- ⚠ It is recommended to pay attention and care during the handling and transport of linear actuators not to damage mechanical parts and / or accessories and to prevent risks for the personnel in charge of this activity.
- The packaging must be lifted and moved with care and in a safe way.
- For lifting and transporting the linear actuator, the push rod must be in retracted position.
- Lift the actuator from the housing and outer tube, supporting the motor during transport.
- DO NOT lift the actuator from the push rod and / or the motor.
- ⚠ In the case of CLB series actuators, the ball screw inside the actuator is NOT self-locking. Never lift the linear actuator upright from the push rod as the actuators could be back driven by its own weight.

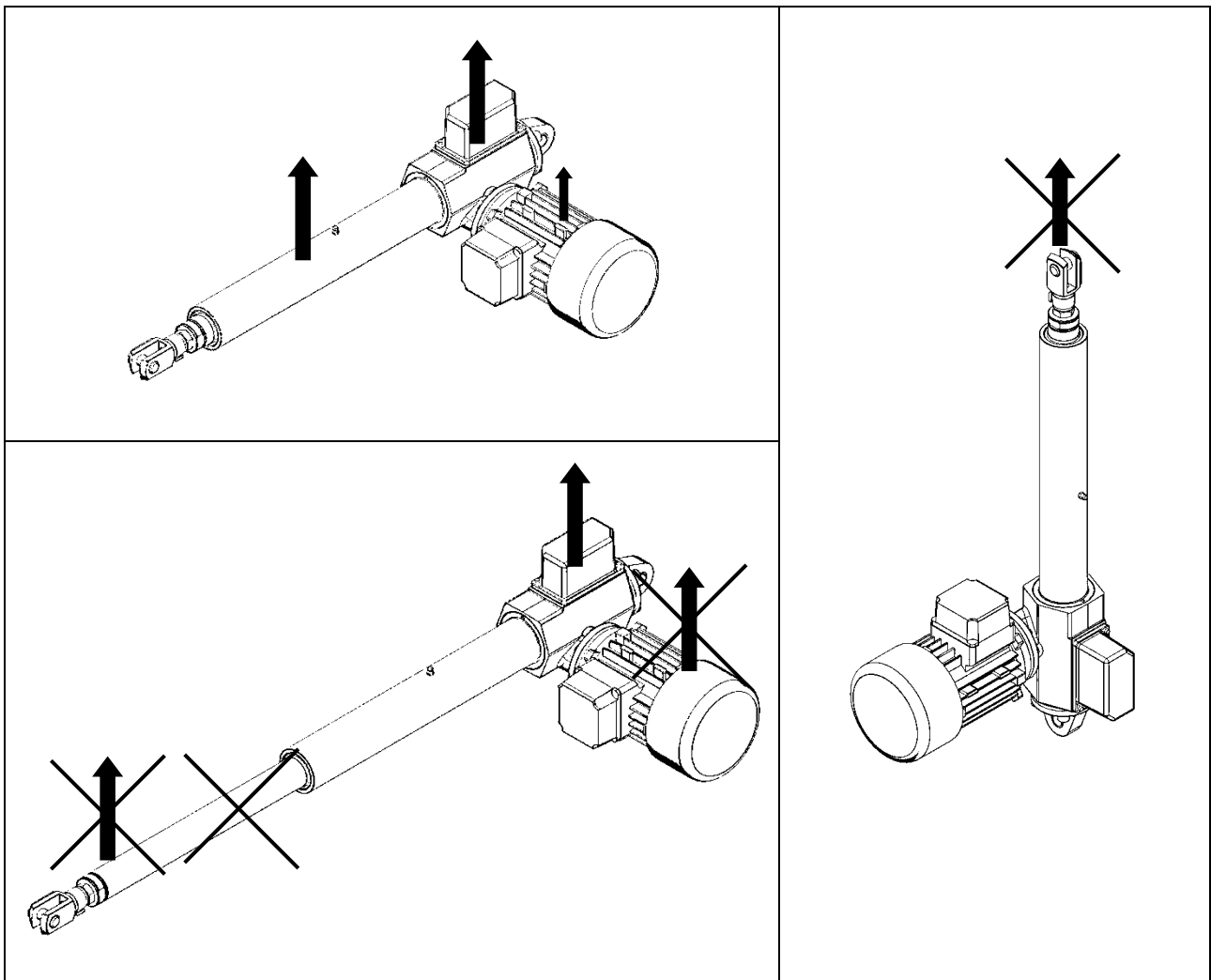

Figure 3.1 – Transport and handling

In case of doubt, consult SERVOMECH S.p.A. to get the appropriate information and prevent any kind of damage!

4 USE RESTRICTION

The information contained in this chapter provides important prescriptions for operating safely during all phases of the product's life.

Not knowing or not complying with these provisions can generate dangerous situations that could cause damage to equipment and risks for the safety of persons.

4.1 *Intended use*

Actuators are used to perform very different functions within machines. It is the responsibility of the machine builder to design the application in compliance with the laws in force in the specific sector and in the field of safety, in compliance with the requirements provided in the product catalog and in this manual.

- ⚠ ACTUATORS ARE ELECTRIC AXIS, WHATEVER DRIVER OR CONTROL WILL BE USED: THE SELECTION OF THE PRODUCT AS STROKE, SPEED, TYPE OF LIMIT SWITCHES, MOTOR AND BRAKE, MUST BE DONE ACCORDING TO THE BEHAVIOR EXPECTED, IN FUNCTION OF THE TYPE OF CONTROL CHOSEN AND THE STATIC AND DYNAMIC BEHAVIOR OF THE SYSTEM IN WHICH THE ACTUATOR IS PLACED!

The actuators have been designed and built to operate mobile parts of various types, shapes and construction, in the ways and within the limits set out in the descriptions and tables of the technical data in the catalog and in this user manual.

The actuators are designed to work with a purely axial applied load.

They must be subjected to the loading and speed conditions specified in the catalog.

Modification of parts of the actuator or replacement of components with different and non-original parts is not permitted. The replacement of components with original spare parts is carried out only by Servomech S.p.A.

Any different use is to be considered improper and therefore potentially dangerous for the safety of the operators, as well as such as to void the contractual guarantee.

In the event of particular processing requirements, we recommend consulting our sales department.

Every modification must be authorized by Servomech S.p.A. with written documents.

- ⚠ ANY OTHER USE OUTSIDE THAT THAT JUST DESCRIBED IS NOT PERMITTED BY SERVOMECH S.p.A.

4.1.1 Use restrictions

Actuators can not be used for unforeseen applications.

Any utilization of this device beyond its intended purpose may lead to potentially hazardous situations.

Therefore:

- Strictly adhere to all safety precautions and instructions in this operating manual.
- Do not allow this device to be subjected to weather conditions, strong UV rays, corrosive or explosive air media as well as other aggressive media (*).
- Do not modify, retool or change the structural design or individual components of the actuator.
- Never use the device outside of the technical application and operational limits.

(*) – THE USE OF THE ACTUATOR IN ABOVE CONDITIONS MUST BE PREVIOUSLY DECLARED AND AGREED WITH SERVOMECH, SINCE A SPECIAL EQUIPMENT OF THE PRODUCT MUST BE PROVIDED.

4.1.2 Standard operating conditions

The actuator must be used in an environment whose conditions comply with the provisions of Servomech S.p.A. The works necessary for obtaining and maintaining that conditions are in charge of the owner and, where applicable, are in charge of the end user.

The actuator must be installed and used indoor only, in dry area with environmental conditions as specified below:

- Temperature range +0°C ÷ +40°C
- Relative atmospheric humidity 5% ÷ 85%
- No build up of condensation
- △ THE USE OF THE ACTUATOR IN DIFFERENT CONDITIONS THAN JUST DESCRIBED MUST BE PREVIOUSLY DECLARED AND AGREED WITH SERVOMECH, SINCE A SPECIAL EQUIPMENT OF THE PRODUCT MUST BE PROVIDED.

4.1.3 Thermal limit

The actuator duty cycle permissible F_i [%] is the maximum working time expressed in percentage that the actuator can perform during the reference time period of 10 minutes, under rated load stated in the catalogue at ambient temperature 25°C, without risk of internal parts overheating.

$$F_i[\%] = \frac{\text{Max working time over 10 min}}{10 \text{ min}} \times 100$$

Linear drive	F_i [%]
Acme screw (CLA series)	30
Ball screw (CLB series)	100

For the proper operation of acme screw linear actuators (CLA series) do never exceed the permissible duty cycle limit.

4.2 Personnel requirements / Qualifications

This manual must be made available to the personnel in charge of installation, start up and use of the actuator. It is the responsibility of the machine builder:

- use personnel with the necessary qualifications for the installation and commissioning of the actuator;
- periodically check the qualification of the assigned personnel;
- check that the personnel in charge are aware of the contents of this manual.

5 STORAGE

- Do not store outside.
- Storage should be dry and dust-free.
- Keep away from any aggressive media.
- Protect from UV radiation.
- Avoid mechanical vibrations.
- Storage temperature: 0 to +50 °C.
- Relative atmospheric humidity: max. 95% (no build up of condensation).
- To store longer than 6 months, take care of moving the input shafts to prevent damages to sealings.
- Also check that all unpainted parts are adequately protected (oiled and /or greased) to prevent oxidation.

6 INSTALLATION

The operations described in the paragraphs of this chapter provide both electrical and mechanical connections of the actuator, as well as the execution of test motions at reduced speed and motor torque or with small displacement steps.

6.1 Safety warnings

- ⚠ MOTORS CANNOT BE CONNECTED DIRECTLY TO THE ELECTRICITY GRID. A PROPER CIRCUITS AND DEVICES FOR MOVEMENT MANAGEMENT ON BOTH DIRECTIONS IS REQUIRED. STROKE END LIMIT SWITCHES (MICROSWITCHES OR SENSORS) MUST BE CONTROLLED TO BE SURE THE LINEAR MOVEMENT OF THE ACTUATOR (DUE TO THE OPERATION OF THE MOTOR OR TO THE INERTIA OF THE MOVING PARTS) STOPS BEFORE TO REACH THE MECHANICAL STROKE END LIMITS. IN CASE THIS HAPPENS, THE ACTUATOR CAN BE LOCKED AND THE INTERNAL COMPONENTS CAN BE DAMAGED.
- ⚠ WHEN THE MOTORS MUST BE POWERED BY A CONVERTER (ELECTRIC DRIVE), THIS MUST BE CHOSEN BY QUALIFIED PERSONNEL.
- ⚠ IN CASE THERE ARE INVOLVED ELECTRONIC DRIVE AND CONTROL DEVICES ON THE ACTUATOR MOVING CONTROL, REFER TO MANUALS FOR ALL THE NECESSARY INFORMATION AND CORRECT INSTALLATION AND MAINTENANCE OF THE PRODUCT.
- ⚠ BEFORE TO PROCEED TO THE ELECTRIC CONNECTION, MAKE SURE THE SUPPLY VOLTAGE IS TURNED OFF.
- ⚠ BEFORE TO TURN-ON THE MOTOR, MAKE SURE THE ELECTRIC CONNECTIONS ARE TIGHTENED AND STABLE.
- ⚠ CHECK POWER SUPPLY CABLES NOT TO BE DAMAGED DURING THE COMMISSIONING. POWER SUPPLY CABLES MUST BE OUT OF HEAT SOURCES AND MOVING ORGANS.
- ⚠ DURING FUNCTIONING ARE PRODUCED MAGNETIC, ELECTRIC AND ELECTROMAGNETIC FIELDS. THIS MAY BE DANGEROUS FOR PEOPLE THAT USE CARDIAC STIMULATOR (PACEMAKER), IF NOT SUFFICIENT DISTANCE.
- ⚠ DO NOT DISCONNECT ANY CONNECTION DURING OPERATION OR IN PRESENCE OF SUPPLY VOLTAGE.
- ⚠ BEFORE TO TURN-ON THE MOTOR, MAKE SURE THE MECHANICAL CONNECTIONS OF THE ACTUATOR REMAIN TIGHTENED AND STABLE, ALSO DURING THE OPERATION.
- ⚠ DURING THE COMMISSIONING, UNEXPECTED MOVEMENT OF THE MOTOR MAY BE CAUSED BY:
 - WIRING ERRORS
 - MOUNTING ERRORS
 - DAMAGES ON POWER SUPPLY CABLES
 - HARDWARE OR SOFTWARE ERRORS
 - DRIVER PARAMETERS ERRORS
 - OPERATION IN CONDITIONS OUTSIDE THE SPECIFICATIONS PROVIDED BY THE CATALOG AND THIS MANUAL
- ⚠ MAKE SURE THE SAFETY PROTECTION OF THE MACHINE (MECHANICAL AND ELECTRICAL) ARE ACTIVE.
- ⚠ DURING OPERATION, TEMPERATURE OF THE EXTERNAL SURFACE OF MOTORS CAN REACH HIGH TEMPERATURES. HOT SURFACES ON ACTUATOR CAN CAUSE BURNS AND SHOULD NOT BE TOUCHED.

6.2 Wiring of FC electric limit switches

The electric stroke end switches allow to limit the actuator stroke avoiding to exceed the extreme positions (Lc or La) and reach the mechanical stops and in this way preventing possible damage.

The electric stroke end switches consists of two normally closed miniature electric switches that are fixed on the actuator housing and operated by cams.

The cams are driven by the acme or ball screw through a two-stage gear transmission. The first stage consists of a worm gear with constant ratio. The second stage consists of a cylindrical straight-tooth gear with ratio that depends on the maximum actuator stroke. To set up the actual actuator working stroke, the rod shall be positioned in the required position (extended actuator or retracted actuator) and set the position of the relevant cam around the support tube, turning and fixing it in the right position.

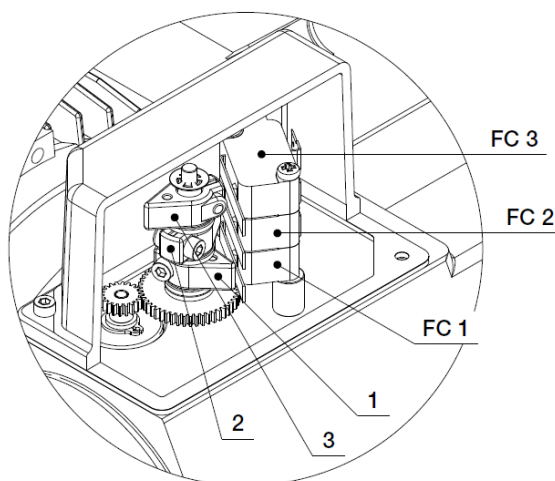

CAM 1 operates the switch **FC 1**, which corresponds to the retracted actuator (Lc) stopping position, while **CAM 2** operates the switch **FC 2**, which corresponds to the extended actuator (La) stopping position.

The entire assembly – switches, cams and cam driving transmission - is inside a sealed box.

The electric stroke end switches must be connected to the electric control circuit as shown in the wiring diagram on the left to guarantee motor switch off and to prevent damage to the actuator and to the application equipment. The electric stroke end switches are supplied already wired with a multicore cable PVC 4x0.75mm², standard length 1.5 m coming out of the box through a cable gland. The standard wiring is with NC contact, on request the switches are wired for NO contact.

In case an electric signal is required to identify any intermediate position of the push rod (between Lc and La), in addition to the two switches FC 1 and FC 2 an extra switch **FC 3**, mounted above the first two and operated by the relevant **CAM 3**, can be supplied.

- ⚠ **WARNING!** The push rod position determined by the switch FC 3 while the push rod is extending is different from the push rod position determined by the switch FC 3 while the push rod is retracting. It is therefore necessary to verify the difference between the two positions, by direct check or asking SERVOMECH, to evaluate the compatibility with the application requirements.

The switch FC 3 is supplied with normally CLOSED contact (NO contact on request) already wired with a multicore cable 2 x 0.75 mm², standard length 1.5 m. The wire colours are BLUE and BROWN.

The wiring diagram is shown below.

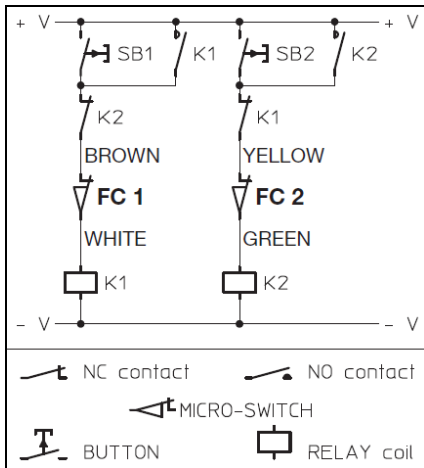

ELECTRIC SWITCH – TECHNICAL FEATURES			
<p>FC3: BROWN FC 2: YELLOW FC 1: BROWN (not wired) FC3: BLUE FC 2: GREEN FC 1: WHITE</p>			
Contact	NC (NO upon request)		
Voltage	250 V AC	125 V AC	125 V DC
Current (resistive load)	16 A	16 A	0.6 A
Current (inductive load)	10 A	10 A	0.6 A

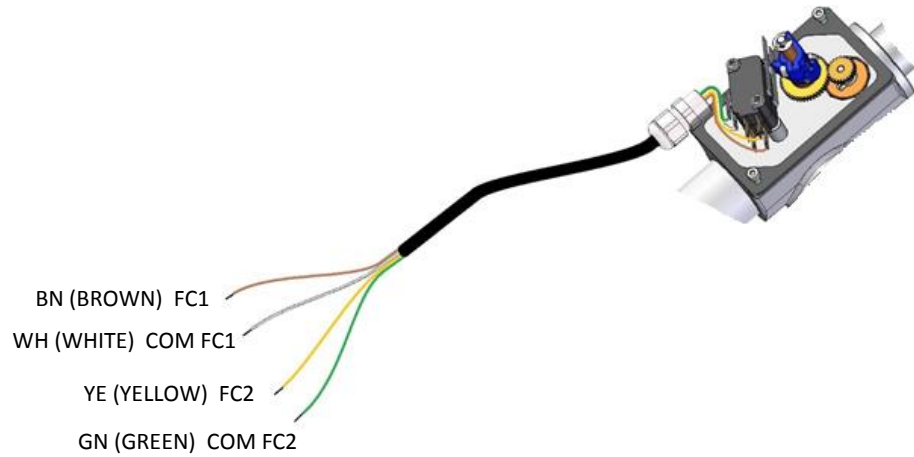

⚠ STROKE END LIMIT SWITCHES MUST BE CONTROLLED TO BE SURE THAT THE ACTUATOR STOPS BEFORE THE MECHANICAL STROKE END LIMITS. IN CASE THIS HAPPENS, THE ACTUATOR CAN BE LOCKED AND THE INTERNAL COMPONENTS CAN BE DAMAGED.

6.3 Set up of FC electric limit switches

- ⚠ WITH POTENTIOMETER OPTION, FIRSTLY ADJUST THE POTENTIOMETER, THEN ADJUST THE LIMIT SWITCHES CAMS.

The cams that actuate the limit switches start from the rotation of the acme / ball screw inside the actuator. The following figure shows the relationship between the direction of advance of the push rod and the direction of rotation of the shaft on which the cams are fixed.

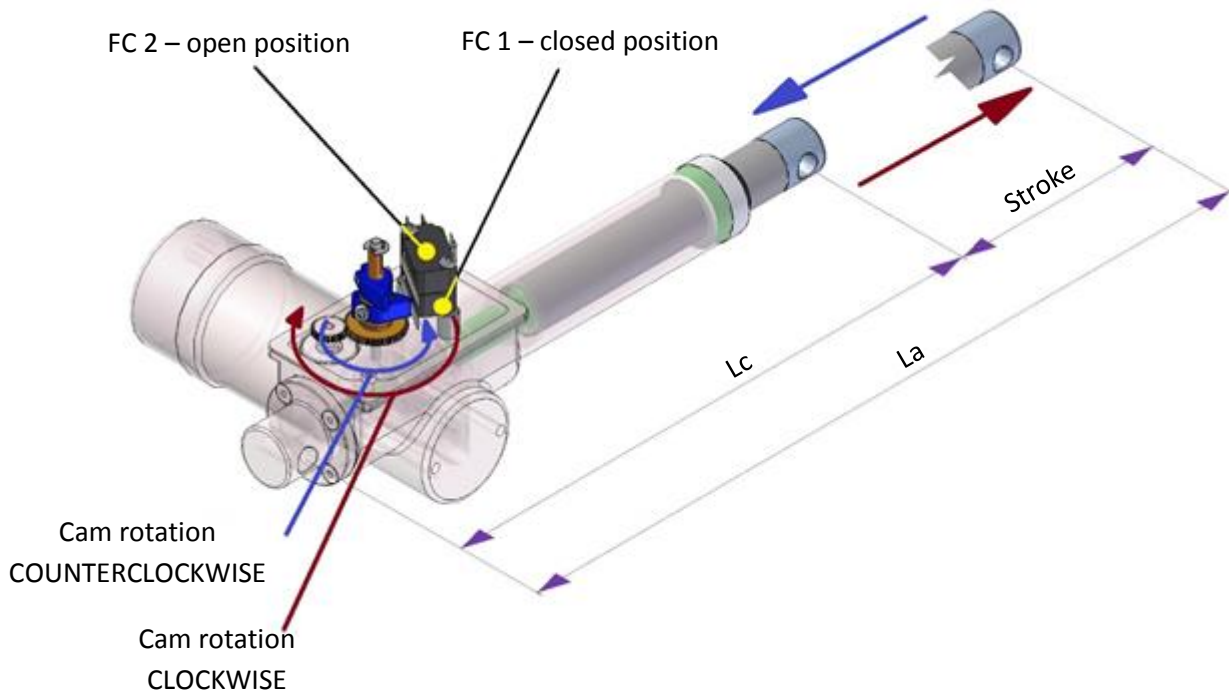

- ⚠ IN CASE OF ACTUATORS WITHOUT ANTI-ROTATION DEVICE, AVOID ANY PUSH ROD ROTATION, CAUSING CHANGES OF ITS AXIAL POSITION!
IF THIS HAPPENS, THE RELATION BETWEEN AXIAL POSITION OF PUSH ROD AND SWITCHES SETTING WILL BE LOST. IF A WRONG ACTION OCCURS, OR IN CASE OF DOUBT, PLEASE REPEAT THE SET UP OF THE LIMIT SWITCHES FOLLOWING THE SET-UP INSTRUCTIONS BELOW.

SET-UP INSTRUCTIONS

- The switch SW1 is operated by the cam CAM1 and fixes the required actuator retracted position.
- The switch SW2 is operated by the cam CAM2 and fixes the required actuator extended position.
- In case the actuator is supplied with three switches, the switch SW3 is operated by the cam CAM3 fixing an intermediate position.

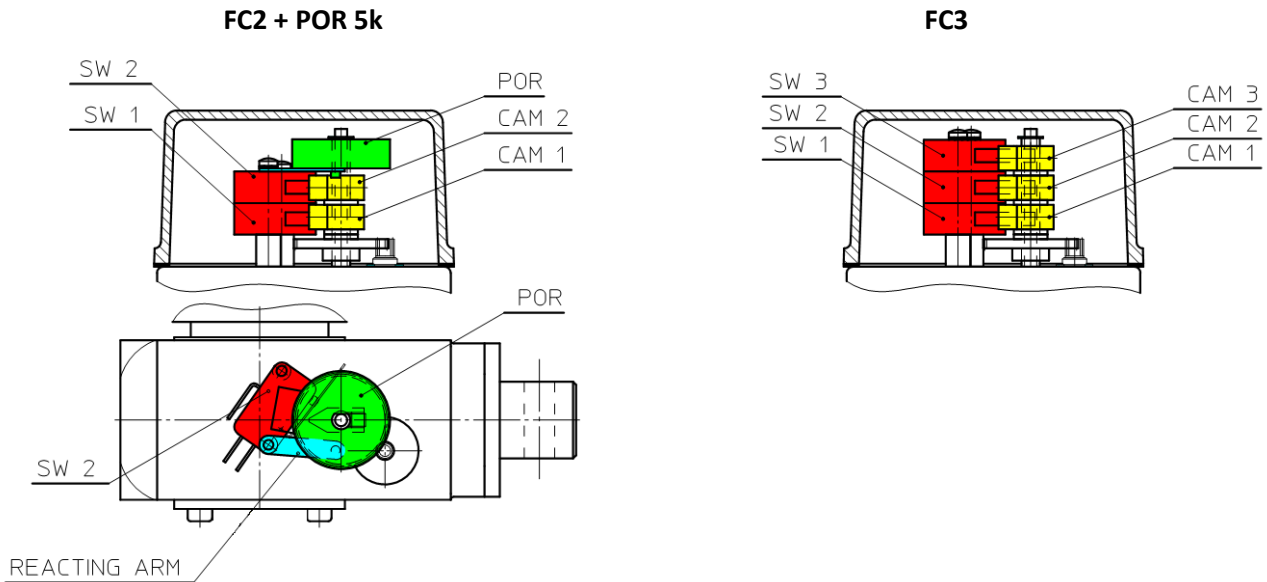

1. Open the switches box cover

- Before removing the switches cover, make sure that the cables are free by unscrewing the threaded glands, to avoid to break the welded contacts between the wires and switches or the potentiometer pins.
- Then unscrew two fixing screws and remove the cover.

2. Release the cam fixing screws on the vertical shaft

- ⚠ BEFORE CONTINUE, BE SURE TO PREVENT THE PUSH ROD ROTATION! THIS CONDITION IS ABSOLUTELY NECESSARY TO MAKE A CORRECT SET-UP. IN CASE OF ACTUATOR WITH ANTI-ROTATION DEVICE, THE PUSH ROD ROTATION IS ALREADY AVOIDED.

3. Set up of CAM1 for switch SW1 to fix the required actuator retracted position

- Gradually power on the electric motor of the actuator, until the push rod reaches the closed position required by the application. Do not exceed the limit dimensions L_c (retracted actuator) stated on the check sheet or technical catalogue.
- In this position, the actuator length must be greater or, at least, equal to the dimension L_c .
- Turn **anti-clockwise** the lower cam CAM1 until the lower switch SW1 is operated.
- Fix the cam CAM1 by screwing the fixing screw.

4. Set up of CAM2 for switch SW2 to fix the required actuator extended position

- Gradually power on the electric motor of the actuator, until the push rod reaches the extended position required by the application. Do not exceed the limit dimensions L_a (extended actuator) stated on the check sheet or technical catalogue.
- In this position, the actuator length must be lower or, at maximum, equal to the dimension L_a .
- Turn clockwise the upper cam CAM2 until the upper switch SW2 is operated.
- Fix the cam CAM2 by screwing the fixing screw.

5. Set up of CAM3 for switch SW3 to fix the required actuator intermediate position

Any intermediate position can be fixed with the upper SW3 operated with the cam CAM3 in the same way as described in the above points 3 and 4.

- ⚠ **WARNING!** The push rod position determined by the switch FC 3 while the push rod is extending is different from the push rod position determined by the switch FC 3 while the push rod is retracting.

6. Set-up final check

- Connect the switches to the power supply board.
- Switch on the motor and do some complete working stroke to verify if the set-up is correct.
- If the set-up is not correct, cut off the power supply and repeat the set-up procedure starting from point 2.

7. Switches box cover closing

- Check the right position of the sealing between cover and actuator housing.
- Do not pull the connecting cables to avoid breaking the wires fixing welded contacts.
- Fix the cover with the two fixing screws. Screw the cables glands.

6.4 Wiring of POR 5k potentiometer

The rotary potentiometer is an absolute transducer whose output signal is proportional to the distance between the reference position (“ZERO” position) and the current position of the actuator push rod.

The rotary potentiometer gives an analog output signal.

The rotary potentiometer is mounted on the same shaft that supports the cams which operate the stroke end switches and therefore it is driven by the same gear transmission. While the part of the potentiometer which contains the electric resistance remains stationary, because it is connected to the actuator housing through a reaction arm, the other part with the cursor inside is driven by the transmission shaft and rotates.

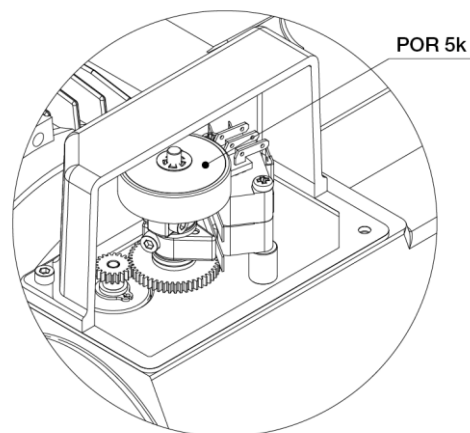

Electric features of the rotary potentiometer **POR 5k**:

Resistive element	Conductive plastic
Electrical angle	340°
Nominal resistance	5kΩ
Resistance tolerance	+/- 20%
Linearity	+/- 2%
Max power supply voltage at 40°C	35Vdc
Suggested cursor current	< 0.1 μA
Working temperature	-25°C ÷ +75°C
Output	Multicore cable 4 × 0.25 mm ² length 1.5 m

Recommended wiring connection (suggested power supply: 10 V):

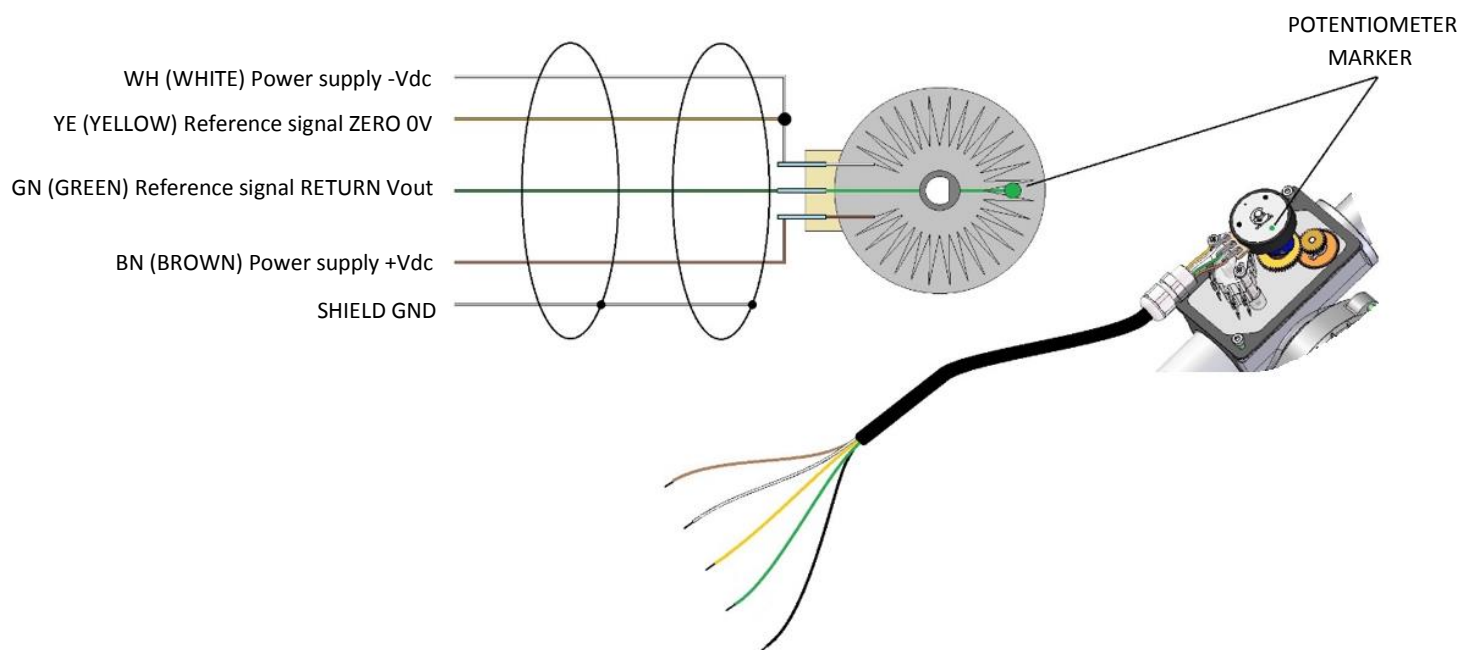

Rotary potentiometer working angle (actuator not installed in the machine)

⚠ WARNING: the working angle of the potentiometer depends on the the actuator model and its stroke.

Ref.: R_1 = 1-start acme screw, R_2 = 2-start acme screw

Example: CLA 30 RL1 C200 = stroke 200mm and 1-start acme screw

CLA 30		Ratio	
		R_1	R_2
Stroke	C100	259.6°	129.8°
	C200	276.9°	259.6°
	C300	283.2°	288.5°
	C400	230.8°	276.9°
	C500	288.5°	236.0°
	C600	-	283.2°
	C700	-	201.9°
	C800	-	230.8°

CLA 40		Ratio	
		R_1	R_2
Stroke	C100	207.7°	103.8°
	C200	221.5°	207.7°
	C300	226.6°	230.8°
	C400	184.6°	221.5°
	C500	230.8°	276.9°
	C600	276.9°	226.6°
	C700	-	264.3°
	C800	-	184.6°

CLA 50		Ratio	
		R_1	R_2
Stroke	C100	173.1°	86.5°
	C200	256.4°	173.1°
	C300	276.9°	259.6°
	C400	251.7°	256.4°
	C500	192.3°	230.8°
	C600	230.8°	276.9°
	C700	269.2°	220.3°
	C800	-	251.7°

CLB 30		Ratio	
		R_1	R_2
Stroke	C100	207.7°	103.8°
	C200	221.5°	207.7°
	C300	226.6°	230.8°
	C400	184.6°	221.5°
	C500	230.8°	276.9°
	C600	276.9°	226.6°
	C700	-	264.3°
	C800	-	184.6°

CLB 40		Ratio	
		R_1	R_2
Stroke	C100	173.1°	103.8°
	C200	256.4°	207.7°
	C300	276.9°	230.8°
	C400	251.7°	221.5°
	C500	192.3°	276.9°
	C600	230.8°	226.6°
	C700	269.2°	264.3°
	C800	-	184.6°

CLB 50		Ratio	
		R_1	R_2
Stroke	C100	103.8°	51.9°
	C200	207.7°	103.8°
	C300	230.8°	155.8°
	C400	221.5°	207.7°
	C500	276.9°	259.6°
	C600	226.6°	230.8°
	C700	264.3°	269.2°
	C800	184.6°	221.5°

⚠ WARNING: COMBINATIONS NOT INDICATED IN THE TABLE ARE NOT FEASIBLE.

6.5 Set up of POR 5k potentiometer

- ⚠ SET UP THE POTENTIOMETER BEFORE TO ADJUST THE CAMS LIMIT SWITCHES.
- ⚠ In case of actuator with anti-turn device option (AR), the POR 5k potentiometer is supplied already SET UP by the factory.

SET-UP INSTRUCTIONS

1. Open the switches box cover

- Before removing the switches cover, make sure that the cables are free by unscrewing the threaded glands, to avoid to break the welded contacts between the wires and switches or the potentiometer pins.
- Then unscrew two fixing screws and remove the cover.

2. Recognize the extreme positions of the transducer

Look at the little dot under the potentiometer trademark.

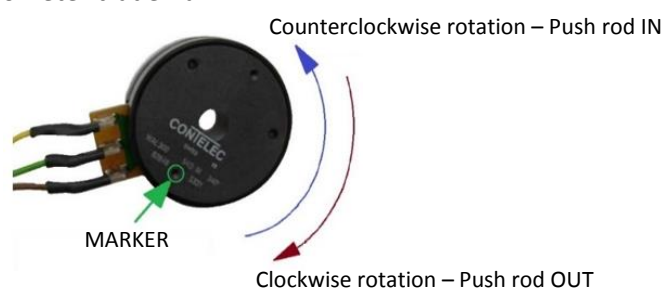

- When the transducer is rotated counterclockwise, and the dot is near the terminal with the yellow and white wires, the transducer is on the MINIMUM RESISTANCE position.
- When the transducer is rotated clockwise, and the dot is near the terminal with the brown wire, the transducer is on the MAXIMUM RESISTANCE position.
- ⚠ IF THE MARKER IS OVER THE EXTREME LIMIT POSITIONS ABOVE MENTIONED, THE POTENTIOMETER EXITS THE ELECTRICAL WORKING ANGLE CAUSING THE SIGNAL INTERRUPTION!

3. Rotary potentiometer setup

- Depending on its current position, screw in or unscrew, by hand, the push rod in order to be at about half of stroke.
- Make the actuator run by rotating the auxiliary input shaft or by powering the electric motor, until the ohmmetric value between the wires green and yellow is **(30 ... 35) Ω** (minimum resistance position).
 - ⚠ WARNING! DURING THIS OPERATION, THE LC (RETRACTED ATUATOR) AND LA (EXTENDED ACTUATOR) POSITIONS, INDICATED ON THE CHECK SHEET SUPPLIED IN ATTACHMENT TO THE ACTUATOR OR IN THE CATALOGUE, MUST NOT BE EXCEEDED! IF NECESSARY, SCREW IN OR UNSCREW THE PUSH ROD AGAIN.
- Screw the push rod in, in order to reach the Lc (RETRACTED ACTUATOR) position. With this operation, the rotary potentiometer setting is finished and, **from this moment, the push rod rotation must be avoided!** Any push rod rotation will invalid the already done rotary potentiometer setting.
- Connect the rotary potentiometer to the control circuit. Power the motor on, in order to extend the actuator first and then to retract it.

⚠ WARNING! DURING THIS OPERATION, THE LC (RETRACTED ACTUATOR) AND LA (EXTENDED ACTUATOR) POSITIONS, INDICATED ON THE CHECK SHEET SUPPLIED IN ATTACHMENT TO THE ACTUATOR OR IN THE CATALOGUE, MUST NOT BE EXCEEDED!

- While the actuator is in motion, check if the setup fit the requirements.
- Close the cover and tight the cable gland.

⚠ WARNING! THE POTENTIOMETER SETUP REMAINS VALID UNTIL THE PUSH ROD IS NOT ROTATED!

4. Rotary potentiometer fine adjustment

If a fine adjustment of the potentiometer is necessary, it is possible to act on the reaction arm which fixes the potentiometer body as shown in the following figure.

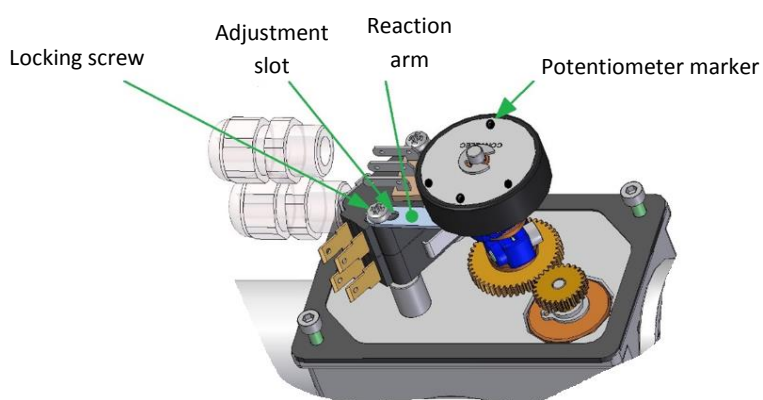

- Loose the locking screw.
- Adjust the angular position of the potentiometer through the adjustment slot.
- Tighten the locking screw.

6.6 Electric motor installation

Connect the motor to the power unit of the plant or to the driver according to the following wiring diagrams:

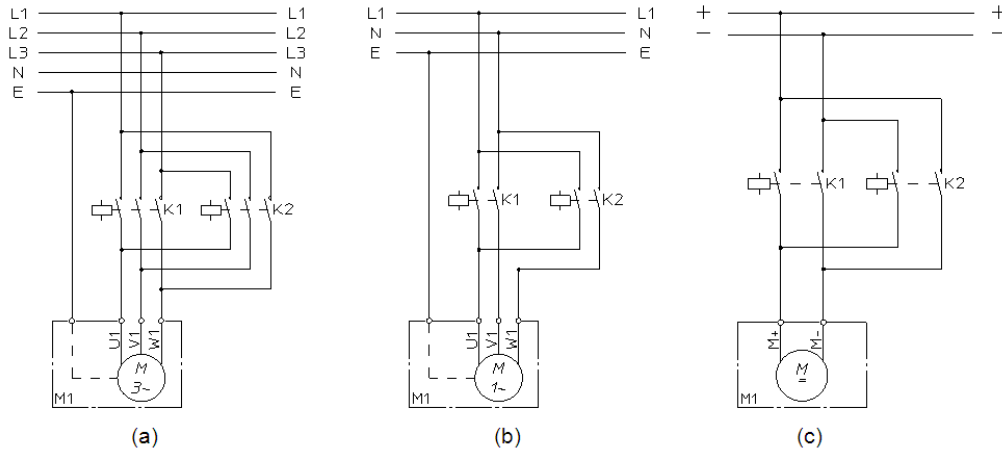

Figure 6.1 – Electric wiring diagrams to power supply
(a) AC 3-phase motor; (b) AC 1-phase motor; (c) DC motor

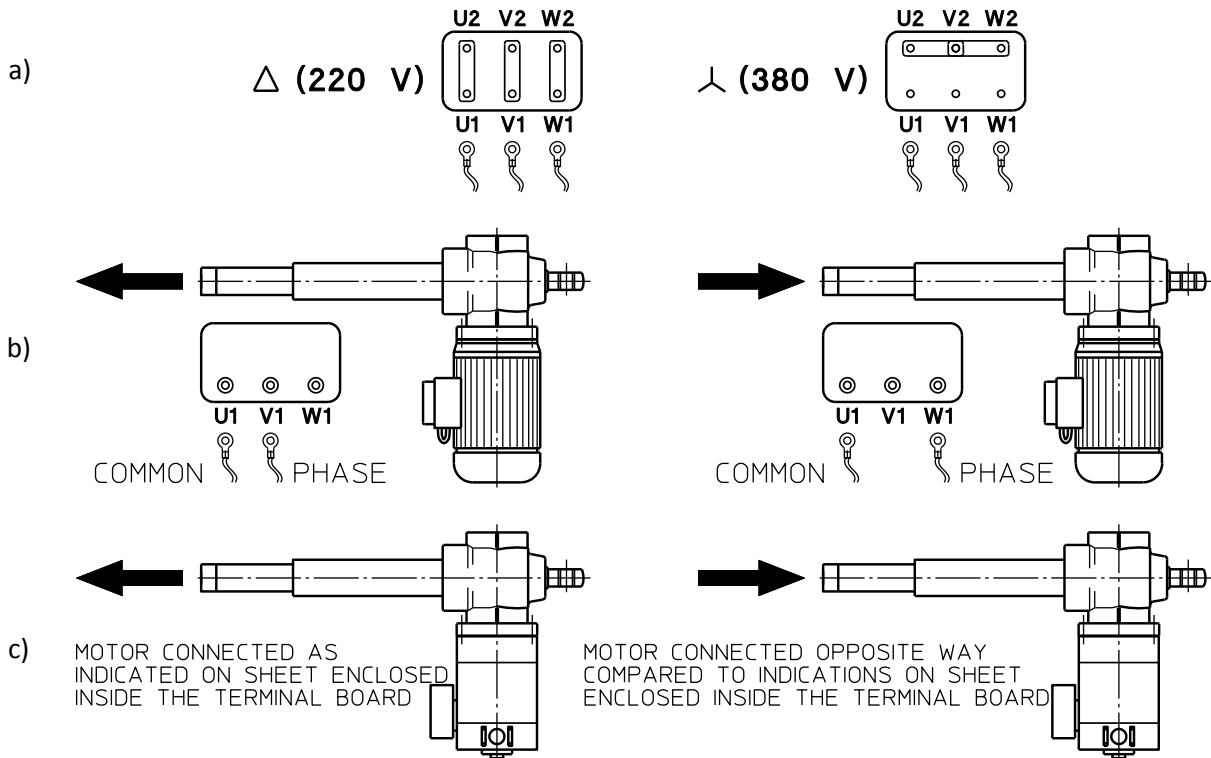

Figure 6.2 – Electric wiring diagrams to motor terminal board
(a) AC 3-phase motor; (b) AC 1-phase motor; (c) DC motor

Check if the push rod shifting direction is compatible to the indications on the control unit, by powering the electric motor on VERY BRIEFLY.

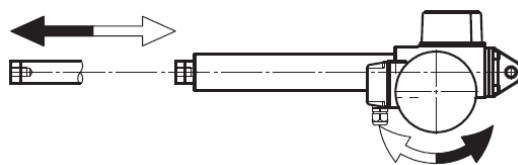

Figure 6.3 – Push rod shifting directions

If the push rod shifting directions are not compatible:

- A) ACTUATOR WITH THREE-PHASE MOTOR: invert any wire pair (U1 ↔ V1, or U1 ↔ W1, or V1 ↔ W1) into the terminal board;
- B) ACTUATOR WITH SINGLE-PHASE MOTOR: change the contact (V1 ↔ W1);
- C) ACTUATOR WITH DIRECT CURRENT MOTOR: invert contacts of the two motor supply cables.

In case of brake motor:

- the brake is NORMALLY CLOSED (NEGATIVE action). When the power supply is switched off, the brake is engaged. The brake opens only when power is supplied;
- if the brake is wired directly to the connecting pins of the terminal box, it does not require any power supply;
- if the brake is wired separately, make sure that the correct voltage is used;
- if the brake is equipped with hand release device, make sure that the brake is engaged before starting the linear actuator.

6.7 Linear actuator installation

- ⚠ THE BALL SCREW LINEAR ACTUATOR (CLB SERIES) IS NOT SELF-LOCKING. BEFORE TO APPLY ANY AXIAL LOAD ON THE PUSH ROD, LOCK THE INPUT SHAFT OR USE THE MOTOR BRAKE.
- ⚠ ALL MECHANICAL AND ELECTRICAL PROTECTION MUST BE INSTALLED AND ACTIVATED TO PREVENT DAMAGE TO PERSONS OR PROPERTY.

- Check that all plant fixing elements are well machined and cleaned, and that they fit the dimensions of the actuators fixing elements they have to be fixed to.
- If the length of the actuator have to be changed (push rod more retracted or extended) during installation, the motor speed and torque must be limited in order to avoid possible damages in case of a mechanical stop is reached.

⚠ DO NOT SET THE LENGTH OF THE ACTUATOR OVER ITS EXTREME VALUES:

- “Lc” = RETRACTED ACTUATOR
- “La” = EXTENDED ACTUATOR

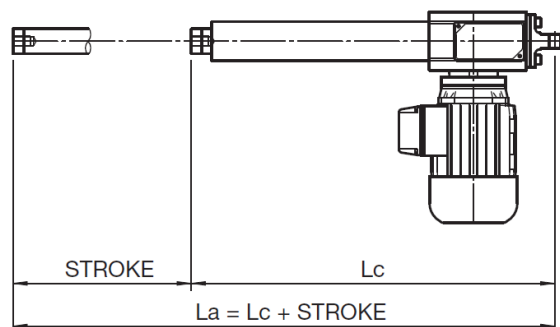

Figure 6.4 – Quote “Lc” and “La”

Dimensions “Lc” and “La” are indicated in the technical catalogue of the product and on the check sheet supplied with the actuator.

- Fit the actuator to the plant in order to have ONLY axial load applied to the actuator.
- Check the correct alignment between front and rear pins: they must be PARALLEL.
- Check the correct alignment between the actuator and the moving parts.

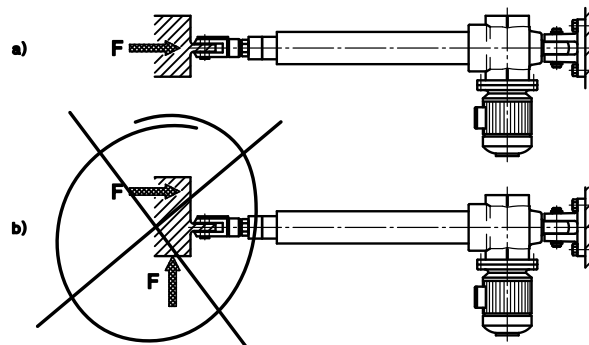
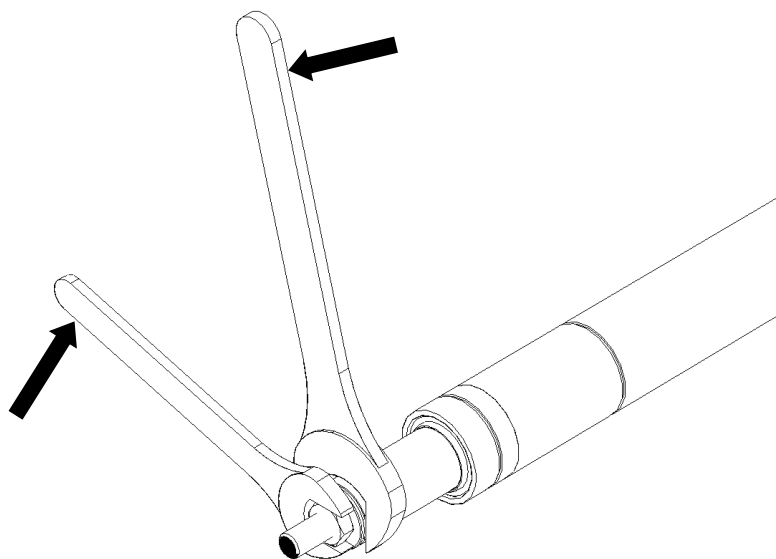

Figure 6.5 – Load on actuator: a) correct; b) not correct

⚠ RIGHT WORKING OF THE ACTUATOR AND PLANT CANNOT BE GUARANTEED IF SIDE OR NOT AXIAL LOAD ARE APPLIED TO THE ACTUATOR.

6.8 Installation of rod end fitting elements

- To install a mounting element on the rod end threaded bore (BA), use a wrench flat on the rod end to counterhold the locking torque.
- ⚠ In case of actuator equipped with AR (anti-rotation) device: DO NOT TRANSFER ANY TORQUE TO THE PISTON ROD.
- ⚠ WARNING: in case of torque transfer into the actuator with AR device, the internal mechanical components can be damaged.
- Fix the threaded element with Loctite 270.
- To unmount the element, heat the threaded area to unlock it.
- Unscrew the fitting element counterholding the torque with a wrench flat on the rod end.



7 COMMISSIONING AND USE

SERVOMECH linear actuators are supplied lubricated and ready to be used. Before to start commissioning and activation, the following checks must be carried out:

Shifting direction check

- Check if the push rod shifting direction is compatible to the indications on the control unit, by powering the electric motor on VERY BRIEFLY. If not, see Chap. 6.6.
- ⚠ For actuator without ANTI-ROTATION device (AR): TO ALLOW THE TRANSLATION OF THE ROD END, THE PUSH ROD ROTATION MUST BE REACTED BY USING EXTERNAL GUIDES.

Check of extreme working positions

- Check if the extreme dimensions of the actuator “Lc” and “La” (see Fig. 6.4) are compatible with extreme positions of the plant component that has to be moved.
- Measure the initial length of the actuator, then run the actuator GRADUALLY from the control unit, in order to reach the plant to its more distant extreme position.
- Check continuously the current actuator length during the motion.
- Repeat the same procedure for the other extreme position.

⚠ TO AVOID DAMAGES, DO NOT TRAVEL OVER THE EXTREME STROKE VALUES Lc and La!

⚠ DO NOT REACH STROKE END MECHANICAL STOP!

Commissioning

At this stage it is possible to start commissioning:

- Carry out one complete working cycle, without load, adjusting the previously set limit switch positions if necessary (see Section 6.3).
- Carry out some complete working cycles, increasing gradually the load, until full load is reached.

⚠ ONLY IN CASE ON **CLA ACTUATOR** (ACME SCREW DRIVE): DURING COMMISSIONING, DO NEVER EXCEED THE MAX ALLOWED DUTY CYCLE FOR THE LINEAR ACTUATOR: **30% OVER 10 MIN** TIME PERIOD AT 25°C ENVIRONMENT. ANY ABUSE OF SUCH DUTY CYCLE CAN CAUSE OVERHEATING AND UNINTENTIONAL PREMATURE DAMAGING!

8 LUBRICATION

SERVOMECH linear actuators CLA/CLB series are supplied lubricated, with lubricants indicated in the table below.

ACTUATOR	GEARBOX	LINEAR DRIVE	PUSH ROD GUIDE
CLA 30	Grease (NLGI 0 DIN 51818): ENI Grease MU EP 0	Grasso (NLGI 2 DIN 51818): ENI Grease SM 2 Also suitable: SHELL Gadus S2 V220D 2 (NLGI 2) MOBIL Mobilgrease XHP 222 Special (NLGI 2) FUCHS Renolit FLM 2 (NLGI 2)	(*)
CLA 40			Same as linear drive
CLA 50			
CLB 30	Grease (NLGI 0 DIN 51818): ENI Grease MU EP 0	Grease (NLGI 1 DIN 51818): LUBCON Thermoplex ALN 1001 Also suitable: FUCHS Renolit AX 2P (NLGI 2) AGIP Grease AC 1 (NLGI 1) MOBIL Mobilgrease FM 101 (NLGI 1) KLUBER Klubersynth UH1 14-151 (NLGI 1)	(*)
CLB 40			Same as linear drive
CLB 50			

Table 8.1 – Lubricants

(*) – Push rod guide bush in self-lubricating material (no lubrication required).

- ⚠ DO NOT USE LUBRICANTS DIFFERENT FROM THOSE ABOVE MENTIONED.
- ⚠ DO NOT MIX INCOMPATIBLE GREASES.
- ⚠ IF DIFFERENT LUBRICANT SHOULD BE USED, PLEASE CONTACT SERVOMECH BEFORE PROCEED.
- ⚠ IN CASE OF CUSTOM PRODUCT EXECUTION, THE LUBRICANTS COULD BE DIFFERENT FROM THE STANDARD ABOVE. TO KNOW THE TYPE OF LUBRICANT PLEASE REFER TO THE PRODUCT CHECK SHEET SUPPLIED WITH THE PRODUCT.

9 MAINTENANCE

- The gearbox is longlife lubricated and will not require any further relubrication.
- The linear drive and the push rod guide require periodic relubrication, according to Table 9.1 “Maintenance”, or at the latest after 1 year of time. Please use the lubricant indicated in Table 8.1 or equivalent.
- Every 2 months time interval: visual inspections of actuator conditions, cleaning of dirty parts of the actuator.
- In case of lubricant leakage, contact SERVOMECH.

ACTUATOR	Lead pitch [mm]	Lubrication interval [km of stroke]	Linear drive – Q.ty of lubricant		Push rod guide Q.ty of lubricant
			Q.ty for actuator stroke 100mm	Q.ty for each additional 100mm of stroke	
CLA 30	4	4	3 cm ³	2 cm ³	(*)
	8	8			
CLA 40	5	5	4 cm ³	2 cm ³	(*)
	10	10			
CLA 50	6	6	5 cm ³	3 cm ³	2 cm ³
	12	12			
CLB 30	5	50	2 cm ³	2 cm ³	(*)
	10	100			
CLB 40	6	60	3 cm ³	2 cm ³	(*)
	10	100			
CLB 50	10	100	5 cm ³	3 cm ³	2 cm ³
	20	200	4 cm ³	2 cm ³	

Table 9.1 – Maintenance

(*) – Push rod guide bush in self-lubricating material (no lubrication required).

9.1 Linear drive lubrication

⚠ WARNING! THE PLANT MUST BE STOPPED BEFORE BEGINNING ANY MAINTENANCE OPERATION.

- Before to start relubrication, put the actuator in extended position (La – see Fig. 6.4)
- Relube the linear actuator using proper grease nipples, as shown on Fig. 9.2.
- Grease nipple type: DIN71412 M6

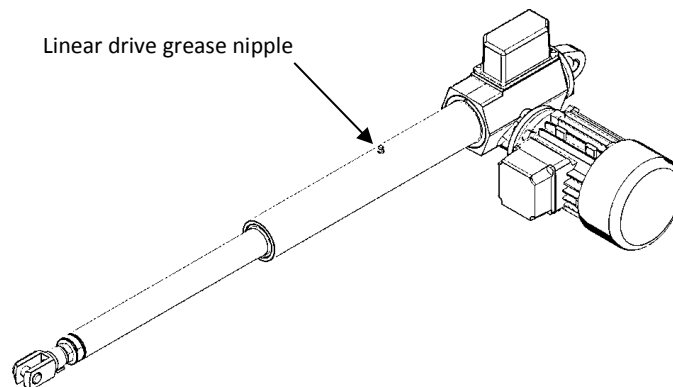

Figure 9.2 – Linear drive relubrication

- Apply the grease quantity indicated in Tab 9.1 with several partial quantities.
- Travel over the entire stroke between one lubricating operation and the next.

- ⚠ WHEN LUBRICATING THE LINEAR DRIVE, THE ACTUATOR MUST ALWAYS BE IN EXTENDED (La) POSITION. DO NOT LUBRICATE THE LINEAR SCREW DRIVE IN RETRACTED (Lc) OR INTERMEDIATE POSITIONS!
- ⚠ IN CASE OF STROKE LENGTH ≥ 500 mm, 2 GREASE NIPPLES FOR THE LINEAR DRIVE LUBRICATION ARE PLACED ON ACTUATOR. EQUALLY SPLIT THE TOTAL LUBRICANT QUANTITY (SEE TABLE 9.1 "MAINTENANCE") BETWEEN THE 2 GREASE NIPPLES.
- ⚠ FOR CLA/CLB 50 ACTUATORS: DO NOT CONFUSE THE LINEAR DRIVE GREASE NIPPLE WITH THE PUSH ROD GUIDE GREASE NIPPLE (SEE SECTION 9.2 "PUSH ROD GUIDE LUBRICATION").
- At the end of lubricating procedure, extend and retract the push rod over its entire stroke for 3 full cycles.
- If necessary, remove excess of lubricant from push rod.

9.2 Push rod guide lubrication

- ⚠ PUSH ROD GUIDE RELUBRICATION IS ONLY REQUIRED FOR ACTUATOR CLA50 E CLB50.
- ⚠ WARNING! THE PLANT MUST BE STOPPED BEFORE BEGINNING ANY MAINTENANCE OPERATION.
- Relube the push rod guide using proper grease nipples, as shown on Fig. 9.3.
- Grease nipple type: DIN71412 M6

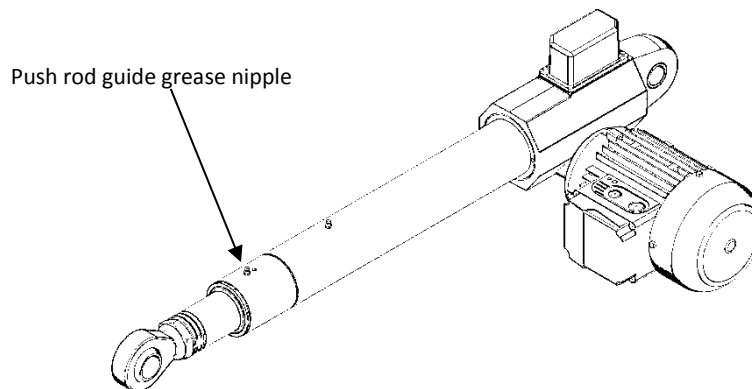

Figure 9.3 – Push rod guide grease nipple

- Apply the grease quantity indicated in Tab 9.1.
- Extend and retract the push rod over its entire stroke for 3 full cycles.
- If necessary, remove excess of lubricant from push rod.