

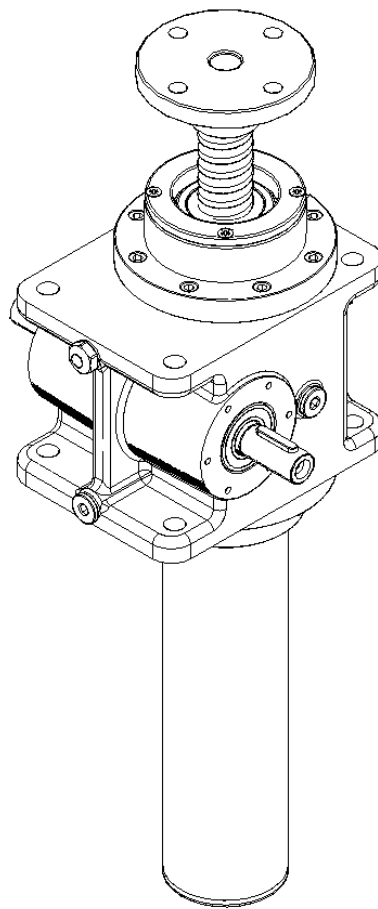

BALL SCREW JACK WITH TRAVELLING SCREW

MA BS Mod.A Series

Installation, operation and maintenance manual



Publication: 01.BS-ModA.E - Rev. 00 Date (M/Y) 05/19

Servomech S.p.A. Via M. Calari, 1 - 40011 Anzola dell'Emilia (BO) - ITALY

Ph: + 39 051 6501711 Fax: + 39 051 734574

www.servomech.com info@servomech.com



Read this manual before installing, operating or maintaining this screw jack. Failure to follow safety precautions and instructions could cause screw jack failure and result in serious injury, death or property damage.

This manual provides important information on how to work with the screw jack safely and efficiently. The manual is part of the device, must always be kept in the device's direct proximity and should be available for personnel to read at any time. Failure to comply with the installation, use and maintenance instructions indicated in this manual will result in immediate termination of the warranty conditions of the screw jack and completely relieve Servomech S.p.A. from any liability for damage caused to persons and / or property.

Servomech S.p.A. it does not assume direct or indirect responsibility for an improper use of the screw jack, not respecting the performances of the screw jack declared in the catalogs.

The manufacturer will not be liable for damage to the screw jack or the equipment into which the screw jack has been installed resulting from:

- disregarding this manual
- unintended use
- employment of untrained personnel
- unauthorized conversions
- technical modifications
- manipulation or removal of the screws on the device
- use of unapproved spare parts

The aforementioned conditions are therefore not contemplated and entail the immediate termination of the guarantee and the immediate decay of any responsibility on the part of Servomech S.p.A.

Servomech S.p.A. reserves the right to make changes to the screw jack and this manual without giving any notice.

BALL SCREW JACK WITH TRAVELLING SCREW
MA BS Mod.A Series
Installation, operation and maintenance manual

Contents

1	MODELS COVERED BY THIS DOCUMENT	4
2	IDENTIFICATION OF THE MANUFACTURER AND THE PRODUCT	4
2.1	Identification of the manufacturer.....	4
2.2	Description of the product	4
2.3	Identification of the product	5
3	TRASPORT AND HANDLING	6
4	USE RESTRICTION	7
4.1	Intended use.....	7
4.1.1	Use restrictions.....	7
4.1.2	Standard operating conditions.....	8
4.2	Personnel requirements / Qualifications	8
5	STORAGE.....	8
6	INSTALLATION	9
6.1	Safety warnings	9
6.2	FCP inductive proximity stroke limit switches.....	10
6.2.1	Adjustable FCP proximity stroke limit switches	11
6.3	FCM magnetic stroke limit switches.....	12
6.4	Rotary encoder ENC.4	14
6.5	Rotary encoder EH53.....	14
6.6	Electric motor installation	15
6.7	Screw jack installation	16
6.8	Installation of fitting elements on threaded end	17
7	COMMISSIONING AND USE	18
8	LUBRICATION	19
9	MAINTENANCE	20
9.1	Ball screw lubrication	21
9.2	Gearbox lubrication.....	21
9.2.1	Lubricant refill.....	21
9.2.2	Lubricant replacement	21
9.3	Anti-rotation device lubrication	22

1 MODELS COVERED BY THIS DOCUMENT

The present manual is referred to following products:

Ball screw jack with travelling screw: MA 5 BS Mod.A – MA 10 BS Mod.A – MA 25 BS Mod.A –
MA 50 BS Mod.A – MA 100 BS Mod.A – MA 150 BS Mod.A – MA 200 BS Mod.A – MA 350 BS Mod.A

2 IDENTIFICATION OF THE MANUFACTURER AND THE PRODUCT

2.1 Identification of the manufacturer

SERVOMECH S.p.A. S.U.

Via Monaldo Calari, 1
40011 Anzola dell'Emilia (BO)
ITALY
Ph. +39 051 6501 711
Fax. +39 051 7345 74
Website: www.servomech.com
e-mail: info@servomech.com

2.2 Description of the product

For all the technical characteristics of the product (performance, features, dimensions) refer to the technical catalog.

Main components of the screw jack:

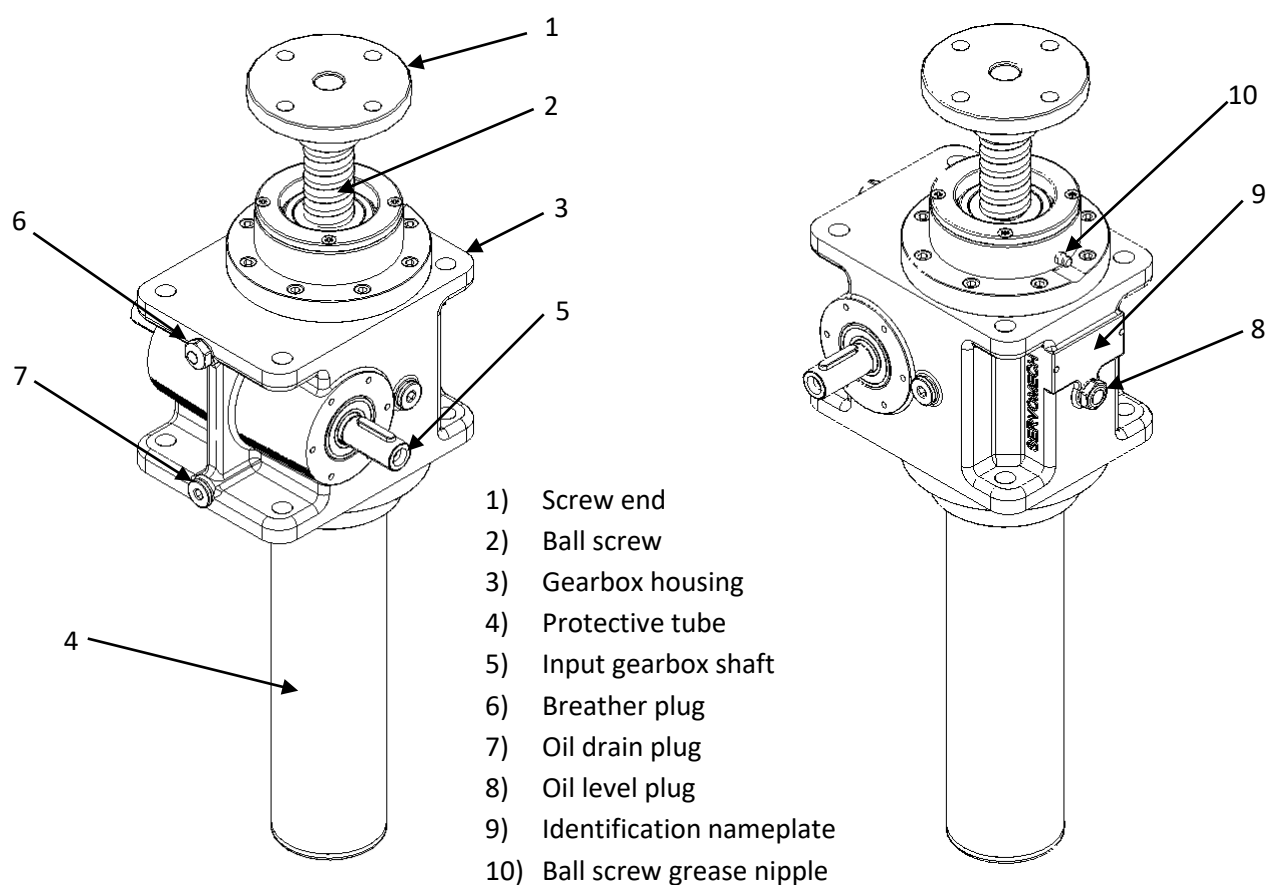

Figure 2.1 – Main components of the screw jack

2.3 Identification of the product

Every SERVOMECH screw jack is provided with a nameplate, as shown below, which allows the product identification and gives technical information about the product.

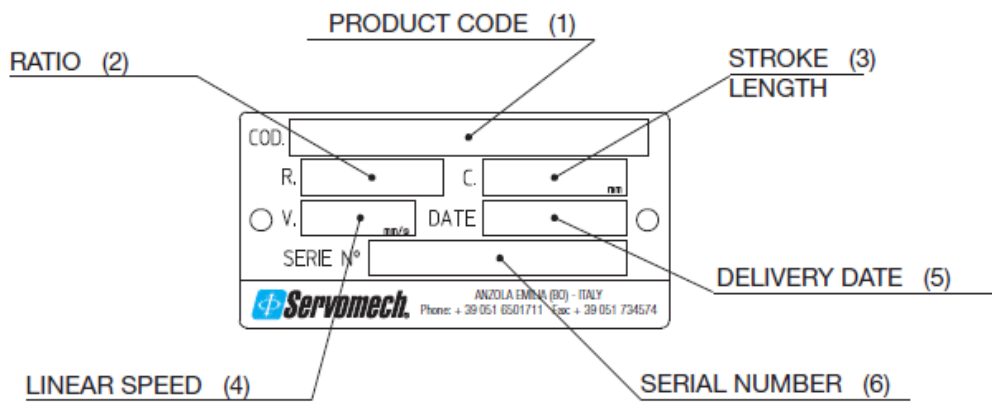

Figure 2.2 – Identification nameplate

- 1) **Product code**: is an alphanumeric code stating the type, size, ratio, version and stroke end switches of the screw jack;
- 2) **Ratio**: is the ratio of the input drive;
- 3) **Stroke length**: is the stroke length in millimetres achievable by the screw jack;
- 4) **Linear speed**: is the linear speed expressed in mm/s when the screw jack is provided with electric motor; for a screw jack without motor, this field is blank;
- 5) **Delivery date**: is the week/year of assembly (example: 30/13 = week 30 / year 2013) which usually coincides with the delivery date; this date is considered as reference for the warranty period;
- 6) **Serial number**: is the identification number of the screw jack which identifies the exact design of the product even after a long time; the serial number is the essential reference for spare part orders.

3 TRASPORT AND HANDLING

- ⚠ Screw jacks with mounted ball screw and all accessories can be often difficult to handle because of their overall dimensions. Therefore, it is recommended to pay attention and care during the handling and transport of screw jack not to damage mechanical parts and / or accessories and to prevent risks for the personnel in charge of this activity.
- The packaging must be lifted and moved with care and in a safe way.
- Use only safety-inspected and suitable load hoisting equipment.
- For lifting and transporting the screw jack with protective tube, the ball screw must be in retracted position.
- For lifting and transporting the screw jack without protective tube, the ball screw must be in half stroke position.
- When transporting the product with attached motor, always provide support for the motor, or remove the motor before transporting the product.
- Lift the screw jack from the holes on the housing and from the outer tube (if present), in the area closed to the housing.
- Make sure that the weight of the screw jack is well balanced.
- DO NOT lift the screw jack from the ball screw or from the tube end.
- DO NOT lift the screw jack from the motor.
- Prevent the screw jack from swinging during lifting operations.
- ⚠ Ball screw jack are NOT self-locking. Never lift the screw jack upright from the ball screw as the screw jack could be back driven by its own weight.

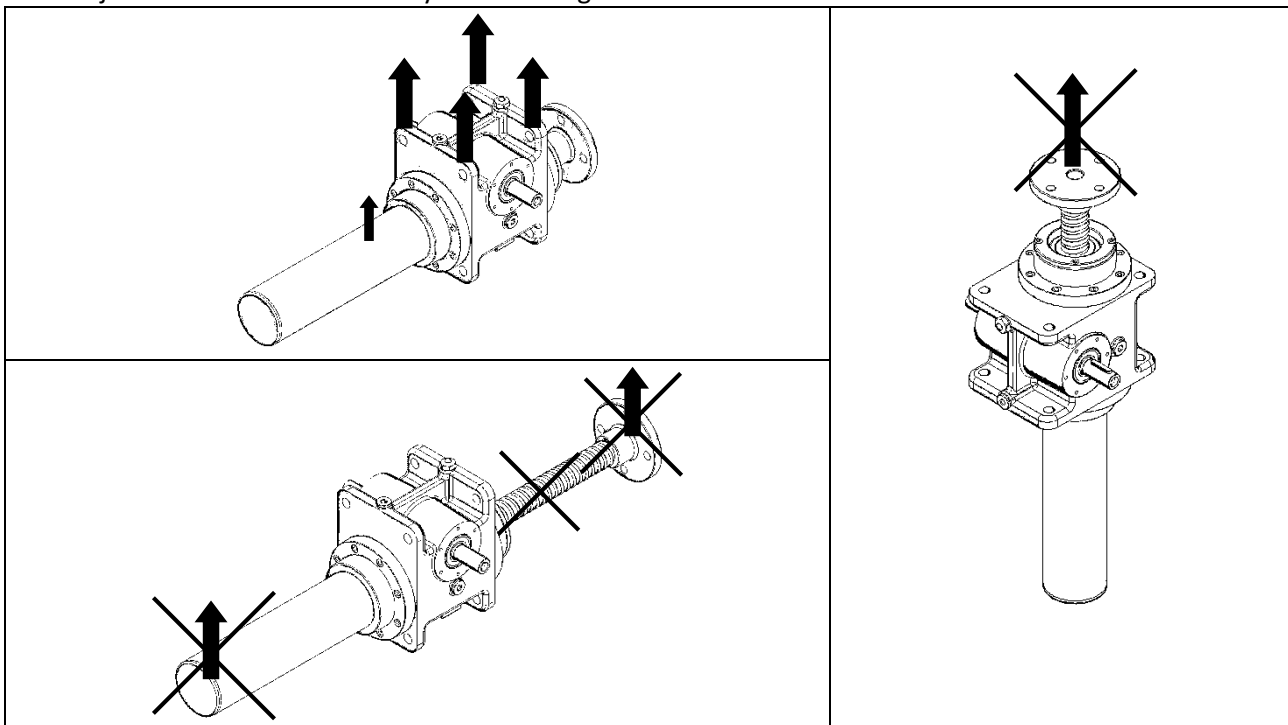

Figure 3.1 – Transport and handling

- Before hoisting the screw jack, check the weight on the following table:

	MA 5 BS	MA 10 BS	MA 25 BS	MA 50 BS	MA 100 BS	MA 150 BS	MA 200 BS	MA 350 BS
Mass of the screw jack w/o ball screw [kg]	2.2	4.3	13	26	48	48	75	145
Mass for each 100mm ball screw [kg]	0.2	0.4	0.6	0.9	1.4	2.3	3.7	6.2

In case of doubt, consult SERVOMECH S.p.A. to get the appropriate information and prevent any kind of damage!

4 USE RESTRICTION

The information contained in this chapter provides important prescriptions for operating safely during all phases of the product's life.

Not knowing or not complying with these provisions can generate dangerous situations that could cause damage to equipment and risks for the safety of persons.

4.1 *Intended use*

Screw jacks are used to perform very different functions within machines. It is the responsibility of the machine builder to design the application in compliance with the laws in force in the specific sector and in the field of safety, in compliance with the requirements provided in the product catalog and in this manual.

- ⚠ SCREW JACKS ARE ELECTRIC AXIS, WHATEVER DRIVER OR CONTROL WILL BE USED: THE SELECTION OF THE PRODUCT AS STROKE, SPEED, TYPE OF LIMIT SWITCHES, MOTOR AND BRAKE, MUST BE DONE ACCORDING TO THE BEHAVIOR EXPECTED, IN FUNCTION OF THE TYPE OF CONTROL CHOSEN AND THE STATIC AND DYNAMIC BEHAVIOR OF THE SYSTEM IN WHICH THE SCREW JACK IS PLACED!

The screw jacks have been designed and built to operate mobile parts of various types, shapes and construction, in the ways and within the limits set out in the descriptions and tables of the technical data in the catalog and in this user manual.

The screw jacks are designed to work with a purely axial applied load.

They must be subjected to the loading and speed conditions specified in the catalog.

Modification of parts of the screw jack or replacement of components with different and non-original parts is not permitted. The replacement of components with original spare parts is carried out only by Servomech S.p.A.

Any different use is to be considered improper and therefore potentially dangerous for the safety of the operators, as well as such as to void the contractual guarantee.

In the event of particular processing requirements, we recommend consulting our sales department.

Every modification must be authorized by Servomech S.p.A. with written documents.

- ⚠ ANY OTHER USE OUTSIDE THAT THAT JUST DESCRIBED IS NOT PERMITTED BY SERVOMECH S.p.A.

4.1.1 Use restrictions

Screw jacks can not be used for unforeseen applications.

Any utilization of this device beyond its intended purpose may lead to potentially hazardous situations.

Therefore:

- Strictly adhere to all safety precautions and instructions in this operating manual.
- Do not allow this device to be subjected to weather conditions, strong UV rays, corrosive or explosive air media as well as other aggressive media (*).
- Do not modify, retool or change the structural design or individual components of the screw jack.
- Never use the device outside of the technical application and operational limits.

- ⚠ THE USE OF THE SCREW JACK IN DIFFERENT CONDITIONS THAN JUST DESCRIBED MUST BE PREVIOUSLY DECLARED AND AGREED WITH SERVOMECH, SINCE A SPECIAL EQUIPMENT OF THE PRODUCT MUST BE PROVIDED.

4.1.2 Standard operating conditions

The screw jacks must be used in an environment whose conditions comply with the provisions of Servomech S.p.A. The works necessary for obtaining and maintaining that conditions are in charge of the owner and, where applicable, are in charge of the end user.

The screw jack must be installed and used indoor only, in dry area with environmental conditions as specified below:

- Temperature range +0°C ÷ +40°C
- Relative atmospheric humidity 5% ÷ 85%
- No build up of condensation

⚠ THE USE OF THE SCREW JACK IN DIFFERENT CONDITIONS THAN JUST DESCRIBED MUST BE PREVIOUSLY DECLARED AND AGREED WITH SERVOMECH, SINCE A SPECIAL EQUIPMENT OF THE PRODUCT MUST BE PROVIDED.

4.2 Personnel requirements / Qualifications

This manual must be made available to the personnel in charge of installation, start up and use of the screw jack. It is the responsibility of the machine builder:

- use personnel with the necessary qualifications for the installation and commissioning of the screw jack;
- periodically check the qualification of the assigned personnel;
- check that the personnel in charge are aware of the contents of this manual.

5 STORAGE

- Do not store outside.
- Storage should be dry and dust-free.
- Keep away from any aggressive media.
- Protect from UV radiation.
- Avoid mechanical vibrations.
- Storage temperature: 0 to +50 °C.
- Relative atmospheric humidity: max. 95% (no build up of condensation).
- To store longer than 6 months, take care of moving the input shafts to prevent damages to sealings.
- Also check that all unpainted parts are adequately protected (oiled and /or greased) to prevent oxidation.

6 INSTALLATION

The operations described in the paragraphs of this chapter provide both electrical and mechanical connections of the screw jack, as well as the execution of test motions at reduced speed and motor torque or with small displacement steps.

6.1 Safety warnings

- ⚠ MOTORS CANNOT BE CONNECTED DIRECTLY TO THE ELECTRICITY GRID. A PROPER CIRCUITS AND DEVICES FOR MOVEMENT MANAGEMENT ON BOTH DIRECTIONS IS REQUIRED. STROKE END LIMIT SWITCHES (MICROSWITCHES OR SENSORS) MUST BE CONTROLLED TO BE SURE THE LINEAR MOVEMENT OF THE SCREW JACK (DUE TO THE OPERATION OF THE MOTOR OR TO THE INERTIA OF THE MOVING PARTS) STOPS BEFORE TO REACH THE MECHANICAL STROKE END LIMITS. IN CASE THIS HAPPENS, THE SCREW JACK CAN BE LOCKED AND THE INTERNAL COMPONENTS CAN BE DAMAGED.
- ⚠ WHEN THE MOTORS MUST BE POWERED BY A CONVERTER (ELECTRIC DRIVE), THIS MUST BE CHOSEN BY QUALIFIED PERSONNEL.
- ⚠ IN CASE THERE ARE INVOLVED ELECTRONIC DRIVE AND CONTROL DEVICES ON THE SCREW JACK MOVING CONTROL, REFER TO MANUALS FOR ALL THE NECESSARY INFORMATION AND CORRECT INSTALLATION AND MAINTENANCE OF THE PRODUCT.
- ⚠ BEFORE TO PROCEED TO THE ELECTRIC CONNECTION, MAKE SURE THE SUPPLY VOLTAGE IS TURNED OFF.
- ⚠ BEFORE TO TURN-ON THE MOTOR, MAKE SURE THE ELECTRIC CONNECTIONS ARE TIGHTENED AND STABLE.
- ⚠ CHECK POWER SUPPLY CABLES NOT TO BE DAMAGED DURING THE COMMISSIONING. POWER SUPPLY CABLES MUST BE OUT OF HEAT SOURCES AND MOVING ORGANS.
- ⚠ DURING FUNCTIONING ARE PRODUCED MAGNETIC, ELECTRIC AND ELECTROMAGNETIC FIELDS. THIS MAY BE DANGEROUS FOR PEOPLE THAT USE CARDIAC STIMULATOR (PACEMAKER), IF NOT SUFFICIENT DISTANCE.
- ⚠ DO NOT DISCONNECT ANY CONNECTION DURING OPERATION OR IN PRESENCE OF SUPPLY VOLTAGE.
- ⚠ BEFORE TO TURN-ON THE MOTOR, MAKE SURE THE MECHANICAL CONNECTIONS OF THE SCREW JACK REMAIN TIGHTENED AND STABLE, ALSO DURING THE OPERATION.
- ⚠ DURING THE COMMISSIONING, UNEXPECTED MOVEMENT OF THE MOTOR MAY BE CAUSED BY:
 - WIRING ERRORS
 - MOUNTING ERRORS
 - DAMAGES ON POWER SUPPLY CABLES
 - HARDWARE OR SOFTWARE ERRORS
 - DRIVER PARAMETERS ERRORS
 - OPERATION IN CONDITIONS OUTSIDE THE SPECIFICATIONS PROVIDED BY THE CATALOG AND THIS MANUAL
- ⚠ MAKE SURE THE SAFETY PROTECTION OF THE MACHINE (MECHANICAL AND ELECTRICAL) ARE ACTIVE.
- ⚠ DURING OPERATION, TEMPERATURE OF THE EXTERNAL SURFACE OF MOTORS OR SCREW JACKS CAN REACH HIGH TEMPERATURES. HOT SURFACES ON SCREW JACK CAN CAUSE BURNS AND SHOULD NOT BE TOUCHED.

6.2 FCP inductive proximity stroke limit switches

The INDUCTIVE PROXIMITY STROKE LIMIT SWITCHES allow the screw jack to stop before reaching the internal mechanical stop avoiding damage. If intermediate sensors are present, they can be used to fix intermediate positions along the screw jack stroke length. The inductive proximity stroke end switches are fixed directly on the outer tube in the required position and are activated by a metallic ring fixed on the ball screw end.

- The switches position is not adjustable.
- The positions of the two limit switches are the extreme travel positions Lc and La (see Fig. 6.7).
- FC 1 – sensor for RETRACTED SCREW JACK Lc position
- FC 2 – sensor for EXTENDED SCREW JACK La position

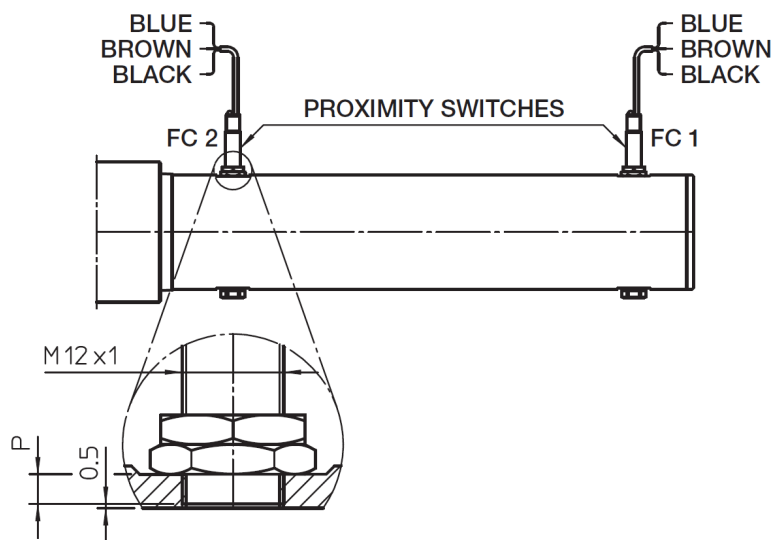

Figure 6.1 – FCP inductive proximity stroke limit switches

	Dimension P [mm]							
	MA 5 BS	MA 10 BS	MA 25 BS	MA 50 BS	MA 100 BS	MA 150 BS	MA 200 BS	MA 350 BS
T+FCP	3.5	3.5	3.5	3.5	3.5	3.5	3.5	3.5
T+AR+FCP	3.5	3.5	3.5	3.5	6	6	8.5	13.5
TG+FCP	3.5	3.5	3.5	3.5	8.5	8.5	8.5	8.5
TG+AR+FCP	3.5	3.5	3.5	3.5	6	6	8.5	13.5

- Proximity switches are supplied already mounted on the screw jack and set to the correct sensing distance.
- ⚠ DO NOT CHANGE THE SENSING DISTANCE OF PROXIMITY SWITCHES BY MOVING THE TWO NUTS FIXED ON THE SENSOR.
- In case it is necessary to restore the correct sensing distance position, please refer to Fig. 6.1.
- In case the screw jack is not stopped after the sensor activation, when the metal ring moves away, the sensor restores the original state (becomes deactivated).
- In case the limit switches are used to stop the screw jack, we recommend to provide an electric connection in order to latch the signal and to prevent the screw jack from moving again in the same direction.
- ⚠ DO NOT TRAVEL OVER THE STROKE LIMIT SWITCHES POSITIONS, AVOIDING TO REACH MECHANICAL STOP AND PREVENTING DAMAGE TO THE INTERNAL COMPONENTS OF THE SCREW JACK

6.2.1 Adjustable FCP proximity stroke limit switches

- The sensor position along the tube is adjustable in the defined range.
 - Proximity switches are supplied already mounted on the screw jack and set to the correct sensing distance.
 - The two nuts (nut and locknut) to adjust the sensing distance are locked with Loctite 270.
 - The extreme positions of the two limit switches on the slide are the extreme travel positions Lc and La (see Fig. 6.7)
 - To adjust the position of the sensor along the slide (see Fig. 6.2): unscrew the single nut, move the sensor to the required position, then screw the nut to fix it in position.
- ⚠ DO NOT CHANGE THE SENSING DISTANCE OF PROXIMITY SWITCHES BY MOVING THE TWO NUTS (NUT AND LOCKNUT) FIXED ON THE SENSOR.
- In case it is necessary to restore the correct sensing distance position “P” from the metallic ring (see Fig. 6.2): unscrew the two preloaded nuts, set the correct sensing distance from the metallic ring, screw the two nuts in position fixing them with Loctite 270.

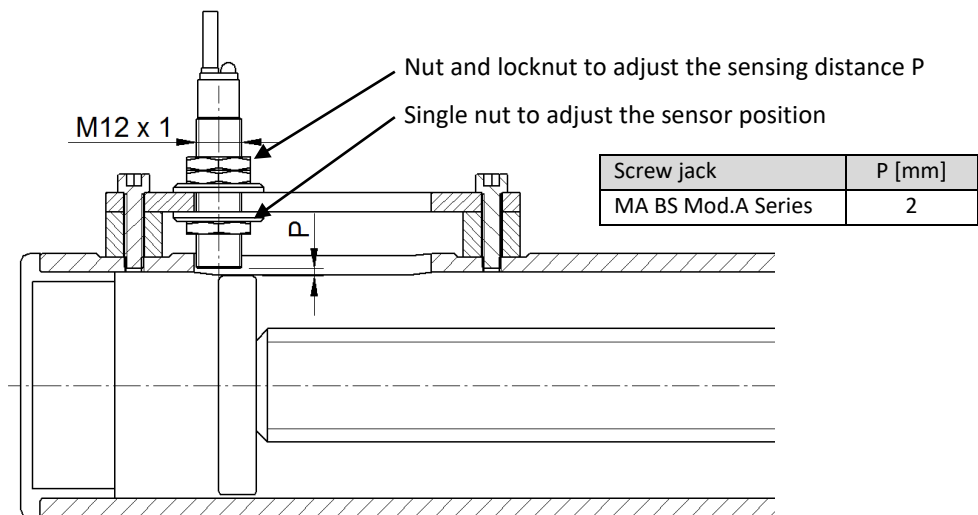
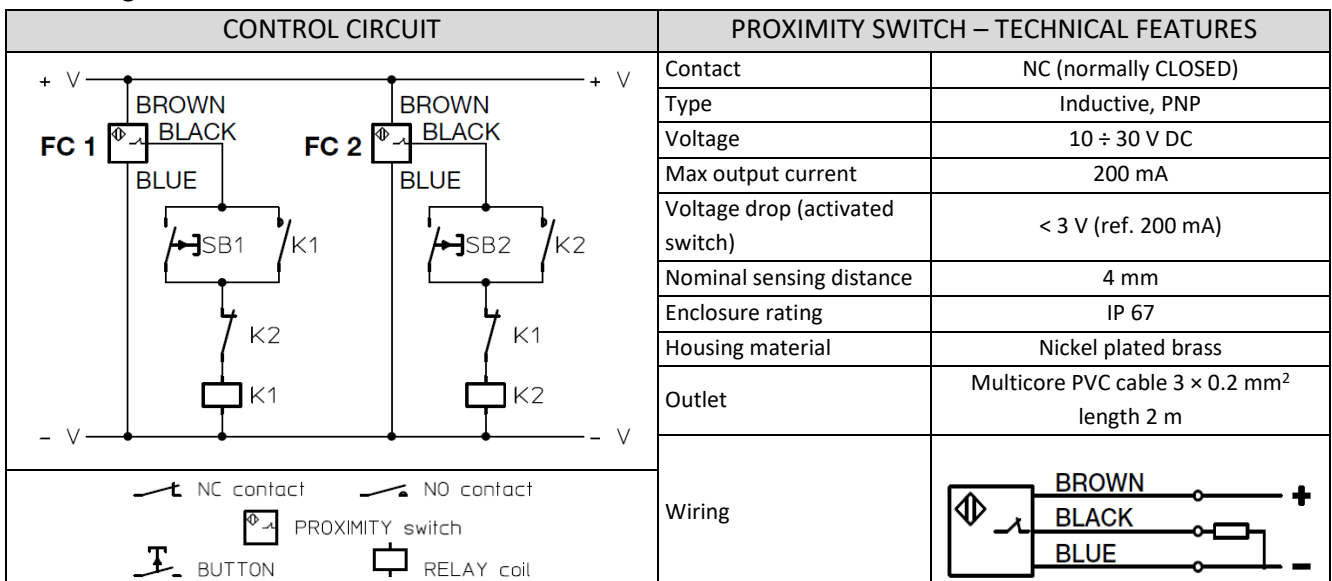

Figure 6.2 – adjustable FCP proximity limit switches

The PROXIMITY STROKE LIMIT SWITCHES must be connected to the electric control circuit as shown in the following WIRING DIAGRAM:



6.3 FCM magnetic stroke limit switches

The magnetic stroke end switches FCM allow to limit the screw jack stroke length avoiding to reach the extreme positions (mechanical stop) and preventing damage. Using more switches it is also possible to set intermediate positions along the screw jack stroke length. Magnetic limit switches are sensors with reed contact and are fitted with a clamp in the protective tube. They are activated by the magnetic field generated by a magnetic ring fitted on the travelling ball screw end.

- ⚠ The magnetic reed switches can work only if connected to a control circuit to activate electric relay.
- ⚠ DO NOT connect the reed switches in series between the power supply and the electric motor.
- Magnetic limit switches are available only for MA 5 BS, MA 10 BS, MA 25 BS screw jacks.
- The sensors are activated independently of their angular position on the tube.
- When using more contact reeds for intermediate positions, it shall be considered that the same reed switch can give the signal in 2 different positions, depending on the screw jack motion which can be retracting or extending.

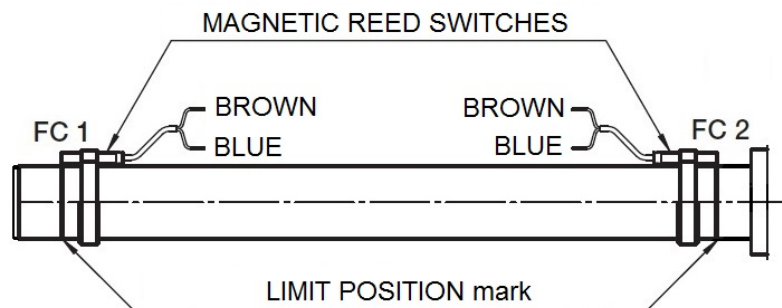

Figure 6.3 – FCM magnetic stroke limit switches

FCM magnetic limit switches are supplied already fixed on extreme stroke positions L_c and L_a (see Fig. 6.7):

- RETRACTED SCREW JACK (L_c) position: FC 1 reed switch fixed on proper limit marked on the protective tube.
- EXTENDED ACTUATOR (L_a) position: FC 2 reed switch fixed on proper limit marked on the protective tube.

The position of the reed switches can be adjusted by changing the fixing clamp position on the tube:

- Release the screw on the fixing clamp (do not release the fixing screw of the reed sensor)
- Move the fixing clamp on the tube to the desired position (do not exceed the maximum range L_c ... L_a)
- Fix the screw of the clamp.

- In case the screw jack is not stopped after the sensor activation, without magnetic field the sensor restores the original state.

- ⚠ In case the limit switches are used to stop the screw jack, we recommend to provide an electric connection in order to latch the signal and prevent the screw jack from moving again in the same direction.
- ⚠ DO NOT SET THE MAGNETIC SWITCH POSITION OVER THE LIMIT MARK ON THE TUBE.
- ⚠ DO NOT TRAVEL OVER THE STROKE LIMIT SWITCHES POSITIONS, AVOIDING TO REACH MECHANICAL STOP AND PREVENTING DAMAGE TO THE INTERNAL COMPONENTS OF THE SCREW JACK.

The MAGNETIC LIMIT SWITCHES must be connected to the electric control circuit as shown in the following WIRING DIAGRAM:

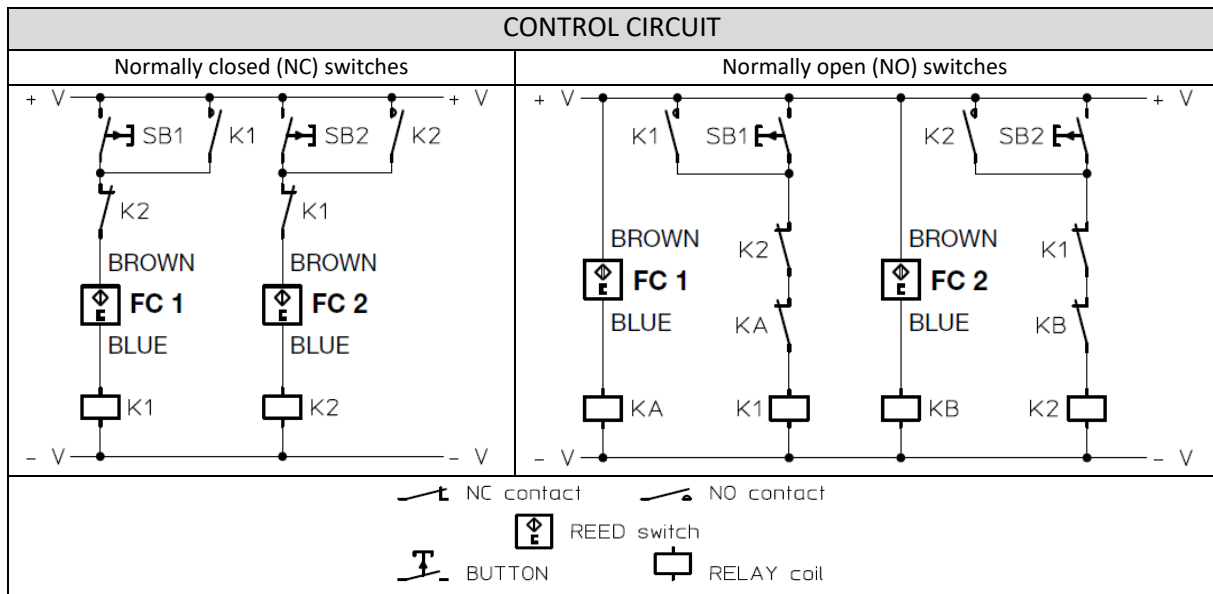

REED SWITCHES – TECHNICAL FEATURES		
Contact	NC	NO
Switching output	Reed	
Supply voltage	5 ÷ 120 V AC/DC ⁽¹⁾	5 ÷ 230 V AC/DC ⁽²⁾
Voltage drop	≤ 0.35 V	
Continuous current	≤ 100 mA (AC)	
Switching capacity	≤ 6 W	
Protection class	II	
Enclosure rating	IP 65	
Sensor housing material	Plastic	
Clamp material	Stainless steel, Zinc cast	
Outlet	Multicore PVC cable 2 × 0.12 mm ² length 2 m	
Wiring	 BN = brown BU = blue	

6.4 Rotary encoder ENC.4

Encoder ENC.4 – TECHNICAL FEATURES	
Transducer type	Hall-effect encoder, incremental, bi-directional
Resolution	4 pulses per revolution
Output	PUSH-PULL 2 channels (A and B, phase difference 90°)
Supply voltage	8 ÷ 32 V DC
Max commutable current I _{OUT}	100 mA
Max output voltage drop	with load connected to 0 and I _{OUT} = 100 mA: 4.6 V with load connected to + V and I _{OUT} = 100 mA: 2 V
Protection	against short circuit against input polarity inversion against any incorrect output connection
Cable length	1.3 m
Enclosure rating	IP 55

The rotary encoder ENC.4 must be connected to the electric control circuit as shown in the following WIRING DIAGRAM:

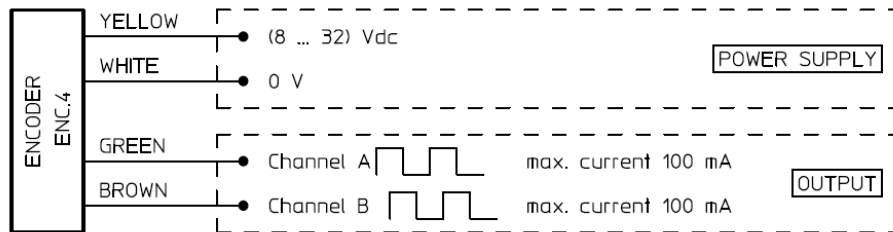

6.5 Rotary encoder EH53

Encoder EH53– TECHNICAL FEATURES	
Transducer type	Optical encoder, incremental, bi-directional
Resolution	100 or 500 pulses per revolution
Output	PUSH-PULL 2 channels (A and B, phase difference 90°) channel ZERO
Input voltage	5 ÷ 24 V DC
No-load current	100 mA
Max commutable current	50 mA
Cable length	0.5 m
Enclosure rating	IP 54

The rotary encoder ENC.4 must be connected to the electric control circuit as shown in the following WIRING DIAGRAM:

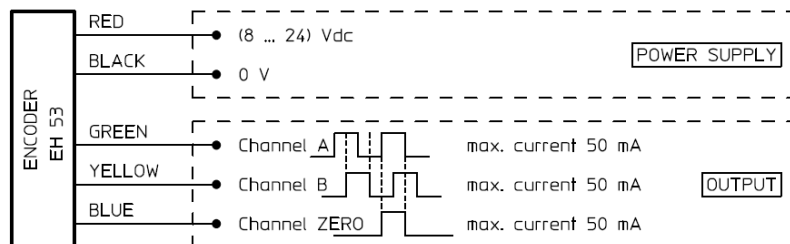

6.6 Electric motor installation

Connect the motor to the power unit of the plant or to the driver according to the following wiring diagrams.

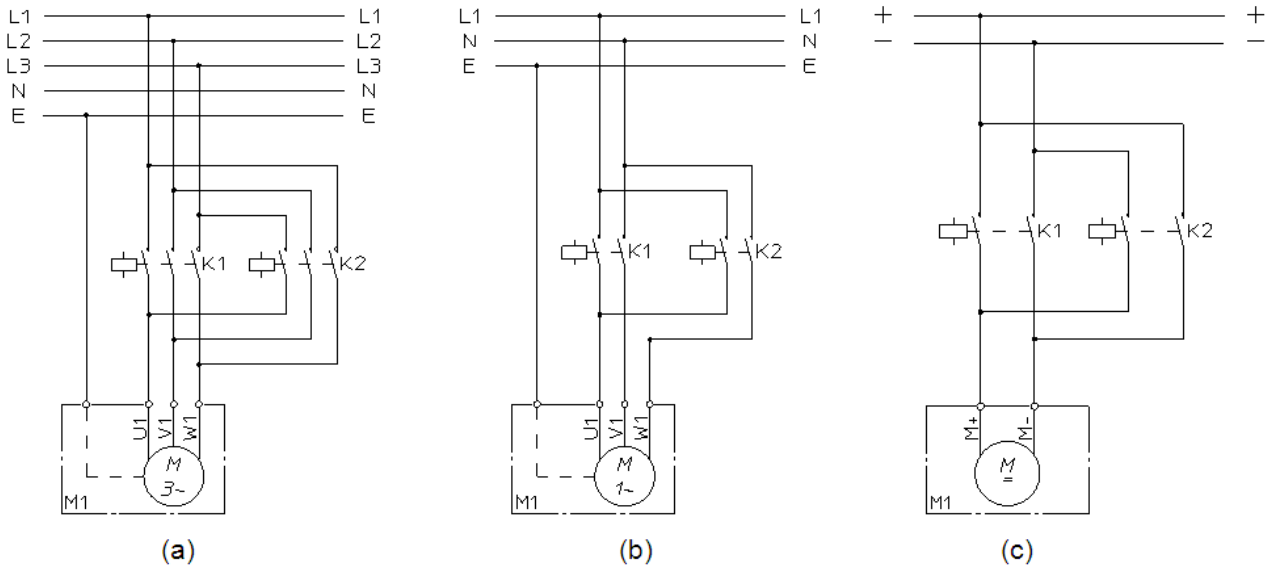

Figure 6.4 – Electric wiring diagrams to power supply
(a) AC 3-phase motor; (b) AC 1-phase motor; (c) DC motor

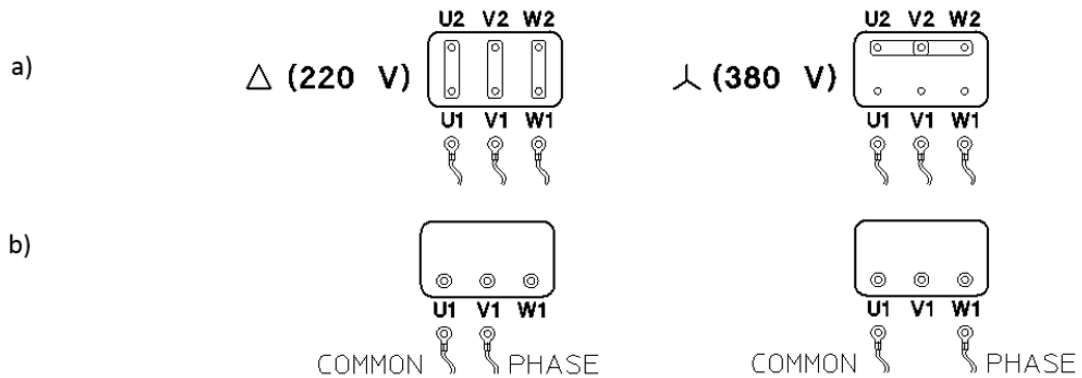

Figure 6.5 – Electric wiring diagrams to motor terminal board
(a) AC 3-phase motor; (b) AC 1-phase motor;

After electric motor installation, check if the screw jack shifting direction is compatible to the indications on the control unit, by powering the electric motor on VERY BRIEFLY.

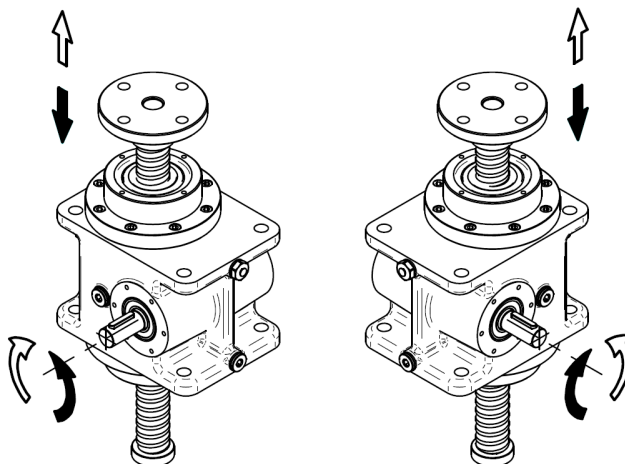

Figure 6.6 –Screw jack shifting directions

If the ball screw shifting directions are not compatible:

- A) THREE-PHASE MOTOR: invert any wire pair (U1 ↔ V1, or U1 ↔ W1, or V1 ↔ W1) into the terminal board;
- B) SINGLE-PHASE MOTOR: change the contact (V1 ↔ W1);
- C) DIRECT CURRENT MOTOR: invert contacts of the two motor supply cables.

In case of brake motor:

- the brake is NORMALLY CLOSED (NEGATIVE action). When the power supply is switched off, the brake is engaged. The brake opens only when power is supplied;
- if the brake is wired directly to the connecting pins of the terminal box, it does not require any power supply;
- if the brake is wired separately, make sure that the correct voltage is used;
- if the brake is equipped with hand release device, make sure that the brake is engaged before starting the screw jack.

6.7 Screw jack installation

- ⚠ BALL SCREW JACK ARE NOT SELF-LOCKING. BEFORE TO APPLY ANY AXIAL LOAD ON THE BALL SCREW, LOCK THE INPUT SHAFT OR USE THE MOTOR BRAKE.
- ⚠ ALL MECHANICAL AND ELECTRICAL PROTECTION MUST BE INSTALLED AND ACTIVATED TO PREVENT DAMAGE TO PERSONS OR PROPERTY.

- Check that all plant fixing elements are well machined and cleaned, and that they fit the dimensions of the screw jack fixing elements they have to be fixed to.
- If the length of the screw jack have to be changed (ball screw more retracted or extended) during installation, rotate the input shaft in proper direction (see Fig. 6.6).
- For screw jacks with electric motor: power the motor with limited speed and torque values, in order to avoid possible damages in case of a mechanical stop is reached.
- In case of screw jack without anti-rotation device (AR), it is possible to manually screw/unscrew the ball screw to change the length of the screw jack.
- In case of screw jack with bellow protection (B): DO NOT TWIST THE BELLOW.
- The gearbox is oil lubricated. To avoid leakage during transport, the BREATHER of the housing is replaced by a plug. The breather is supplied unmounted, with the screw jack. AFTER INSTALLATION, PLEASE MOUNT THE BREATHER IN THE PROPER HOLE POSITION, AS SHOWN IN FIG 2.1.

⚠ THE BREATHER HOLE POSITION IS INDICATED BY A MARKER.

⚠ THE BREATHER MUST ALWAYS BE IN UPPER POSITION.

The installation of many screw jacks for SYNCHRONIZED lifting movement requires particular attention on two different factors:

- alignment of load support points (travelling ball screw ends);
- use of connecting shafts and couplings with high torsional stiffness, to assure a perfect synchronism of all lifting points.

⚠ DO NOT SET THE LENGTH OF THE SCREW JACK OVER ITS EXTREME VALUES:

- “Lc” = retracted screw jack length
- “La” = extended screw jack length

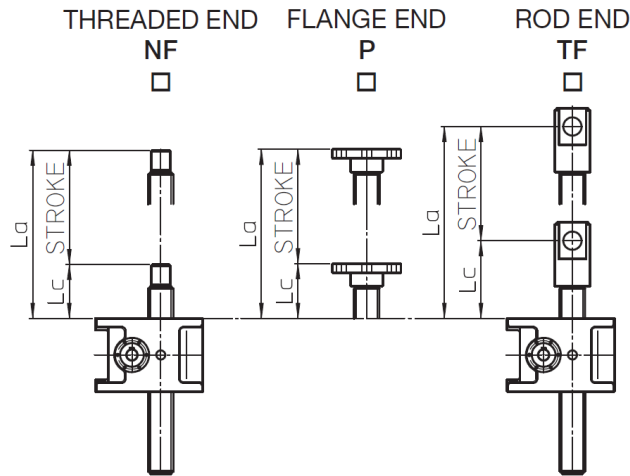

Figure 6.7 – “Lc” and “La” dimensions

Dimensions “Lc” and “La” are indicated on the check sheet supplied with the screw jack.

- Fit the screw jack to the plant in order to have ONLY AXIAL LOAD applied to the ball screw.
- Check the axis of the ball screw and the screw jack fixing surface are perpendicular.
- Check the supporting surfaces of the screw jack and the load are parallel.
- In case of screw jack with TRUNNION MOUNT (SC): the front and rear pin must be parallel.

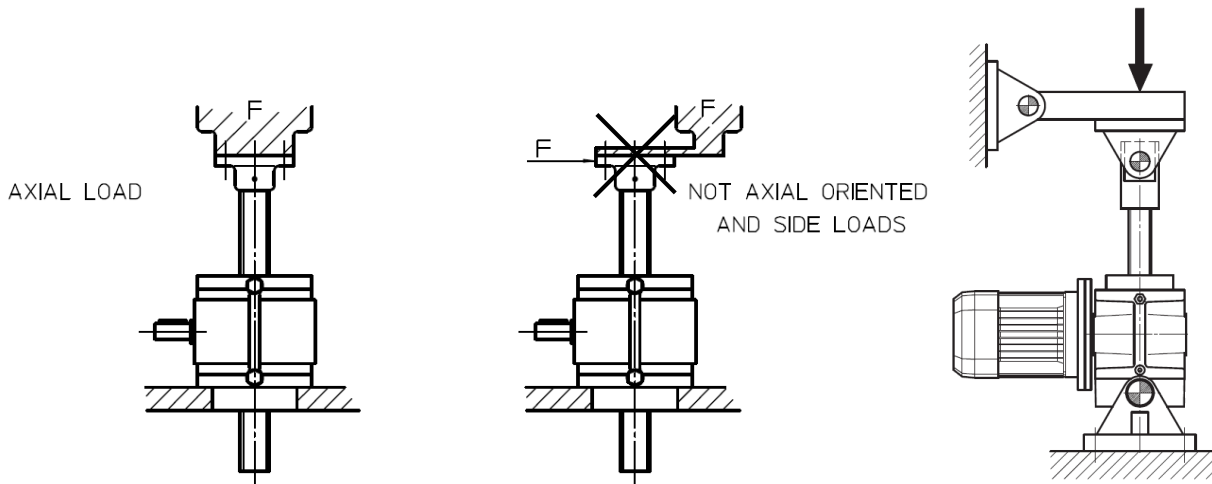

Figure 6.8 – Installation of the screw jack

⚠ RIGHT WORKING OF THE SCREW JACK AND PLANT CANNOT BE GUARANTEED IF SIDE OR NOT AXIAL LOAD ARE APPLIED TO THE BALL SCREW.

6.8 Installation of fitting elements on threaded end

- ⚠ To install a mounting element on the threaded end (NF), fix the ball screw shaft with a clamp to counterhold the locking torque.
- ⚠ In case of screw jack equipped with AR (anti-rotation) device: DO NOT TRANSFER ANY TORQUE TO THE BALL SCREW.
- ⚠ WARNING: in case of torque transfer into the ball screw with AR device, the internal mechanical components can be damaged.
- Fix the threaded element with Loctite 270.
- To unmount the element, heat the threaded area to unlock it.
- Unscrew the fitting element counterholding the torque on the ball screw shaft.

7 COMMISSIONING AND USE

SERVOMECH ball screw jacks are supplied lubricated and ready to be used. Before to start commissioning and activation, the following checks must be carried out:

Shifting direction check

- Check if the push rod shifting direction is compatible to the indications on the control unit, by powering the electric motor on VERY BRIEFLY. If not, see Section 6.6.
- ⚠ For screw jacks without ANTI-ROTATION device (AR): TO ALLOW THE TRANSLATION OF THE BALL SCREW, THE BALL SCREW ROTATION MUST BE REACTED BY USING EXTERNAL GUIDES.

Check of extreme working positions

- Check if the extreme dimensions of the screw jack “Lc” and “La” (see Fig. 6.7) are compatible with extreme positions of the plant component that has to be moved.
 - Measure the initial length of the screw jack, then run the screw jack GRADUALLY from the control unit, in order to reach the plant to its more distant extreme position.
 - Check continuously the current screw jack length during the motion.
 - Repeat the same procedure for the other extreme position.
- ⚠ TO AVOID DAMAGES, DO NOT TRAVEL OVER THE EXTREME STROKE VALUES Lc and La! The Lc and La dimensions are indicated on the check sheet supplied with the product.
- ⚠ DO NOT REACH STROKE END MECHANICAL STOP!

Commissioning

At this stage it is possible to start commissioning:

- Carry out one complete working cycle, without load, adjusting the previously set limit switch positions if necessary (see Sections 6.2.1, 6.3).
- Carry out some complete working cycles, increasing gradually the load, until full load is reached.

8 LUBRICATION

SERVOMECH ball screw jacks MA BS Mod.A Series are supplied lubricated, with lubricants indicated in the table below:

SCREW JACK	GEARBOX	BALL SCREW
MA 5 BS	Grease (NLGI 00 DIN 51818): AGIP Grease SLL 00	Grease (NLGI 1 DIN 51818): LUBCON Thermoplex ALN 1001 Also suitable: FUCHS Renolit AX 2P (NLGI 2) AGIP Grease AC 1 (NLGI 1) MOBIL Mobilgrease FM 101 (NLGI 1) KLUBER Klubersynth UH1 14-151 (NLGI 1)
MA 10 BS		
MA 25 BS	Oil (viscosity at 40°C ASTM D 445: 320 mm/s²): ENI Blasia S 320 Also suitable: SHELL Omala S4 WE 320 CASTROL Alphasyn PG 320 MOBIL Glygoyle 320	
MA 50 BS		
MA 100 BS		
MA 150 BS		
MA 200 BS		
MA 350 BS		

Table 8.1 – Lubricants

- ⚠ DO NOT USE LUBRICANTS DIFFERENT FROM THOSE ABOVE MENTIONED.
- ⚠ DO NOT MIX INCOMPATIBLE LUBRICANTS.
- ⚠ IF DIFFERENT LUBRICANT SHOULD BE USED, PLEASE CONTACT SERVOMECH BEFORE PROCEED.
- ⚠ IN CASE OF CUSTOM PRODUCT EXECUTION, THE LUBRICANTS COULD BE DIFFERENT FROM THE STANDARD ABOVE. TO KNOW THE TYPE OF LUBRICANT PLEASE REFER TO THE PRODUCT CHECK SHEET SUPPLIED WITH THE PRODUCT.

9 MAINTENANCE

- The GEARBOX is long-life lubricated and will not require any further relubrication. Additional lubrication can be done only in case of verified lubricant leakage from the gearbox. In such a case, use the lubricant type indicated in Tab. 8.1 or an equivalent one. The quantity of lubricant to be added depends on the leaked volume.
- The LINEAR DRIVE and the ANTI-ROTATION device require periodic relubrication, according to Table 9.1, or at the latest after 1 year of time. Please use lubricant indicated in Table 8.1 or equivalent.
- Every 2 months time interval: visual inspections of screw jack conditions, cleaning of dirty parts of the screw jack.
- In case of lubricant leakage, contact SERVOMECH.

SCREW JACK	Lead pitch [mm]	Lubrication interval [km of stroke]	BALL SCREW lubricant q.ty	GEARBOX lubricant q.ty	ANTI-ROTATION Lubricant q.ty (each 100mm of stroke)
MA 5 BS	5	50	6 cm ³	—	1 cm ³
	10	100			
	16	160			
MA 10 BS	5	50	7 cm ³	—	1 cm ³
	10	100			
	25	250			
MA 25 BS	10	100	20 cm ³	0.35 liter	1 cm ³
	20	200			
	32	320			
MA 50 BS	10	100	38 cm ³	0.75 liter	1 cm ³
	20	200			
	40	400			
MA 100 BS	10	100	134 cm ³	1.5 liter	2 × 1 cm ³
	20	200			
	40	400			
MA 150 BS	10	100	77 cm ³	1.5 liter	2 × 1 cm ³
	20	200			
	30	300			
	40	400			
MA 200 BS	10	100	145 cm ³	2.3 liter	2 × 2 cm ³
	20	200			
	40	400			
MA 350 BS	16	160	240 cm ³	4 liter	2 × 3 cm ³
	20	200			

Table 9.1 – Maintenance

9.1 Ball screw lubrication

- ⚠ WARNING! THE PLANT MUST BE STOPPED BEFORE BEGINNING ANY MAINTENANCE OPERATION.
- Relube the ball screw using proper grease nipples (comp. n. 10, Fig. 2.1, page 4).
- Grease nipple type: DIN71412 M6.
- Apply the grease quantity indicated in Tab 9.1 with several partial quantities.
- Travel over the entire stroke between one lubricating operation and the next.
- At the end of lubricating procedure, extend and retract the screw jack over its entire stroke for 3 full cycles.
- If necessary, remove excess of lubricant from the ball screw.

9.2 Gearbox lubrication

- ⚠ WARNING! THE PLANT MUST BE STOPPED BEFORE BEGINNING ANY MAINTENANCE OPERATION.
- ⚠ THE REFILL OR REPLACEMENT OF GEARBOX LUBRICANT CAN NOT BE DONE ON MA 5 BS, MA 10 BS SCREW JACKS, AS THEY ARE GREASE LUBRICATED.
- ⚠ The GEARBOX is long-life lubricated. Refill or replace of lubricant can be done only in case of verified lubricant leakage from the gearbox.

9.2.1 Lubricant refill

- Remove the breather plug (comp. n. 6, Fig. 2.1, page 4).
- Add oil type indicated in Tab. 8.1 or equivalent, until the oil level is visible through the oil level plug (comp. n. 8, Fig. 2.1, page 4). The oil level should be approximately in the middle of the inspection plug.
- Replace the sealing washer on the breather plug with a new one and fix it.

9.2.2 Lubricant replacement

- Completely drain the oil inside the housing by removing the drain plug (comp. n. 7, Fig. 2.1, page 4).
- Replace the sealing washer on the drain plug with a new one and fix it on the proper hole.
- Remove the breather plug (comp. n. 6, Fig. 2.1, page 4) and add oil until the oil level is visible through the oil level plug (comp. n. 8, Fig. 2.1, page 4). The oil quantity to be added is roughly the quantity indicated in Tab. 9.1. The oil level should be approximately in the middle of the inspection plug.
- Then replace the sealing washer on the breather plug with a new one and fix it on the proper hole.

9.3 Anti-rotation device lubrication

- ⚠ WARNING! THE PLANT MUST BE STOPPED BEFORE BEGINNING ANY MAINTENANCE OPERATION.
- Before to start lubrication, put the screw jack in RETRACTED POSITION (Lc – see Fig. 6.7).
- Relube the anti-rotation device using proper grease nipple, as shown in Fig. 9.2.
- Grease nipple type: DIN71412 M6
- Apply the grease quantity indicated in Tab 9.1.
- ⚠ IF THERE ARE MORE THAN ONE GREASE NIPPLE, EQUALLY SPLIT THE TOTAL LUBRICANT QUANTITY (SEE TABLE 9.1) BETWEEN THE GREASE NIPPLES.
- ⚠ In case of MA 100 BS, MA 150 BS, MA 200 BS, MA 350 BS screw jacks, please note that 2 anti-rotation tab are placed on the screw jack.
- ⚠ WHEN LUBRICATING THE ANTI-ROTATION DEVICE, THE SCREW JACK MUST ALWAYS BE IN RETRACTED (LC) POSITION. DO NOT LUBRICATE THE ANTI-ROTATION DEVICE IN EXTENDED (LA) OR INTERMEDIATE POSITIONS!
- At the end of lubricating procedure, extend and retract the screw jack over its entire stroke for 3 full cycles.

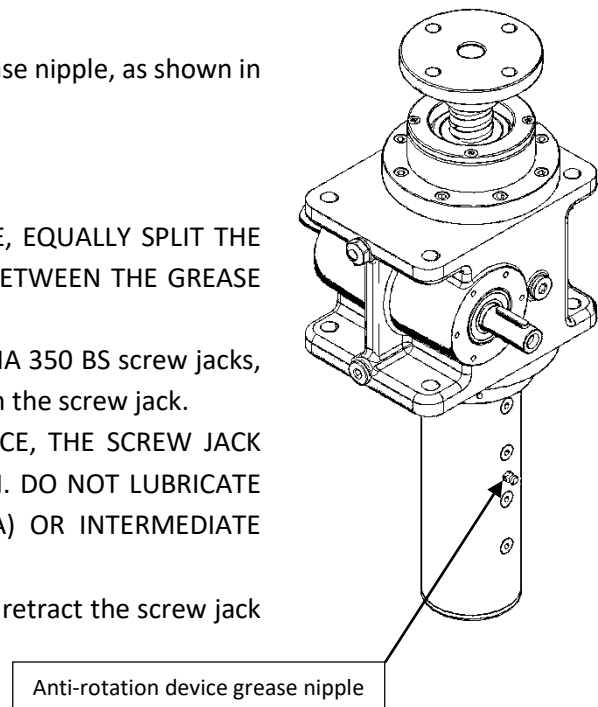

Figure 9.2 – Anti-rotation device lubrication