

MINI  **TECNO**™
small but strong

















Motoriduttori CA
AC gearmotors

AC



MINI  **TECNO**™ brand of
TRANSTECNO®



	Indice	Index	Pag. Page
 	A-A Motori elettrici CA SM	AC Electric motors SM	A-A1
	A-B Motori elettrici CA autofrenanti SM..BR	Braked AC Electric motors SM..BR	A-A1
	A-C Motori elettrici CA servoventilati SM..SV	AC Electric Motors with forced-ventilation SM..SV	A-A1
	A-D Motori elettrici CA SM..UL	AC Electric motors SM..UL	A-A1
 	A-E Motoriduttori CA ad ingranaggi cilindrici CMG	AC Helical in-line garmotors CMG	A-B1
 	A-F Motoriduttori CA ad assi ortogonali CMB	AC Helical bevel garmotors CMB	A-C1
 	A-G Motoriduttori CA pendolari KFT105 - FT	AC Helical parallel garmotors KFT105 - FT	A-D1
	A-H Motoriduttori CA a vite senza fine CM/CMP	AC Wormgarmotors CM/CMP	A-E1
	A-I Motoriduttori CA combinati a vite senza fine CMM	AC Doble reduction wormgarmotors CMM	A-F1
 	A-L Motoriduttori CA epicicloidali P	AC Planetary garmotors P	A-G1
	A-M Motoriduttori CA combinati WMP	AC Doble reduction garmotors WMP	A-H1

Questo catalogo annulla e sostituisce ogni precedente edizione o revisione.
Ci riserviamo inoltre il diritto di apportare modifiche senza preavviso.
La versione più aggiornata è disponibile sul sito
www.transtecno.com

*This catalogue supersedes any previous edition and revision.
We reserve the right to implement modifications without notice.
The most updated version is available on our website
www.transtecno.com*

MINI  **TECNO**™
small but strong

SM



AC

Motori elettrici asincroni CA
AC asynchronous electric motors



MINI  **TECNO**™ brand of
TRANSTECNO®



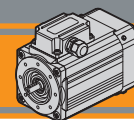

Indice	Index	Pag. Page
Caratteristiche tecniche	<i>Technical features</i>	AA2
Designazione	<i>Classification</i>	AA3
Simbologia e formule	<i>Symbols and formulas</i>	AA3
Dati tecnici motori trifase	<i>Three phase motors technical data</i>	AA4
Dati tecnici motori monofase	<i>Single phase motors technical data</i>	AA5
Dimensioni motori trifase	<i>Three phase motors dimensions</i>	AA6
Dimensioni motori monofase	<i>Single phase motors dimensions</i>	AA8
Cava esagonale	<i>Hexagonal socket</i>	AA10
Opzione guarnizione CA	<i>Rubber gasket option</i>	AA10
Gradi di protezione IP	<i>IP protection rating</i>	AA11
Normative di riferimento	<i>Reference standards</i>	AA11
Tipo di servizio IEC	<i>IEC duty cycles</i>	AA12
Classe di isolamento termico	<i>Insulation class</i>	AA12
Serie SM - Funzionamento a 60 Hz	<i>Series SM - 60 Hz line power supply</i>	AA13
Tabella pressacavi	<i>Table of cable glands data</i>	AA13
Connessioni e collegamenti	<i>Connection diagram</i>	AA13
Targhetta	<i>Nameplate</i>	AA18

Questa sezione annulla e sostituisce ogni precedente edizione o revisione. Qualora questa sezione non Vi sia giunta in distribuzione controllata, l'aggiornamento dei dati ivi contenuto non è assicurato. **In tal caso la versione più aggiornata è disponibile sul nostro sito internet www.transtecno.com**

This section replaces any previous edition and revision. If you obtained this catalogue other than through controlled distribution channels, the most up to date content is not guaranteed. In this case the latest version is available on our web site www.transtecno.com

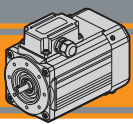

Caratteristiche tecniche

Technical characteristics

I motori delle serie SMT ed SMM hanno le seguenti caratteristiche principali:

SMT and SMM motor range has the following main features:

- Costruzione compatta
 - Motorizzazioni in corrente alternata monofase e trifase
 - Carcassa estrusa in alluminio anodizzato nero
 - Motore elettrico AC con grado di protezione IP66 eccetto il condensatore.
 - Rumorosità e vibrazioni contenute
 - Isolamento termico di classe F
 - Flangia motore IEC B14
 - Temperatura ambiente: -20°C / +40°C
 - Disponibili sia nella versione ventilata TEFC (servizio S1) che non ventilata TENV (servizio S3)
 - Protezione termica PTO 150°C per le taglie 56, 63 e 71.
 - SMT56, SMT63 e SMT71 adatti al funzionamento con alimentazione da inverter.
 - Cava esagonale su albero motore lato NDE.
 - Condensatore di marcia sempre cablato ad esclusione della taglia SMM50.
 - La tolleranza di tensione è $\pm 10\%$ per tutti i motori ad esclusione della taglia 50 ($\pm 5\%$).
 - Disponibili nelle versioni autofrenante, servoverilata e con certificazione UL.
- *Compact design*
 - *AC single phase and three phase motors available*
 - *Black anodized extruded aluminium housing*
 - *AC electric motor in IP66 protection Standard, except capacitor*
 - *Low noise and vibrations*
 - *Class F insulation Standard*
 - *Motor flange IEC B14*
 - *Ambient temperature: -20°C / +40°C*
 - *Fan cooled TEFC (duty S1) and not ventilated TENV (duty S3) versions available*
 - *PTO 150°C thermal protection for motor sizes 56, 63 and 71.*
 - *SMT56, SMT63 and SMT71 are suitable for inverter duty.*
 - *Motor shaft hexagon socket on the NDE side.*
 - *Running capacitor always connected, except for SMM50.*
 - *The voltage tolerance is $\pm 10\%$ for all motors, except for size 50 ($\pm 5\%$).*
 - *Brake motors, forced ventilation motors and UL compliance versions available.*

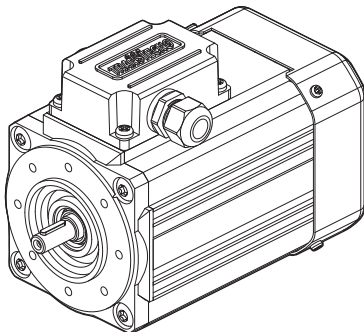

SM .. TEFC

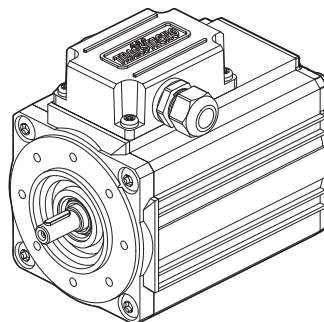

SM .. TENV



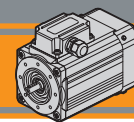

Designazione
Classification

MOTORE TRIFASE / THREE PHASE MOTOR									
SMT	63	2	4	0.18 kW	B14	230-400 V	50 Hz	TEFC	BR
Tipo Type	Grandezza Size	Indicativo potenza Power coefficient	Poli Poles	Potenza Power	Forma costruttiva Version	Tensione Voltage	Frequenza Frequency	Ventilazione Fan cooling	Opzioni Options
SMT 	Vedi tabelle See tables	1-2-3-4-5	4	0.04 kW ... 0.75 kW	B14	230-400 V 460V	50Hz 60Hz	TEFC TENV	BR → SV → UL-CSA →

MOTORE MONOFASE / SINGLE PHASE MOTOR									
SMM	63	2	4	0.18 kW	B14	230 V	50 Hz	TEFC	-
Tipo Type	Grandezza Size	Indicativo potenza Power coefficient	Poli Poles	Potenza Power	Forma costruttiva Version	Tensione Voltage	Frequenza Frequency	Ventilazione Fan cooling	Opzioni Options
SMM 	Vedi tabelle See tables	1-2-3-4	4	0.04 kW ... 0.55 kW	B14	230V 115V (UL-CSA)	50Hz	TEFC TENV	UL-CSA →

Simbologia e formule
Symbols and formulas

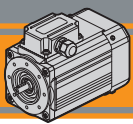
P_n	[kW]	Potenza nominale	<i>Rated power</i>
I_n	[A]	Corrente nominale (a 400V)	<i>Rated current (at 400V)</i>
M_n	[Nm]	Coppia nominale	<i>Rated torque</i>
n_n	[rpm]	Velocità nominale	<i>Rated speed</i>
M_s / M_n		Rapporto coppia spunto / coppia nominale	<i>Ratio start torque / rated torque</i>
M_k / M_n		Rapporto coppia massima / coppia nominale	<i>Ratio max torque / rated torque</i>
I_s / I_n		Rapporto corrente di spunto / corrente nominale	<i>Ratio start current / rated current</i>
$\cos\varphi$		Fattore di potenza al carico nominale	<i>Power factor at rated torque load</i>
η		Rendimento al carico nominale	<i>Efficiency at rated torque load</i>
Potenza <i>Power</i>	[HP]	Potenza [kW] x 1.341	<i>Power [kW] x 1.341</i>
Potenza resa P_n <i>P_n output power</i>	[kW]	Potenza assorbita x η	<i>Absorbed power x η</i>
Pot. assorbita <i>Absorbed power</i>	[kW]	$\frac{\sqrt{x} \cdot I \cdot \cos\varphi}{1000}$ (monofase)	$\frac{\sqrt{x} \cdot I \cdot \cos\varphi}{1000}$ (singlephase)
		$\frac{\sqrt{x} \cdot I \cdot \sqrt{3} \cdot \cos\varphi}{1000}$ (trifase)	$\frac{\sqrt{x} \cdot I \cdot \sqrt{3} \cdot \cos\varphi}{1000}$ (threephase)
I_n (230 V)		I_n (400 V) x $\sqrt{3}$	I_n (400 V) x $\sqrt{3}$



Dati tecnici motori trifase

Three phase motors technical data

SMT Motori trifase / SMT Three phase motors

(230-400 V / 50 Hz) poli / poles **4**

	TAGLIA SIZE	P _n [kW]	M _n [Nm]	n _n [min ⁻¹]	I _n (400V) [A]	η %	cosφ	M _s /M _n	I _s /I _n	M _k /M _n	PTO [°C]	Servizio Duty TEFC	Servizio Duty TENV
	5014	0.04	0.30	1290	0.25	34.0	0.68	1.65	1.75	1.70	-	S1	S3 30%
	5024	0.06	0.44	1300	0.35	35.7	0.69	1.55	1.80	1.60			
	5034	0.09	0.65	1315	0.54	38.0	0.64	1.80	2.00	1.85			
	5044	0.12	0.87	1315	0.64	43.0	0.63	1.80	2.00	1.80			
	5624	0.09	0.64	1345	0.45	46.5	0.62	2.50	2.40	2.70	PTO 150°	S1	S3 50%
	5634	0.12	0.89	1300	0.45	52.0	0.74	1.90	2.40	1.90		S3 75%	
IE2	5634 IE2	0.12	0.84	1360	0.48	59.1	0.61	2.70	2.90	2.70		S1	-
	5644	0.18	1.26	1360	0.69	59.0	0.65	2.50	3.00	2.60		S3 75%	S3 50%
	5654	0.25	1.80	1330	0.93	59.0	0.66	2.50	2.80	2.60			
	6324	0.18	1.26	1360	0.69	57.0	0.66	2.50	2.90	2.50		S1	-
IE2	6324 IE2	0.18	1.27	1360	0.65	64.7	0.62	2.50	2.90	2.50			
	6334	0.25	1.74	1375	0.94	62.0	0.64	2.80	3.00	2.80		S3 75%	S3 50%
IE2	6334 IE2	0.25	1.72	1390	0.88	68.5	0.60	3.20	3.50	3.20		S1	-
	6344	0.37	2.60	1360	1.24	65.3	0.66	2.70	3.00	2.70		S3 75%	S3 50% S3 45%
	7124	0.37	2.52	1400	1.10	67.9	0.72	2.75	4.20	2.75			
IE2	7124 IE2	0.37	2.48	1425	1.05	72.7	0.70	2.80	4.90	2.90		S1	-
	7134	0.55	3.76	1395	1.55	70.2	0.73	2.90	4.40	2.90		S3 75%	S3 45%
IE2	7134 IE2	0.55	3.70	1420	1.56	77.1	0.66	3.40	5.20	3.40			
	7144	0.75	5.09	1405	2.00	74.0	0.73	2.90	5.00	2.90		S3 75%	S3 45%
IE3	8024 IE3	0.75	4.96	1440	1.94	82.5	0.68	3.60	6.00	3.70		S1	S3 70%
	8034 IE3	1.1	7.25	1450	2.91	84.1	0.65	4.00	6.80	4.40			
	9024 IE3	1.5	10.0	1430	3.48	85.3	0.73	3.20	6.30	3.50			
	9034 IE3	2.2	14.9	1410	4.68	86.7	0.79	3.00	6.20	3.30	S3 75%		

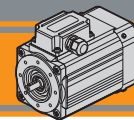

Dati tecnici motori monofase

Single phase motors technical data

SMM Motori monofase / **SMM** Single phase motors

 (230 V / 50 Hz) poli / poles **4**

TAGLIA SIZE	P _n [kW]	M _n [Nm]	n _n [min ⁻¹]	I _n (230V) [A]	η %	cosφ	M _s /M _n	I _s /I _n	M _k /M _n	Cond/cap [μF]	PTO [°C]	Servizio Duty TEFC	Servizio Duty TENV
5014	0.04	0.27	1390	0.60	33.4	0.88	0.74	1.60	1.55	8.0	-	S1	S3 30%
5024	0.06	0.42	1380	0.89	34.3	0.85	0.76	1.70	1.50	12.0			
5034	0.09	0.63	1375	1.10	40.0	0.89	0.80	1.70	1.45	16.0	PTO 150°	S3 75%	S3 50%
5624	0.09	0.63	1370	0.82	48.6	0.98	0.72	1.70	1.45	6.3			
5634	0.12	0.83	1380	1.06	50.3	0.98	0.75	2.10	1.65	9.0			
5644	0.18	1.25	1375	1.50	53.8	0.97	0.70	2.20	1.58	12.5			
6324	0.18	1.33	1290	1.50	54.5	0.97	1.00	1.80	1.45	12.0			
6334	0.25	1.85	1290	1.95	56.8	0.98	0.93	1.90	1.50	16.0			
7124	0.37	2.72	1300	2.78	58.6	0.99	0.77	2.00	1.35	20.0			
7134	0.55	3.95	1330	3.54	68.9	0.98	0.66	2.40	1.40	25.0			
8024	0.75	5.31	1350	4.93	67.4	0.98	0.67	2.50	1.54	35.0		S3 45%	
													S3 40%

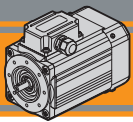

Dimensioni motori trifase

Three phase motors dimensions

3~

SMT50.. - B14 - TEFC / TENV

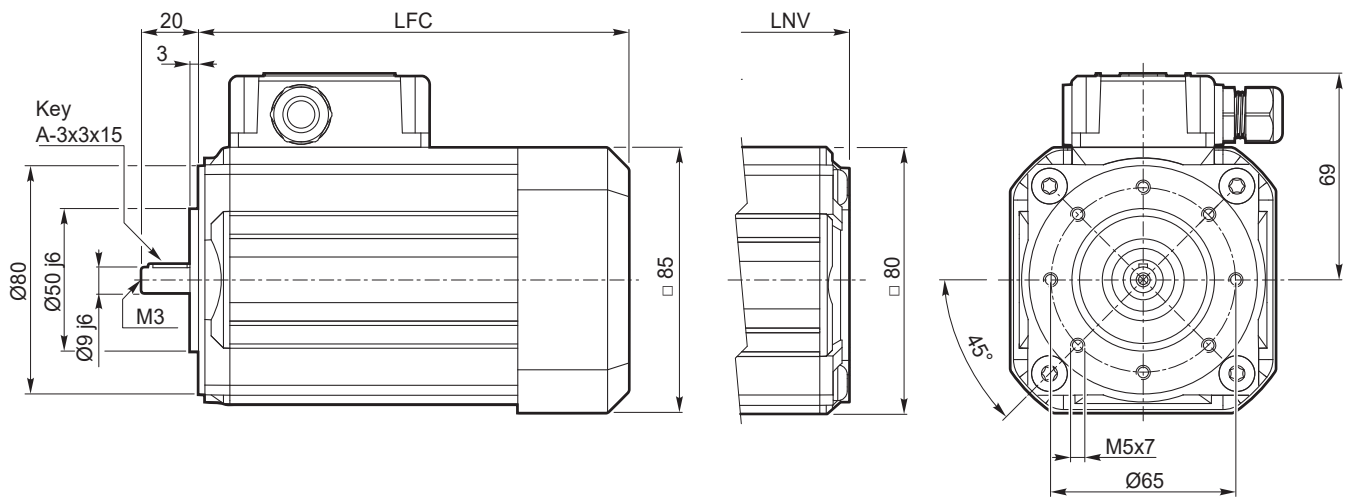

SMT	... TEFC		... TENV	
	LFC	kg	LNV	kg
5014	135.5	2.3	108.5	2.2
5024	150.5	2.7	123.5	2.6
5034	175.5	3.5	148.5	3.4
5044	200.5	4.2	173.5	4.1

3~

SMT56.. - B14 - TEFC / TENV

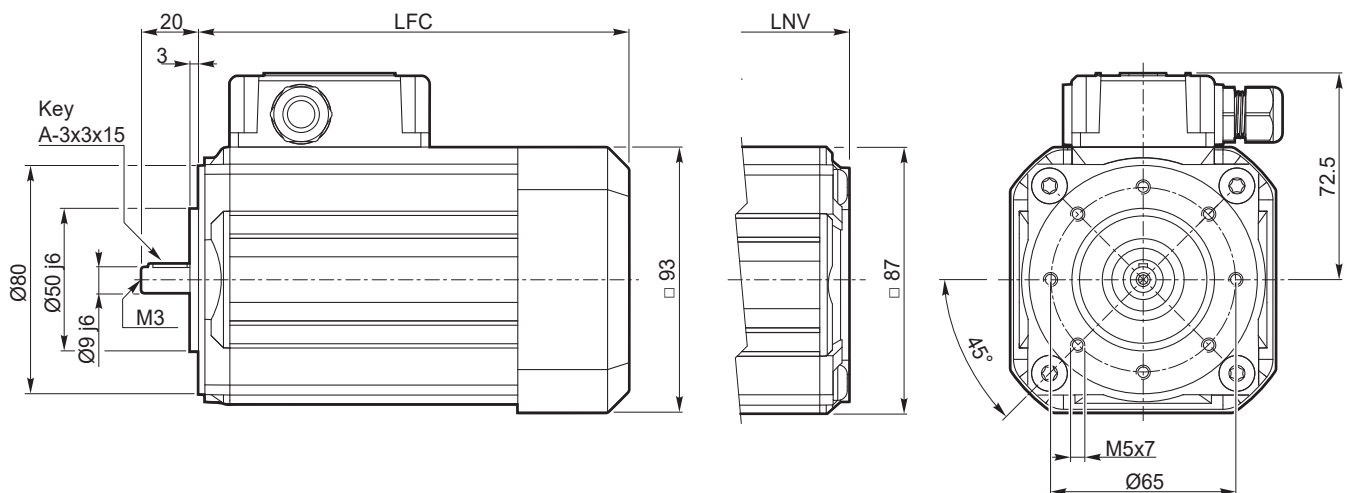

SMT	... TEFC		... TENV	
	LFC	kg	LNV	kg
5624	141	2.9	117	2.8
5634	151	3.2	127	3.1
5634 IE2	171	3.8	-	-
5644	186	4.4	162	4.3
5654	206	5.1	182	5.0

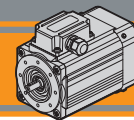

Dimensioni motori trifase

Three phase motors dimensions

3 ~

SMT63.. - B14 - TEFC / TENV

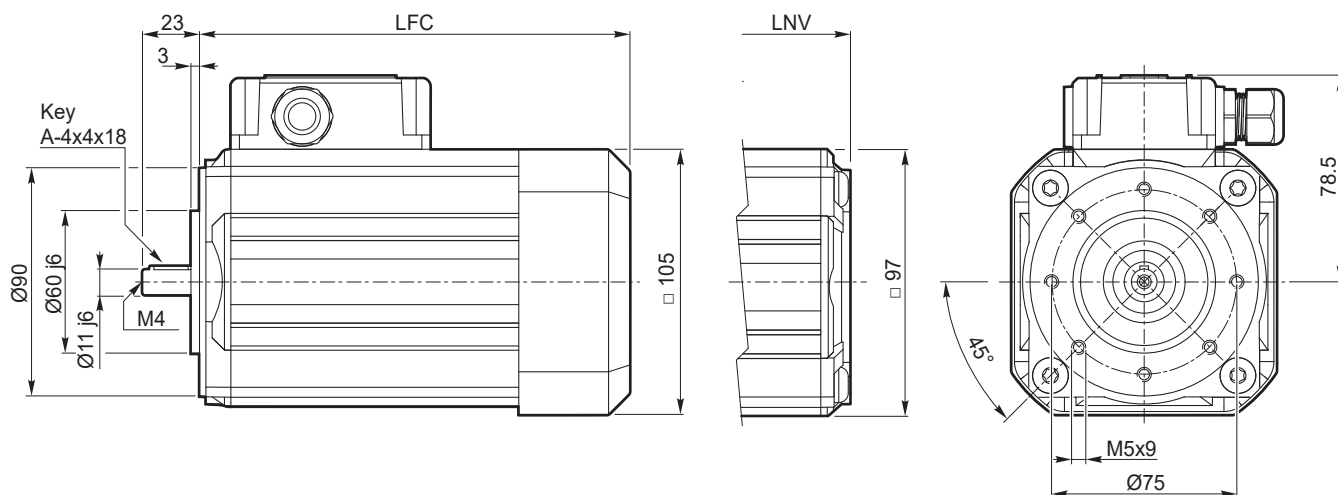

SMT	... TEFC		... TENV	
	LFC	Kg	LNV	Kg
6324	165.5	4.3	138.5	4.2
6324 IE2	180.5	4.9	-	-
6334	180.5	5.0	153.5	4.9
6334 IE2	205.5	6.1	-	-
6344	205.5	6.2	178.5	6.1

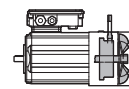

AB4

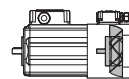
 SM..BR..
 Motori autofrenanti
 Brake motors

AC4

 SM..V..
 Motori servoventilati
 Motors with forced-ventilation

3 ~

SMT71.. - B14 - TEFC / TENV

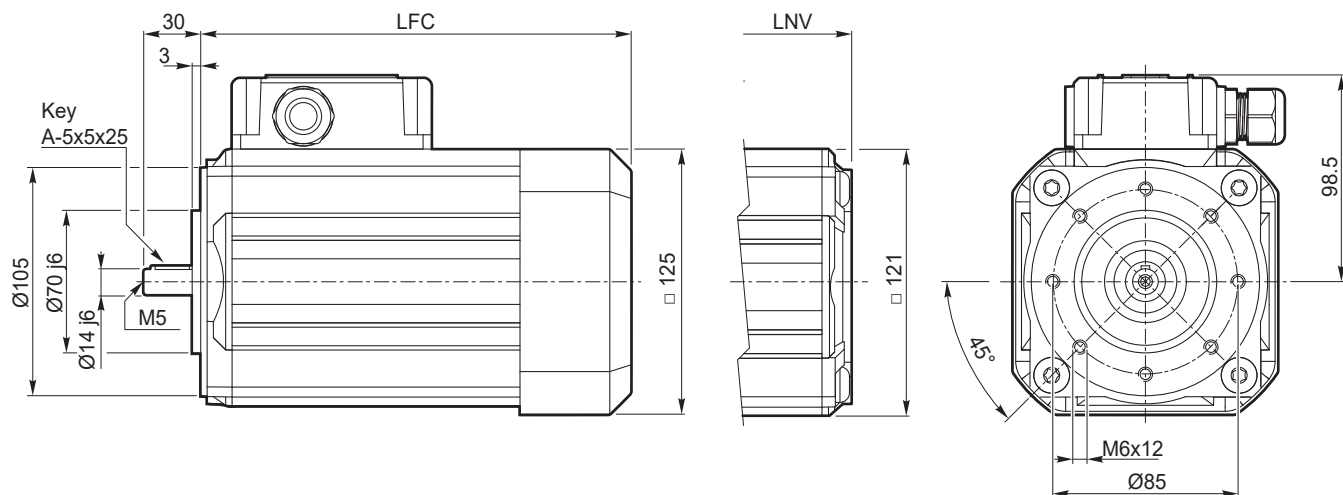

SMT	... TEFC		... TENV	
	LFC	Kg	LNV	Kg
7124	174	6.6	145.5	6.4
7124 IE2	189	7.5	-	-
7134	189	7.7	160.5	7.5
7134 IE2	214	9.2	-	-
7144	214	9.4	185.5	9.2

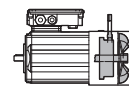

AB4

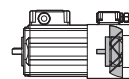
 SM..BR..
 Motori autofrenanti
 Brake motors

AC4

 SM..V..
 Motori servoventilati
 Motors with forced-ventilation

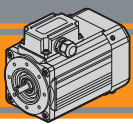

Dimensioni motori monofase

Single phase motors dimensions

1 ~

SMM50.. - B14 - TEFC / TENV

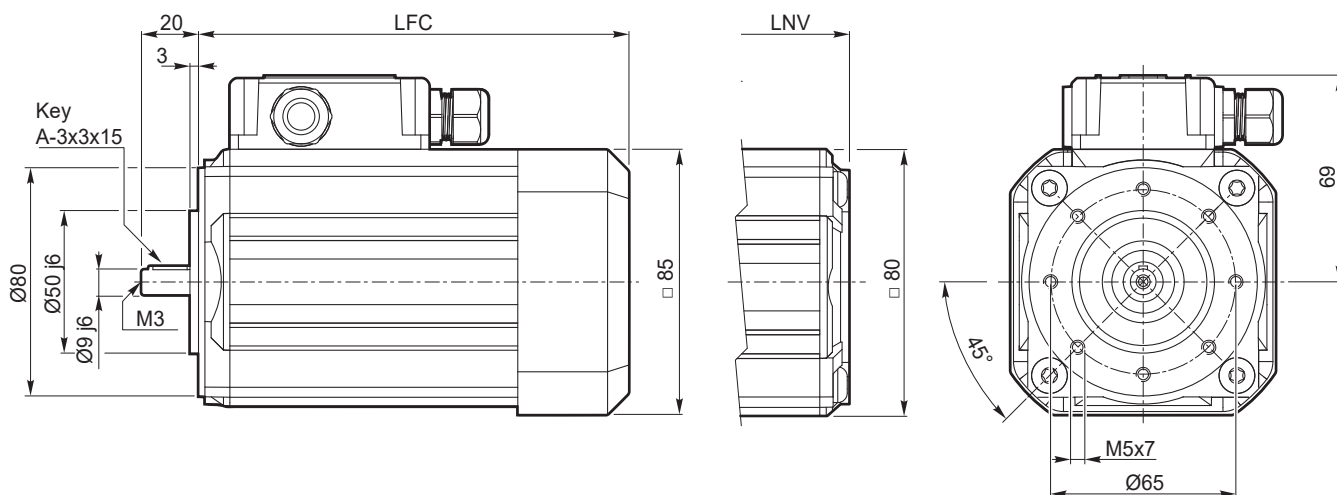

SMM	... TEFC		... TENV	
	LFC	kg	LNV	kg
5014	150.5	2.7	123.5	2.6
5024	175.5	3.5	148.5	3.4
5034	200.5	4.2	173.5	4.1

Nota:
il condensatore sarà fornito a corredo

Note:
the capacitor will be supplied separately

1 ~

SMM56.. - B14 - TEFC / TENV

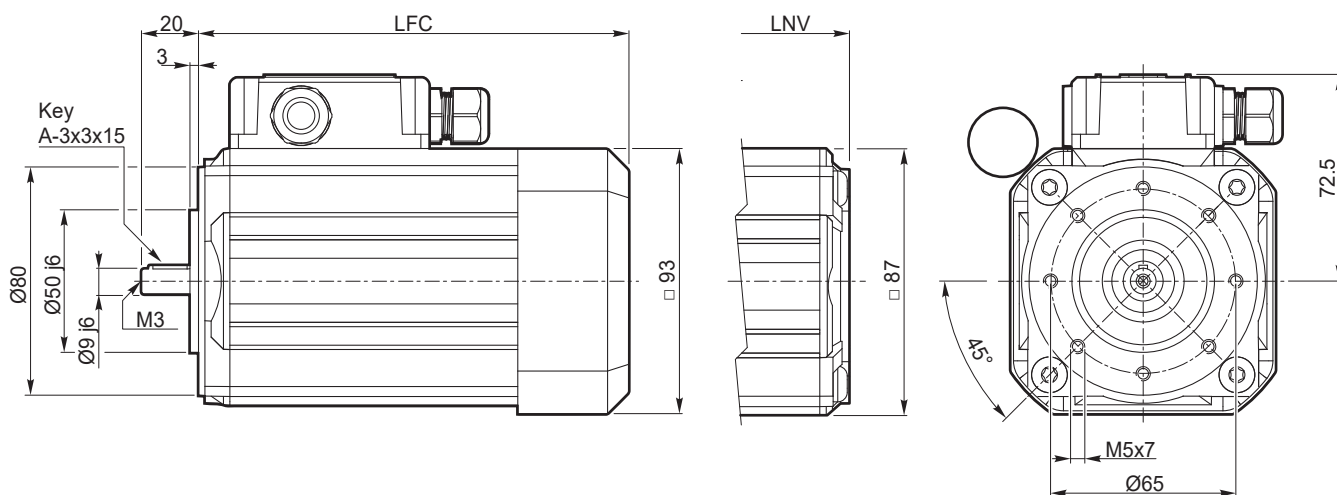

SMM	... TEFC		... TENV	
	LFC	kg	LNV	kg
5624	151	3.3	127	3.2
5634	171	3.9	147	3.8
5644	206	5.0	182	4.9

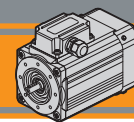

Dimensioni motori monofase

Single phase motors dimensions

1 ~

SMM63.. - B14 - TEFC / TENV

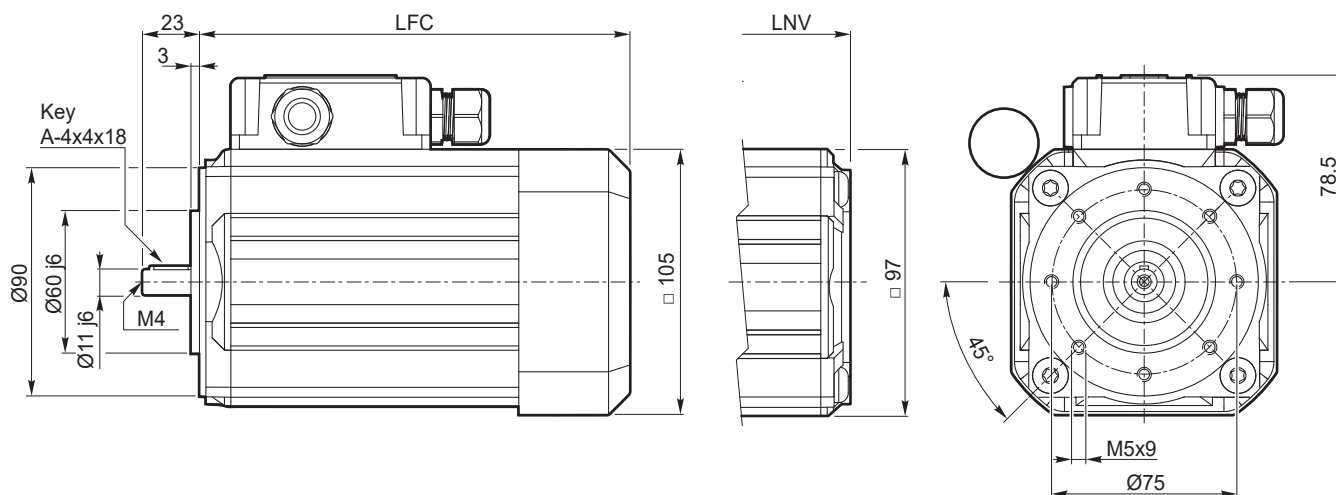

SMM	... TEFC		... TENV	
	LFC	kg	LNV	kg
6324	180.5	5.1	153.5	5.0
6334	205.5	6.2	178.5	6.1

1 ~

SMM71.. - B14 - TEFC / TENV

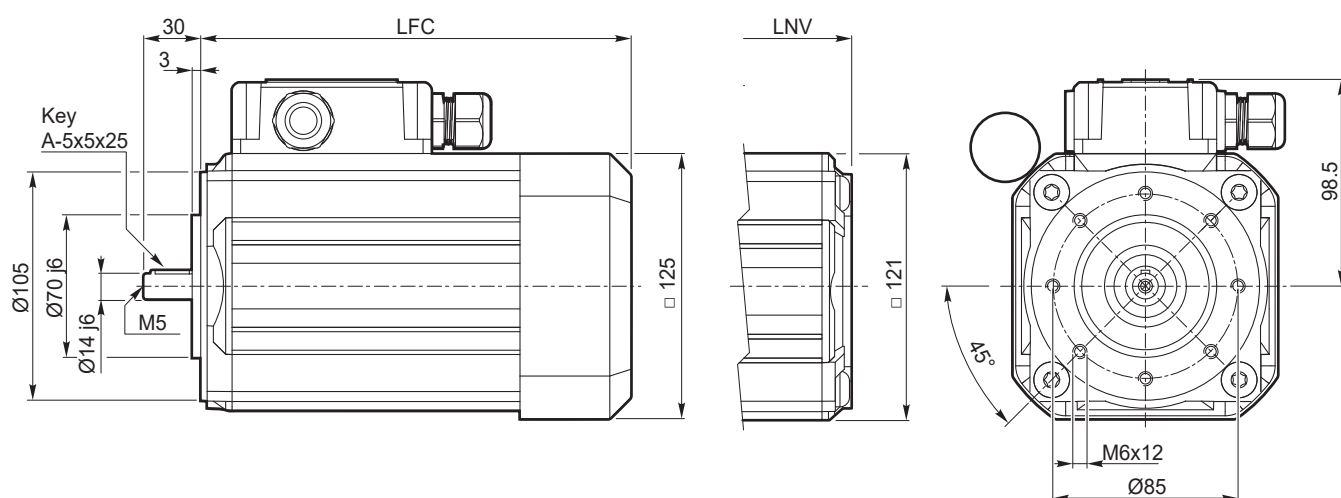

SMM	... TEFC		... TENV	
	LFC	kg	LNV	kg
7124	189	7.3	160.5	7.1
7134	214	9.2	185.5	9.0

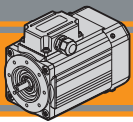

Cava esagonale

Hexagonal socket

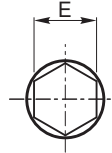
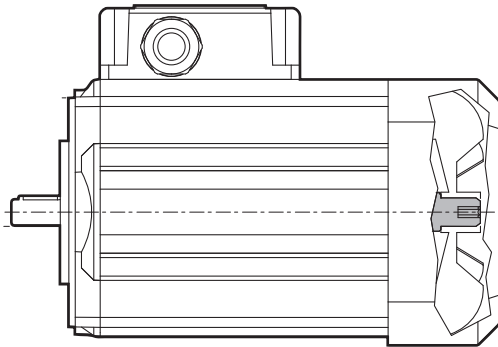

Esagono / Hexagon

SM..	E
50	
56	4
63	
71	6

Nota:

Installare a monte dell'alimentazione un dispositivo che assicuri la disconnessione della rete onnipolare, durante le operazioni di rotazione manuale è obbligatorio l'utilizzo di tale sezionatore.

Il quadro elettrico del motore deve essere lucchettabile al fine di evitare il riarmo non previsto alla rete elettrica.

E' severamente vietata la messa in servizio del motore elettrico senza copriventola opportunamente montata.

Note:

An omnipolar cut-off device must be fitted upstream of the power supply; the use of this device is mandatory during manual rotation operations.

The switchgear for the motor must be padlockable in order to prevent the power supply from being accidentally reset. It is strictly prohibited to put the electric motor into service if the fan cover is not fitted.

Opzione guarnizione CA

Rubber gasket option

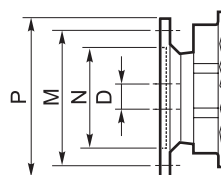
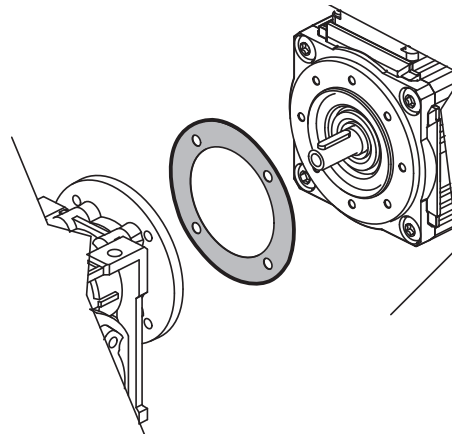

Dimensioni IEC / IEC Dimensions			
	56 B14	63 B14	71 B14
N	50	60	70
M	65	75	85
P	80	90	105
D	9	11	14

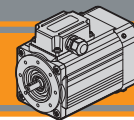
Grado di protezione IP
IP protection rating

Indica il grado di isolamento meccanico del corpo motore.















1^a cifra protezione alla penetrazione di corpi solidi.

2^a cifra protezione contro la penetrazione d'acqua.

IP protection rating indicates the degree of mechanical insulation of the motor casing.

The 1st figure indicates the level of protection against the intrusion of solid matter.

The 2nd figure indicates to which degree the motor is waterproof.

IP		Definizione / Description	IP		Definizione / Description
0		Non protetto / No protection	0		Non protetto / No protection
1		Protetto da corpi solidi superiori a Ø 50 mm. Protected against solid matter (over Ø 50 mm).	1		Protetto contro la caduta verticale di gocce d'acqua. Protected against drops of water falling vertically.
2		Protetto da corpi solidi superiori a Ø 12 mm. Protected against solid matter (over Ø 12 mm).	2		Protetto contro la caduta verticale di gocce d'acqua con inclinazione max di 15°. Protected against drops of water falling up to 15°.
3		Protetto da corpi solidi superiori a Ø 2.5 mm. Protected against solid matter (over Ø 2.5 mm).	3		Protetto contro la pioggia. Rain proof.
4		Protetto da corpi solidi superiori a Ø1 mm. Protected against solid matter (over Ø1 mm).	4		Protetto contro gli spruzzi. Splash proof.
5		Protetto contro la polvere. Dust protected.	5		Protetto contro getti d'acqua. Water jet proof.
6		Totalmente protetto contro la polvere. Fully dust tight.	6		Protetto dalle ondate. Waveproof.
7		N.A.	7		Protetto contro immersione. Immersion up to 1 metre.
8		N.A.	8		Protetto contro immersione/sommersione prolungata. Immersion beyond 1 metre.

Normative di riferimento
Reference Standards

	Europe EN	World IEC	Italy CEI
Requisiti generali per macchine elettriche <i>General requirements electrical machines</i>	EN 60034-1:2010	IEC 60034-1:2010	CEI EN 60034-1:2010
Classificazione del grado di protezione <i>Classification degree of protection provided by enclosures</i>	EN 60034-5:2001	IEC 60034-5:2001	CEI EN 60034-5:2001
Sistema di raffreddamento <i>Cooling system</i>	EN 60034-6:1993	IEC 60034-6:1993	CEI EN 60034-6:1993
Modalità di montaggio <i>Mounting arrangements</i>	EN 60034-7:1993	IEC 60034-7:1993	CEI EN 60034-7:1993

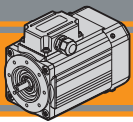

Tipi di servizi IEC

IEC duty cycles

Il servizio di un motore indica il tipo di utilizzo e la gravosità del ciclo di lavoro.

The duty cycle of a motor indicates its use and running cycle.

Grafico servizi più comuni

Most common duty cycles diagram

N = funzionamento / run
R = riposo / rest

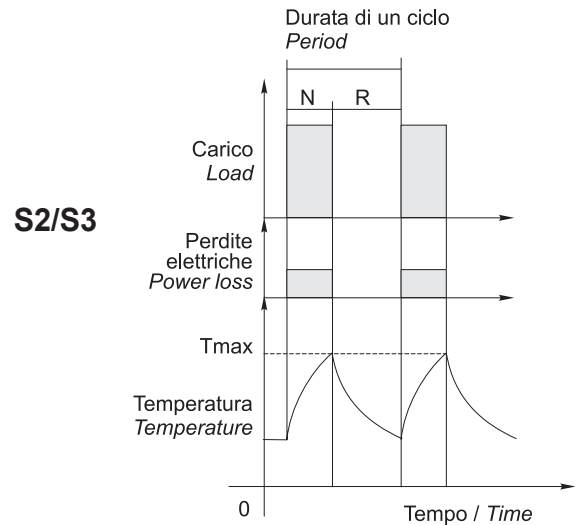
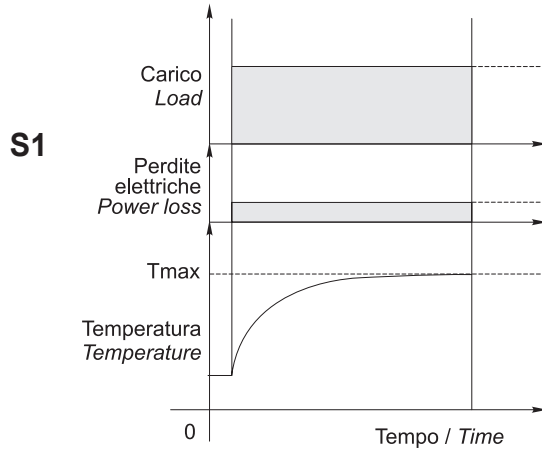

NOTA: Lo stesso motore può essere usato per cicli e servizi diversi, con l'unica limitazione che la temperatura interna non superi mai la Tmax stabilita dalla classe di isolamento termico del motore.

NOTE: The same motor can run under all duty services, limitation is due to internal temperature that must not override Tmax stated by motor thermal class.

Classe di isolamento termico

Insulation class

La classe termica indica il grado di resistenza alla temperatura interna, nel punto più caldo (avvolgimenti). Isolamento termico classe F.

Thermal insulation class indicates the level of thermal protection measured at the hottest point inside the motor (windings). Thermal insulation class F.

Classe Class	Massima temperatura interna Max. windings temp.
E	120°C
B	130°C
F	155°C
H	180°C

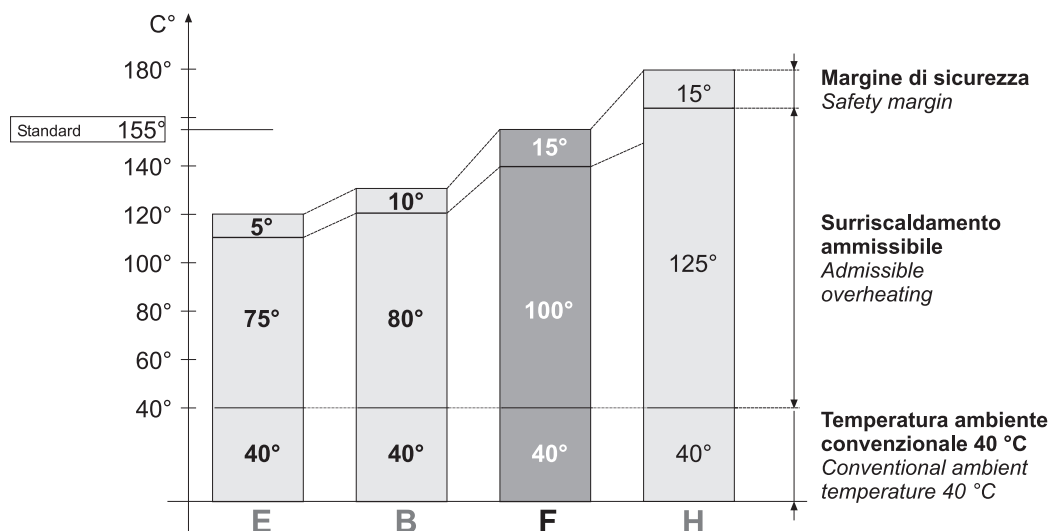

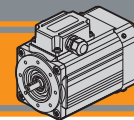

Serie SM - Funzionamento a 60 Hz

Series SM - 60 Hz line power supply

Velocità, coppia e potenza nominale nel funzionamento a 60 Hz varieranno come da tabella:

Speed, torque and rated power in 60 Hz operation is shown in the following table:

	50 Hz	60 Hz
400 V	Vedi dati tecnici / see technical data 	Velocità / speed ≈ + 20% Coppia / torque ≈ -20% Potenza / power ≈ invariata / the same
480 V	Non permesso / not allowed	Velocità / speed ≈ + 20% Coppia / torque ≈ invariata / the same Potenza / power ≈ + 20%

Tabella pressacavi

Table of cable glands data

Serie SMT / SMT Series

Serie SMM / SMM Series

TAGLIA SIZE	Pressacavo Cable gland
50 / 56 / 63	M16x1.5
71	M20x1.5

TAGLIA SIZE	Pressacavo Cable gland
50 / 56 / 63	n°2 - M16x1.5
71	M20x1.5 + M16x1.5

Connessioni e collegamenti

Connection diagram

Riferimenti

References

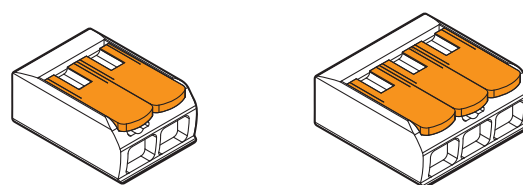
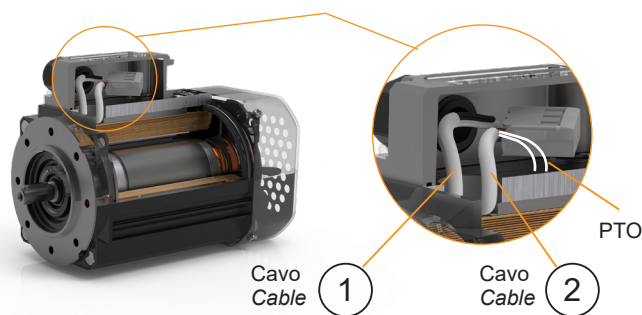

Morsetto di collegamento a leva a 2 e 3 poli
Splicing connector with lever 2 - and 3 - pin.

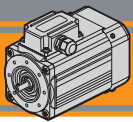

Connessioni e collegamenti

Connection diagram

400/460 V - Trifase / Three phase

Collegamento a stella / Star connection

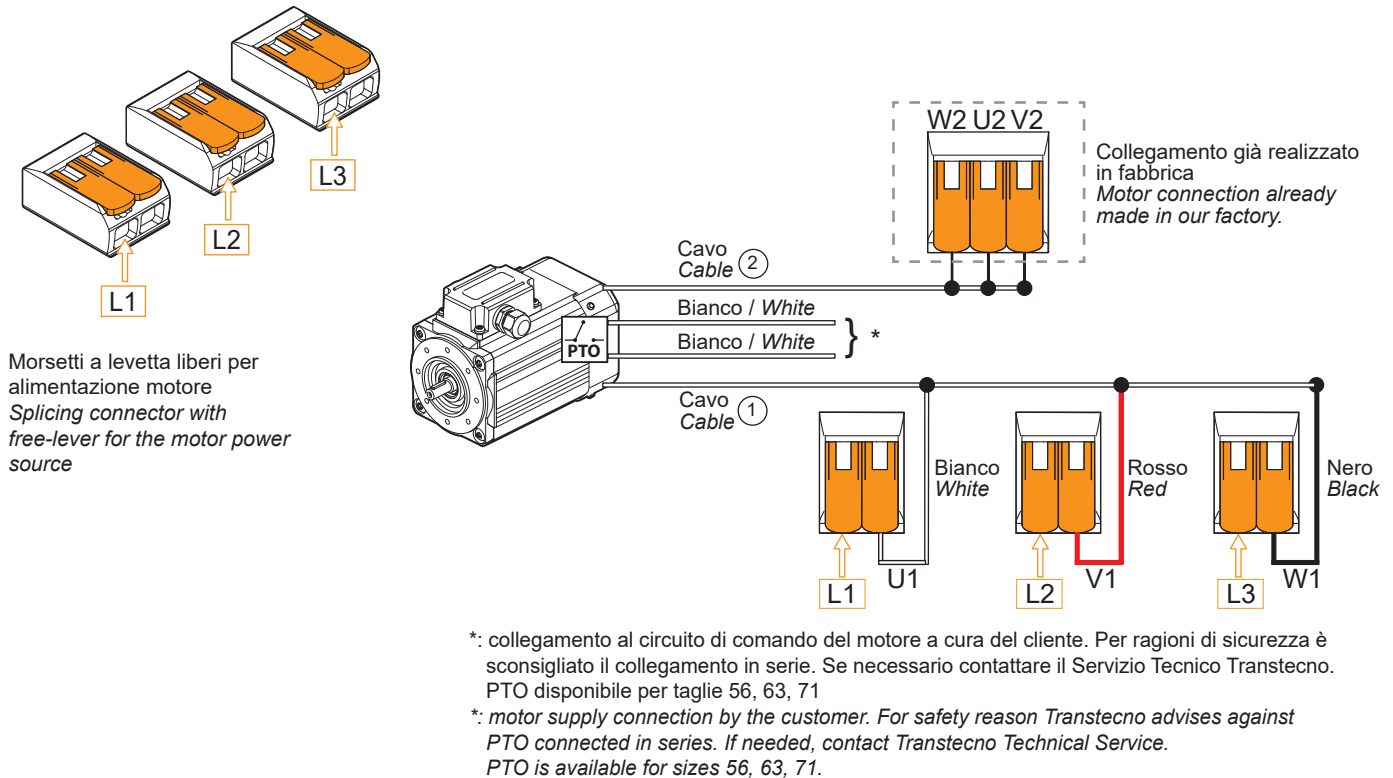

230 V - Trifase / Three phase

Collegamento a triangolo / Delta connection

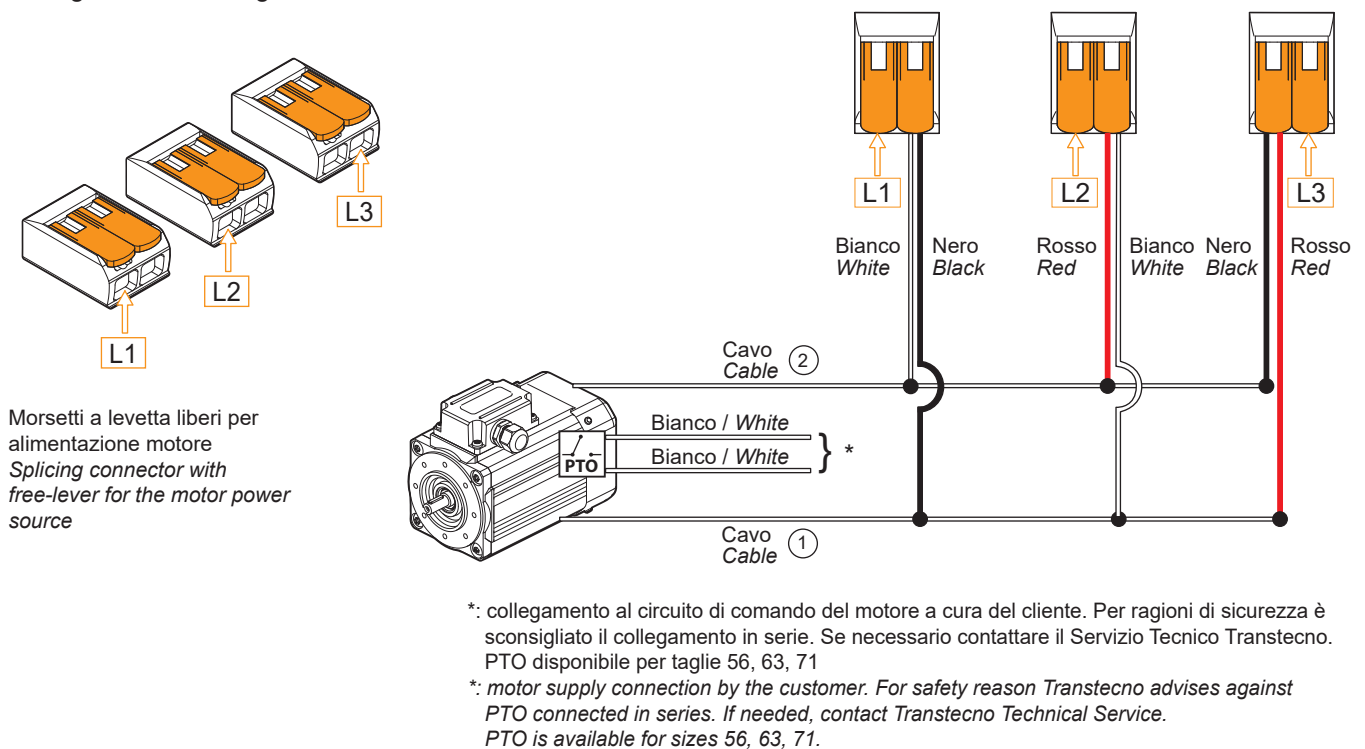

I motori della serie SM sono forniti in collegamento a stella, lo schema di collegamento a triangolo sopra riportato fornisce una chiara indicazione delle modifiche che il cliente può apportare in autonomia. Se necessario contattare il Servizio Tecnico Transtecno.

The SM series is supplied in star connection, the delta connection diagram shown above provides a clear indication of the modification that the customer can make independently. If needed, contact Transtecno Technical Service.

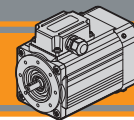

Connessioni e collegamenti

Connection diagram

230 V - Monofase / Single phase

Monofase SMM 50... / Single phase SMM 50...

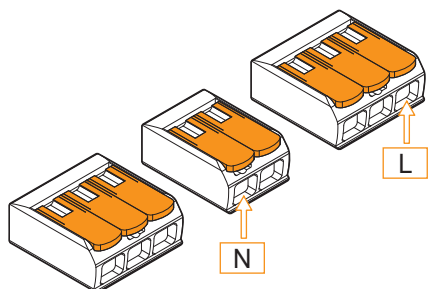

Morsetti a levetta liberi per alimentazione motore
Splicing connector with free-lever for the motor power source

(1): il condensatore sarà fornito a corredo.
(1): the capacitor will be supplied separately.

Senso di rotazione antiorario
Counter-clockwise direction of rotation

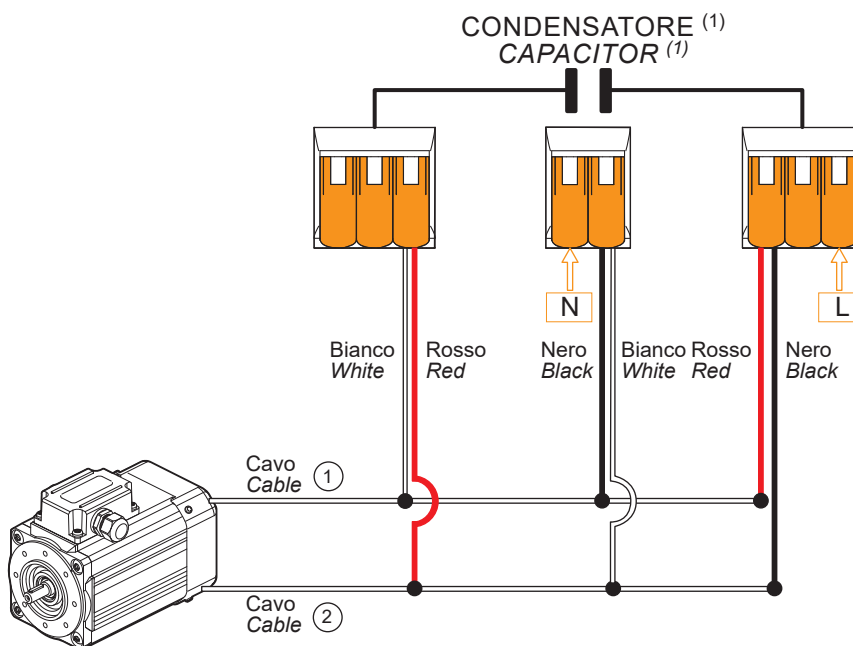
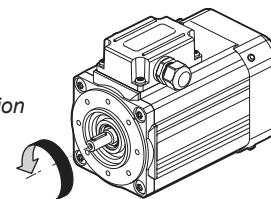

230 V - Monofase / Single phase

Monofase SMM 50... / Single phase SMM 50...

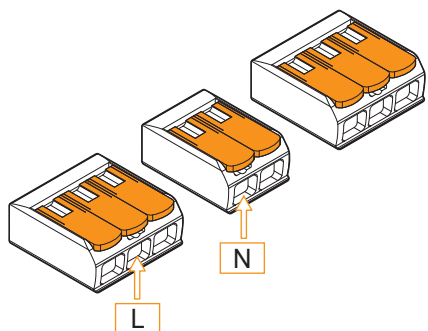

Morsetti a levetta liberi per alimentazione motore
Splicing connector with free-lever for the motor power source

(1): il condensatore sarà fornito a corredo.
(1): the capacitor will be supplied separately.

Senso di rotazione orario
Clockwise direction of rotation

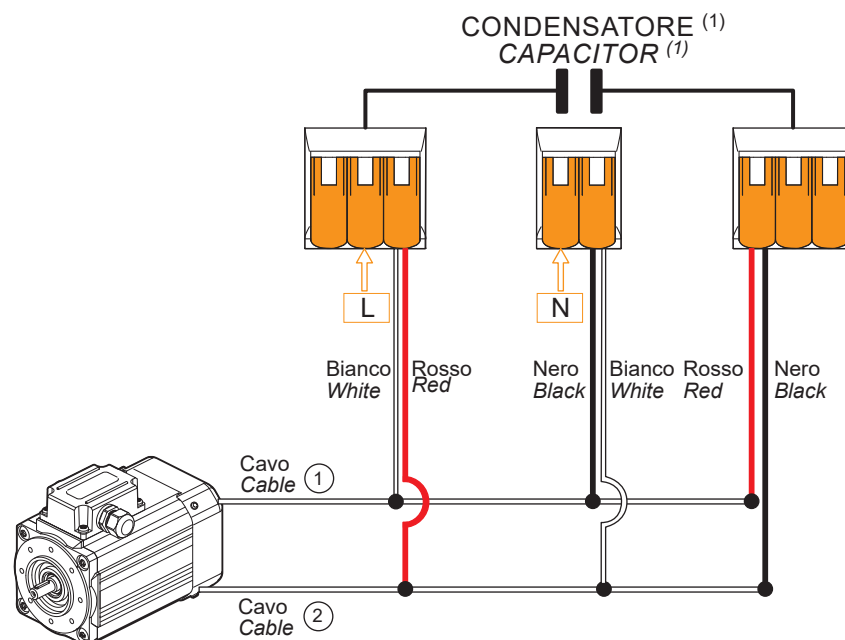
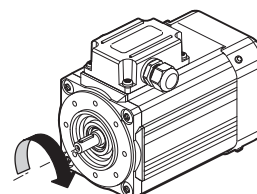

AC

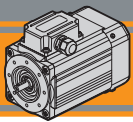

Connessioni e collegamenti

Connection diagram

230 V - Monofase / Single phase

Monofase da SMM 56... a SMM 71... / Single phase from SMM 56... to SMM 71...

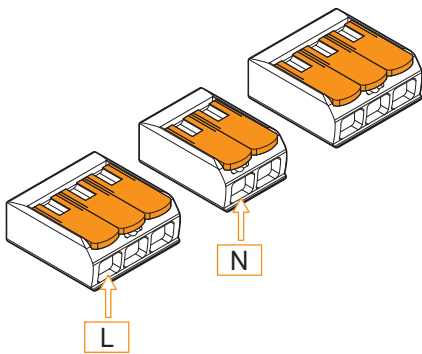

Morsetti a levetta liberi per alimentazione motore
Splicing connector with free-lever for the motor power source

Senso di rotazione orario
Clockwise direction of rotation

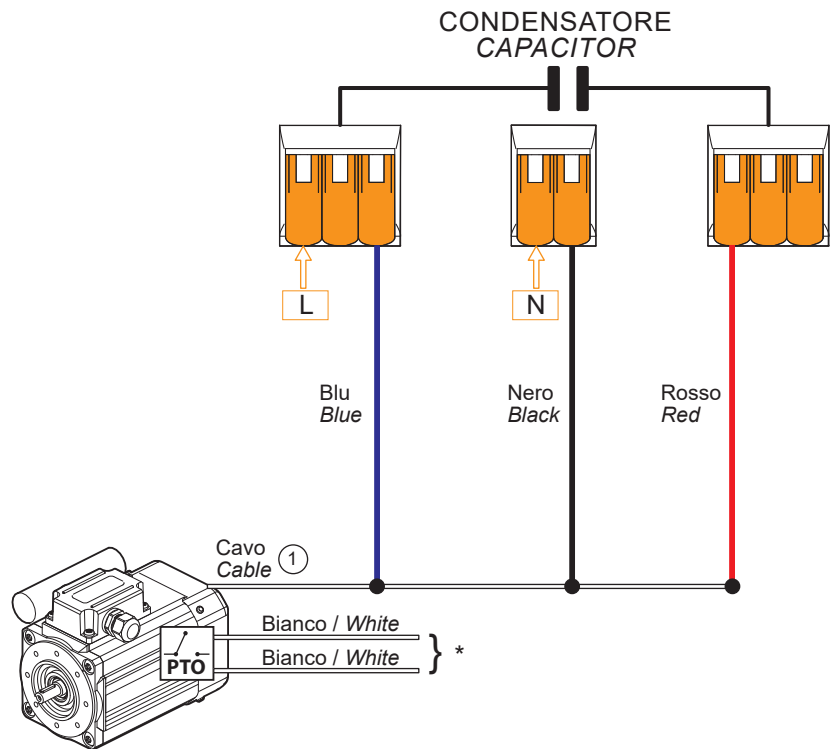
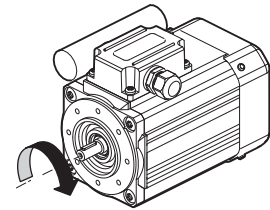

*: collegamento al circuito di comando del motore a cura del cliente. Per ragioni di sicurezza è sconsigliato il collegamento in serie. Se necessario contattare il Servizio Tecnico Transtecno. PTO disponibile per taglie 56, 63, 71

*: motor supply connection by the customer. For safety reason Transtecno advises against PTO connected in series. If needed, contact Transtecno Technical Service. PTO is available for sizes 56, 63, 71.

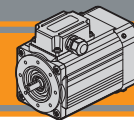

Connessioni e collegamenti

Connection diagram

230 V - Monofase / Single phase

Monofase da SMM 56... a SMM 71... / Single phase from SMM 56... to SMM 71...

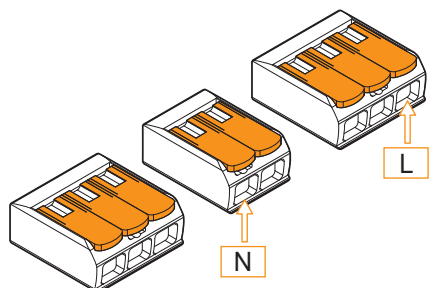

Morsetti a levetta liberi per alimentazione motore
Splicing connector with free-lever for the motor power source

Senso di rotazione antiorario
Counter-clockwise direction of rotation

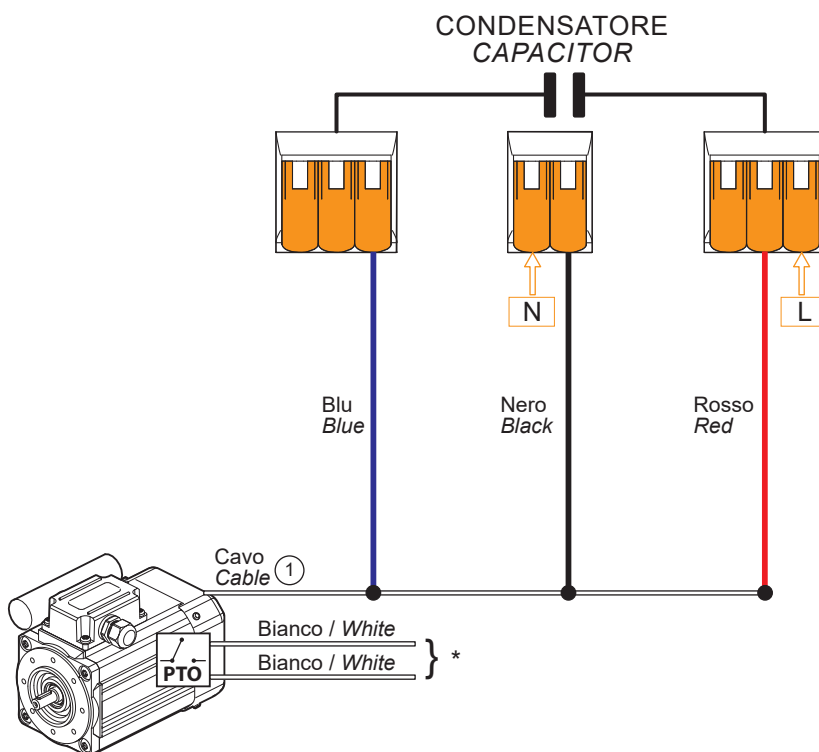
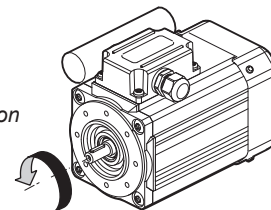

*: collegamento al circuito di comando del motore a cura del cliente. Per ragioni di sicurezza è sconsigliato il collegamento in serie. Se necessario contattare il Servizio Tecnico Transtecno. PTO disponibile per taglie 56, 63, 71

*: motor supply connection by the customer. For safety reason Transtecno advises against PTO connected in series. If needed, contact Transtecno Technical Service. PTO is available for sizes 56, 63, 71.

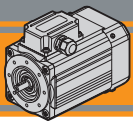

Targhetta

Nameplate

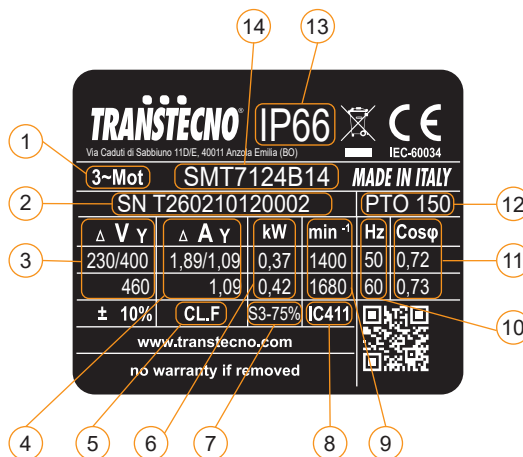

Pos.	Descrizione	Description
1	Tipo di alimentazione	Power supply
2	Numero di serie	Serial number
3	Tensione di alimentazione	Supply voltage
4	Corrente nominale	Rated current
5	Classe di isolamento	Insulation class
6	Potenza nominale	Rated power
7	Servizio	Duty
8	Ventilazione	Fan cooling
9	Velocità nominale	Rated speed
10	Frequenza nominale	Rated frequency
11	Fattore di potenza	Power factor
12	Protezione termica PTO 150°C	PTO 150°C Thermal protection
13	Grado di protezione IP	IP protection rating
14	Tipo motore	Motor type

MINI  **TECNO**™
small but strong

SM..BR



Motori elettrici CA autofrenanti
AC electric motors with brake



MINI  **TECNO**™ brand of
TRANSTECNO®



AC

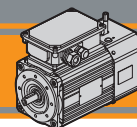

BRAKE

Indice	Index	Pag. Page
Caratteristiche tecniche	<i>Technical features</i>	AB2
Designazione	<i>Classification</i>	AB2
Simbologia e formule	<i>Symbols and formulas</i>	AB3
Dati tecnici	<i>Technical data</i>	AB3
Dimensioni motori trifase	<i>Three phase motors dimensions</i>	AB4
Cava esagonale	<i>Hexagonal socket</i>	AB5
Opzione guarnizione CA	<i>Rubber gasket option</i>	AB5
Gradi di protezione IP	<i>IP protection rating</i>	AB6
Tipo di servizio IEC	<i>IEC duty cycles</i>	AB7
Classe di isolamento termico	<i>Insulation class</i>	AB7
Tabella pressacavi	<i>Table of cable glands data</i>	AB7
Connessioni e collegamenti	<i>Connection diagram</i>	AB8
Targhetta	<i>Nameplate</i>	AB9

Questa sezione annulla e sostituisce ogni precedente edizione o revisione. Qualora questa sezione non Vi sia giunta in distribuzione controllata, l'aggiornamento dei dati ivi contenuto non è assicurato. **In tal caso la versione più aggiornata è disponibile sul nostro sito internet www.transtecno.com**

This section replaces any previous edition and revision. If you obtained this catalogue other than through controlled distribution channels, the most up to date content is not guaranteed. In this case the latest version is available on our web site www.transtecno.com

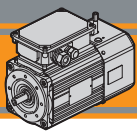

Caratteristiche tecniche

Technical characteristics

I motori autofrenanti delle serie SMT..BR hanno le seguenti caratteristiche principali:

SMT..BR braked motor range has the following main features:

- Costruzione compatta
- Motorizzazioni in corrente alternata trifase
- Carcasa estrusa in alluminio anodizzato nero
- Motore elettrico AC con grado di protezione IP66 (freno IP66 e IP65)
- Rumorosità e vibrazioni contenute
- Isolamento termico di classe F
- Flangia motore IEC B14
- Temperatura ambiente: 0°C / + 40°C (Per utilizzo a temperature diverse contattare il ns. servizio tecnico)
- Disponibili nella versione ventilata TEFC (servizio S1)
- Protezioni termiche PTO 150°C
- Adatti al funzionamento con alimentazione da inverter (Richiedere opzione freno con alimentazione separata)
- Cava esagonale su albero motore lato NDE.
- La tolleranza di tensione è ±10% per tutti i motori
- Il freno è a corrente continua

- *Compact design*
- *AC three phase motors available*
- *Black anodized extruded aluminium housing*
- *AC electric motor in IP66 protection Standard (IP66 and IP65 brake)*
- *Low noise and vibrations*
- *Class F insulation Standard*
- *Motor flange IEC B14*
- *Ambient temperature: 0°C / +40°C (For different temperatures contact Transtecno Technical Dept)*
- *Fan cooled TEFC (duty S1) available*
- *PTO 150°C thermal protection*
- *Suitable for running with frequency converter (Request brake option with separate power supply)*
- *Motor shaft hexagon socket on the NDE side*
- *The voltage tolerance is ±10% for all motors*
- *The brake is DC*

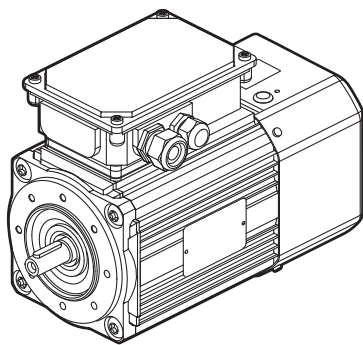

SMT..TEFC BR

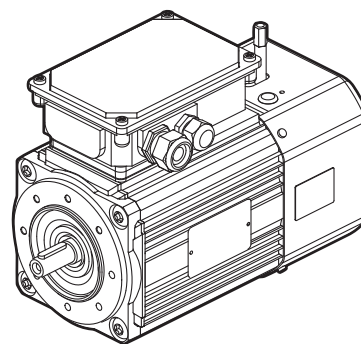

SMT..TEFC BRL



Designazione

Classification

MOTORE TRIFASE AUTOFRENANTE / THREE PHASE BRAKED MOTOR									
SMT	63	2	4	0.18 kW	B14	230-400 V	50 Hz	TEFC	BR
Tipo Type	Grandezza Size	Indicativo potenza Power coefficient	Poli Poles	Potenza Power	Forma costruttiva Version	Tensione Voltage	Frequenza Frequency	Ventilazione Fan cooling	Freno - Leva di sblocco Brake - Hand-release lever
SMT	Vedi tabelle See tables	1-2-3-4-5	4	0.18 kW ... 0.55 kW	B14	230-400 V 460V a richiesta on request	50Hz 60Hz	TEFC	BR BRL

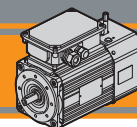

Simbologia e formule

Symbols and formulas

P_n	[kW]	Potenza nominale	Rated power
I_n	[A]	Corrente nominale (a 400V)	Rated current (at 400V)
M_n	[Nm]	Coppia nominale	Rated torque
n_n	[rpm]	Velocità nominale	Rated speed
M_s / M_n		Rapporto coppia spunto / coppia nominale	Ratio start torque / rated torque
M_k / M_n		Rapporto coppia massima / coppia nominale	Ratio max torque / rated torque
M_b	[Nm]	Coppia frenante	Braking torque
I_s / I_n		Rapporto corrente di spunto / corrente nominale	Ratio start current / rated current
$\cos\phi$		Fattore di potenza al carico nominale	Power factor at rated torque load
η		Rendimento al carico nominale	Efficiency at rated torque load
Potenza Power	[HP]	Potenza [kW] x 1.341	Power [kW] x 1.341
Potenza resa P_n P_n output power	[kW]	Potenza assorbita x η	Absorbed power x η
Pot. assorbita Absorbed power	[kW]	$\frac{\sqrt{x} \cdot I \cdot \cos\phi}{1000}$ (monofase)	$\frac{\sqrt{x} \cdot I \cdot \cos\phi}{1000}$ (singlephase)
		$\frac{\sqrt{x} \cdot I \cdot \sqrt{3} \cdot \cos\phi}{1000}$ (trifase)	$\frac{\sqrt{x} \cdot I \cdot \sqrt{3} \cdot \cos\phi}{1000}$ (threephase)
I_n (230 V)		I_n (400 V) x $\sqrt{3}$	I_n (400 V) x $\sqrt{3}$

Dati tecnici

Technical data

SMT..BR Motori trifase autofrenanti / SMT..BR Three phase motors with brake (230-400 V / 50 Hz) poli / poles 4

TAGLIA SIZE	P_n [kW]	M_n [Nm]	n_n [min ⁻¹]	I_n (400V) [A]	η %	$\cos\phi$	M_s/M_n	I_s/I_n	M_k/M_n	PTO [°C]	Servizio Duty TEFC	IP Motore Motor	M_b [Nm]	IP Freno Brake
SMT6324B14BR(L)	0.18	1.26	1360	0.69	57.0	0.66	2.50	2.90	2.50	PTO 150°	S3 75%	66	4	66
SMT6334B14BR(L)	0.25	1.74	1375	0.94	62.0	0.64	2.80	3.00	2.80				4	66
SMT7124B14BR(L)	0.37	2.52	1400	1.10	67.9	0.72	2.75	4.20	2.75				7,5	65
SMT7134B14BR(L)	0.55	3.76	1395	1.55	70.2	0.73	2.90	4.40	2.90				7,5	65

I freni adottati sono freni elettromagnetici ad azione negativa: l'azione frenante viene quindi esercitata in assenza di alimentazione.

Il freno è a corrente continua e, in configurazione standard, viene alimentato direttamente da una fase del motore, passando attraverso un raddrizzatore alloggiato all'interno della morsetteria. Per le applicazioni in cui si rende necessario, come ad esempio l'azionamento tramite inverter, è possibile richiedere l'alimentazione del freno separata 230Vac ±10% 50Hz. Sono disponibili anche le versioni 400Vac ±10% 50Hz o 24Vdc.

La leva di sblocco è una opzione che va specificata in fase di ordine.

The brakes adopted are negative action electromagnetic brakes: the braking action is performed in the absence of power.

The brake is DC and, in standard configuration, is powered directly by a phase of the motor, passing through a rectifier housed inside the terminal block. For the applications in which it is required, like the ones with motor driven by inverter, it is possible to request 230Vac ± 10% 50Hz separate brake power supply. 400Vac ± 10% 50Hz or 24Vdc power supply are available on request.

The release lever is an option that must be requested when ordering.

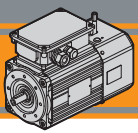

Dimensioni motori trifase

Three phase motors dimensions

3~

SMT63.. - B14 - TEFC - BR (L)

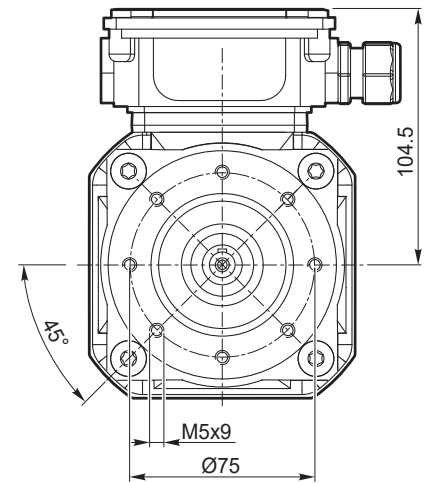
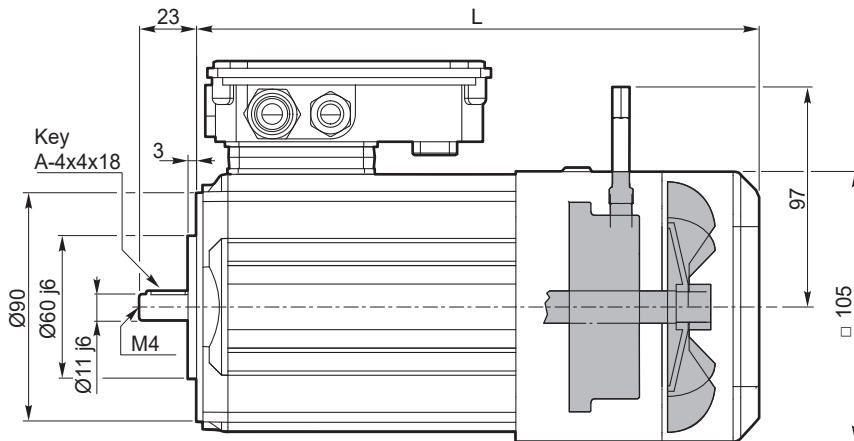

Nota:

La leva di sblocco è una opzione che va specificata in fase di ordine.

Note:

The release lever is an option that must be requested when ordering.

SMT..BR	... TEFC	
	L	Kg
6324	211	5.8
6334	226	6.5

3~

SMT71.. - B14 - TEFC - BR (L)

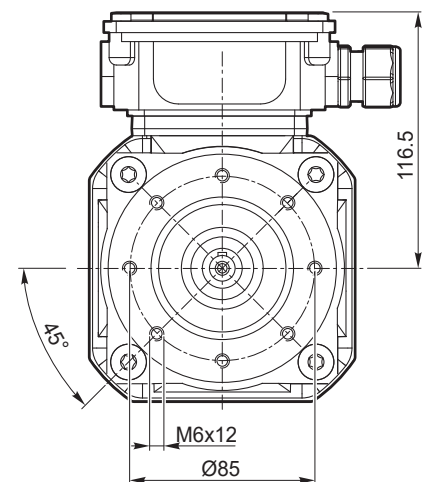
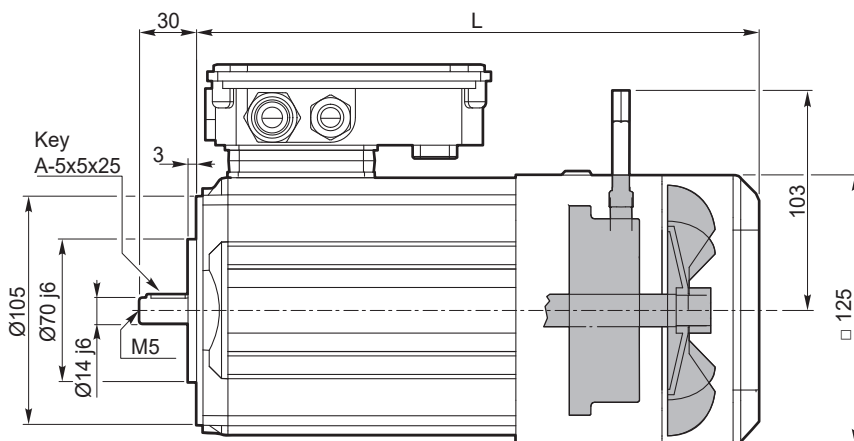

Nota:

La leva di sblocco è una opzione che va specificata in fase di ordine.

Note:

The release lever is an option that must be requested when ordering.

SMT..BR	... TEFC	
	L	Kg
7124	221	7.8
7134	236	8.9

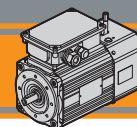

Cava esagonale

Hexagonal socket

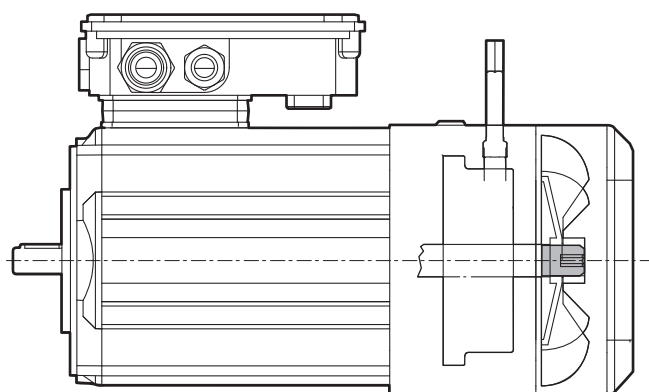

Esagono / Hexagon

SM..	E
63	4
71	6

Nota:

Installare a monte dell'alimentazione un dispositivo che assicuri la disconnessione della rete omipolare, durante le operazioni di rotazione manuale è obbligatorio l'utilizzo di tale sezionatore.

Il quadro elettrico del motore deve essere lucchettabile al fine di evitare il riarmo non previsto alla rete elettrica.

E' severamente vietata la messa in servizio del motore elettrico senza copriventola opportunamente montata.

Note:

An omnipolar cut-off device must be fitted upstream of the power supply; the use of this device is mandatory during manual rotation operations.

The switchgear for the motor must be padlockable in order to prevent the power supply from being accidentally reset. It is strictly prohibited to put the electric motor into service if the fan cover is not fitted.

AC

Opzione guarnizione CA

Rubber gasket option

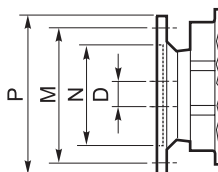
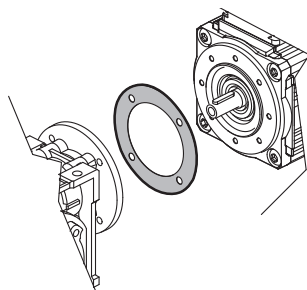

Dimensioni IEC / IEC Dimensions

	63 B14	71 B14
N	60	70
M	75	85
P	90	105
D	11	14

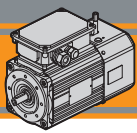

Grado di protezione IP

IP protection rating

Indica il grado di isolamento meccanico del corpo motore.









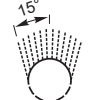

1^a cifra protezione alla penetrazione di corpi solidi.

2^a cifra protezione contro la penetrazione d'acqua.

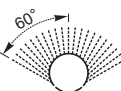
IP protection rating indicates the degree of mechanical insulation of the motor casing.

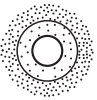
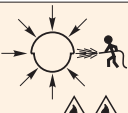
The 1st figure indicates the level of protection against the intrusion of solid matter.

The 2nd figure indicates to which degree the motor is waterproof.

IP		Definizione / Description	IP		Definizione / Description
0		Non protetto / No protection	0		Non protetto / No protection
1		Protetto da corpi solidi superiori a Ø 50 mm. <i>Protected against solid matter (over Ø 50 mm).</i>	1		Protetto contro la caduta verticale di gocce d'acqua. <i>Protected against drops of water falling vertically.</i>
2		Protetto da corpi solidi superiori a Ø 12 mm. <i>Protected against solid matter (over Ø 12 mm).</i>	2		Protetto contro la caduta verticale di gocce d'acqua con inclinazione max di 15°. <i>Protected against drops of water falling up to 15°.</i>
3		Protetto da corpi solidi superiori a Ø 2.5 mm. <i>Protected against solid matter (over Ø 2.5 mm).</i>	3		Protetto contro la pioggia. <i>Rain proof.</i>
4		Protetto da corpi solidi superiori a Ø1 mm. <i>Protected against solid matter (over Ø1 mm).</i>	4		Protetto contro gli spruzzi. <i>Splash proof.</i>
5		Protetto contro la polvere. <i>Dust protected.</i>	5		Protetto contro getti d'acqua. <i>Water jet proof.</i>
6		Totalmente protetto contro la polvere. <i>Fully dust tight.</i>	6		Protetto dalle ondate. <i>Waveproof.</i>
7	N.A.	N.A.	7		Protetto contro immersione. <i>Immersion up to 1 metre.</i>
8	N.A.	N.A.	8		Protetto contro immersione/sommersione prolungata. <i>Immersion beyond 1 metre.</i>

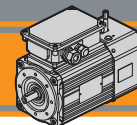

Tipi di servizi IEC

IEC duty cycles

Il servizio di un motore indica il tipo di utilizzo e la gravosità del ciclo di lavoro.

The duty cycle of a motor indicates its use and running cycle.

Grafico servizi più comuni

Most common duty cycles diagram

N = funzionamento / run
R = riposo / rest

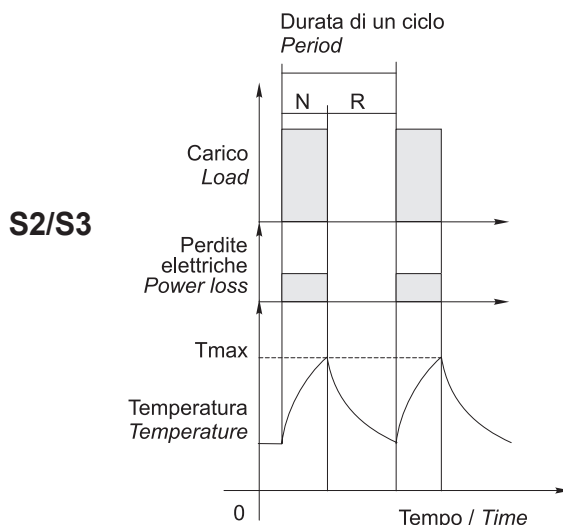
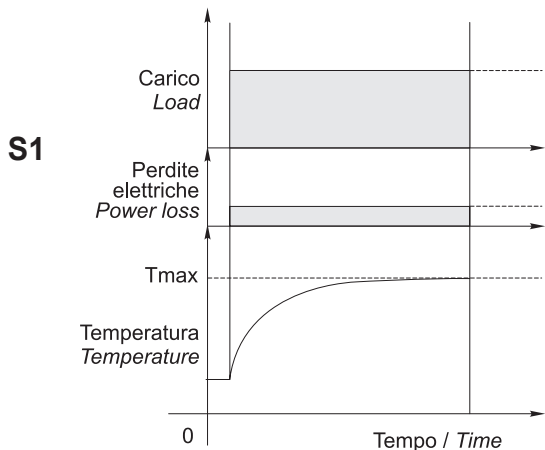

NOTA: Lo stesso motore può essere usato per cicli e servizi diversi, con l'unica limitazione che la temperatura interna non superi mai la Tmax stabilita dalla classe di isolamento termico del motore.

NOTE: The same motor can run under all duty services, limitation is due to internal temperature that must not override Tmax stated by motor thermal class.

Classe di isolamento termico

Insulation class

La classe termica indica il grado di resistenza alla temperatura interna, nel punto più caldo (avvolgimenti). Isolamento termico classe F.

Thermal insulation class indicates the level of thermal protection measured at the hottest point inside the motor (windings). Thermal insulation class F.

Classe Class	Massima temperatura interna Max. windings temp.
E	120°C
B	130°C
F	155°C
H	180°C



Tabella pressacavi

Table of cable glands data

Serie SM..BR / SM..BR Series

TAGLIA SIZE	Pressacavo Cable gland
63 / 71	1x M20x1.5

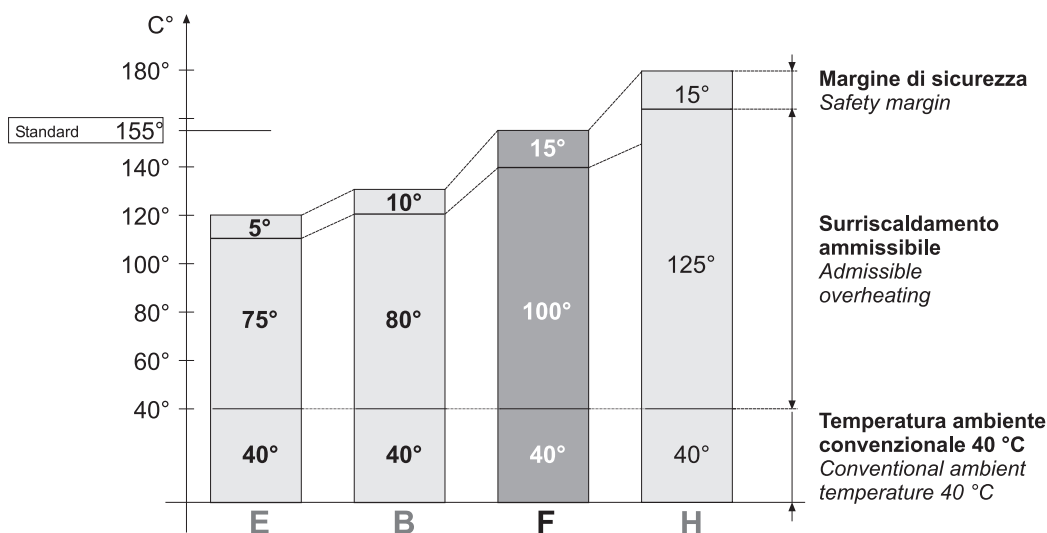
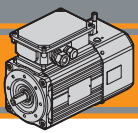

Connessioni e collegamenti

Connection diagram

Riferimenti

References

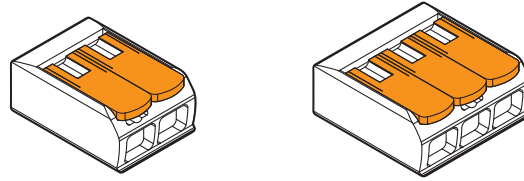

Morsetto di collegamento a leva a 2 e 3 poli
Splicing connector with lever 2 - and 3 - pin.

400/460 V - Trifase / three phase

Collegamento a stella / Star connection

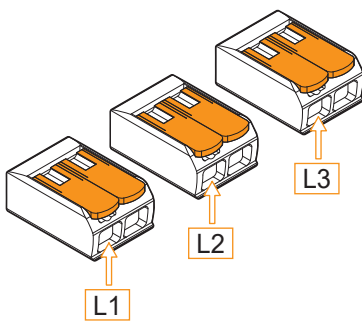

Morsetti a levetta liberi per alimentazione motore
Splicing connector with free-lever for the motor power source

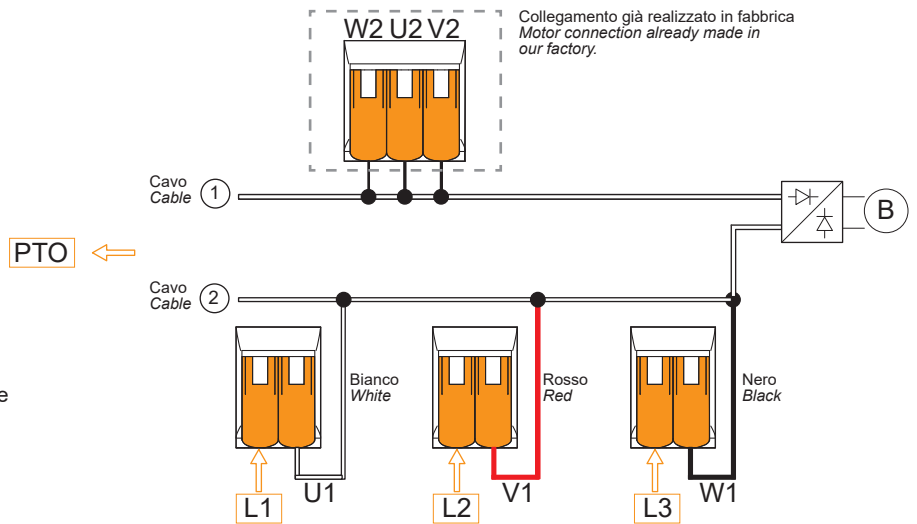

230 V - Trifase / three phase

Collegamento a triangolo / Delta connection

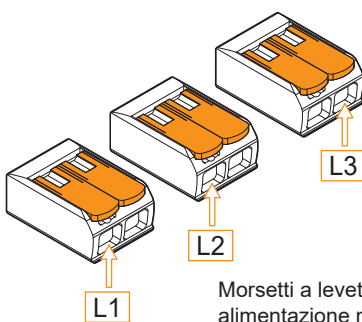

Morsetti a levetta liberi per alimentazione motore

Splicing connector with free-lever for the motor power source

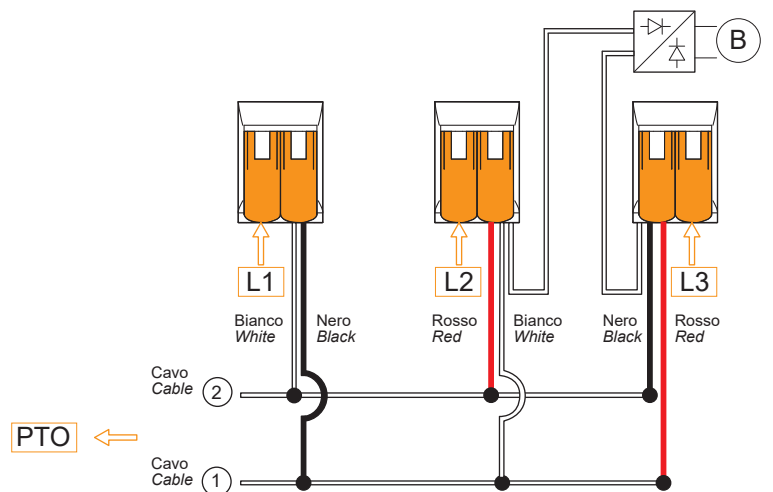

I motori della serie SM sono forniti in collegamento a stella, lo schema di collegamento a triangolo sopra riportato fornisce una chiara indicazione delle modifiche che il cliente può apportare in autonomia. Se necessario contattare il Servizio Tecnico Transtecno.

The SM series is supplied in star connection, the delta connection diagram shown above provides a clear indication of the modification that the customer can make independently. If needed, contact Transtecno Technical Service.

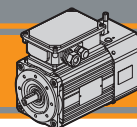

Targhetta

Nameplate

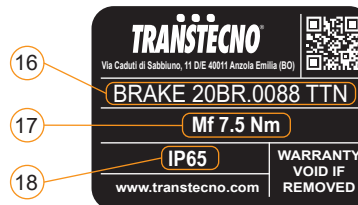
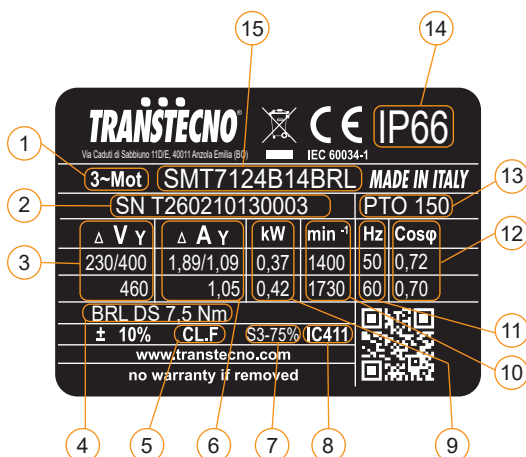

Pos.	Descrizione	Description
1	Tipo di alimentazione	Power supply
2	Numero di serie	Serial number
3	Tensione di alimentazione	Supply voltage
4	Tipo freno	Brake type
5	Classe di isolamento	Insulation class
6	Corrente nominale	Rated current
7	Servizio	Duty
8	Ventilazione	Fan cooling
9	Potenza nominale	Rated power
10	Velocità nominale	Rated speed
11	Frequenza nominale	Rated frequency
12	Fattore di potenza	Power factor
13	Protezione termica PTO 150°C	PTO 150°C Thermal protection
14	Grado di protezione IP motore	Motor IP protection rating
15	Tipo motore	Motor type
16	Codice freno	Brake code
17	Coppia frenante	Braking torque
18	Grado di protezione IP freno	Brake IP protection rating

MINI  **TECNO**™
small but strong

SM..SV



Motori elettrici CA servoventilati
AC electric motors with forced-ventilation



MINI  **TECNO**™ brand of
TRANSTECNO®



AC

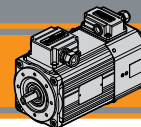

Indice	Index	Pag. Page
Caratteristiche tecniche	<i>Technical features</i>	AC2
Designazione	<i>Classification</i>	AC2
Simbologia e formule	<i>Symbols and formulas</i>	AC3
Dati tecnici	<i>Technical data</i>	AC3
Dimensioni motori trifase	<i>Three phase motors dimensions</i>	AC4
Opzione guarnizione CA	<i>Rubber gasket option</i>	AC5
Gradi di protezione IP	<i>IP protection rating</i>	AC5
Tipo di servizio IEC	<i>IEC duty cycles</i>	AC6
Classe di isolamento termico	<i>Insulation class</i>	AC6
Serie SM - Funzionamento a 60 Hz	<i>Series SM - 60 Hz line power supply</i>	AC7
Tabella pressacavi	<i>Table of cable glands data</i>	AC7
Connessioni e collegamenti - Motore	<i>Connection diagram - Motor</i>	AC7
Connessioni e collegamenti - Servoventola	<i>Connection diagram - Servo fan</i>	AC9
Targhetta	<i>Nameplate</i>	AC10

Questa sezione annulla e sostituisce ogni precedente edizione o revisione. Qualora questa sezione non Vi sia giunta in distribuzione controllata, l'aggiornamento dei dati ivi contenuto non è assicurato. **In tal caso la versione più aggiornata è disponibile sul nostro sito internet www.transtecno.com**

This section replaces any previous edition and revision. If you obtained this catalogue other than through controlled distribution channels, the most up to date content is not guaranteed. In this case the latest version is available on our web site www.transtecno.com

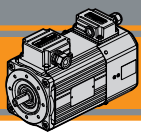

Caratteristiche tecniche

Technical characteristics

I motori della serie SMT..SV hanno le seguenti caratteristiche principali:

SMT..SV motor range has the following main features:

- Costruzione compatta
 - Motorizzazioni in corrente alternata trifase
 - Carcasa estrusa in alluminio anodizzato nero
 - Motore elettrico AC con grado di protezione IP 66 (solo motore - servoventola con grado di protezione IP44)
 - Rumorosità e vibrazioni contenute
 - Isolamento termico di classe F
 - Flangia motore IEC B14
 - Temperatura ambiente: 0°C / + 40°C (Per utilizzo a temperature diverse contattare il ns. servizio tecnico)
 - Protezioni termiche PTO 150°C
 - Adatti al funzionamento con alimentazione da inverter
 - La tolleranza di tensione è ±10% per tutti i motori
- Compact design
 - AC three phase motors available
 - Black anodized extruded aluminium housing
 - AC Electric motors with IP66 Protection standard (only motor - Servo fan with IP44 protection Standard)
 - Low noise and vibrations
 - Class F insulation Standard
 - Motor flange IEC B14
 - Ambient temperature: 0°C / +40°C (For different temperatures contact Transtecno Technical Dept)
 - PTO 150°C thermal protection
 - Suitable for running with frequency converter
 - The voltage tolerance is ±10% for all motors

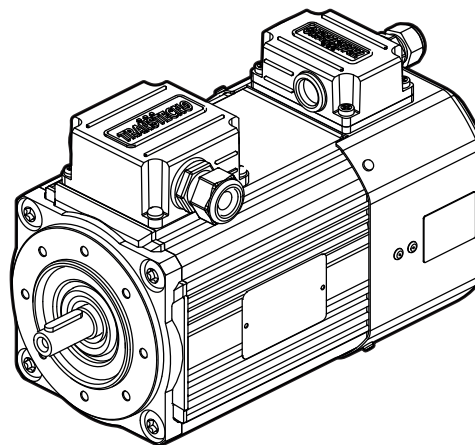



SMT..SV



Designazione

Classification

MOTORE TRIFASE SERVOVENTILATO / THREE PHASE MOTOR WITH FORCED-VENTIATION								
SMT	63	2	4	0.18 kW	B14	230-400 V	50 Hz	SV
Tipo Type	Grandezza Size	Indicativo potenza Power coefficient	Poli Poles	Potenza Power	Forma costruttiva Version	Tensione Voltage	Frequenza Frequency	Ventilazione Fan cooling
SMT	Vedi tabelle See tables	1-2-3-4-5	4	0.18 kW ... 0.75 kW	B14	230-400 V 460V a richiesta on request	50Hz 60Hz	SV
								
								

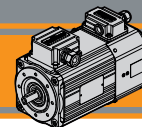

Simbologia e formule

Symbols and formulas

P_n	[kW]	Potenza nominale	Rated power
I_n	[A]	Corrente nominale (a 400V)	Rated current (at 400V)
M_n	[Nm]	Coppia nominale	Rated torque
n_n	[rpm]	Velocità nominale	Rated speed
M_s / M_n		Rapporto coppia spunto / coppia nominale	Ratio start torque / rated torque
M_k / M_n		Rapporto coppia massima / coppia nominale	Ratio max torque / rated torque
I_s / I_n		Rapporto corrente di spunto / corrente nominale	Ratio start current / rated current
$\cos\phi$		Fattore di potenza al carico nominale	Power factor at rated torque load
η		Rendimento al carico nominale	Efficiency at rated torque load
P_{sf}	[W]	Potenza assorbita servoventola	Electric fan power
Potenza Power	[HP]	Potenza [kW] x 1.341	Power [kW] x 1.341
Potenza resa P_n P_n output power	[kW]	Potenza assorbita x η	Absorbed power x η
Pot. assorbita Absorbed power	[kW]	$\frac{\sqrt{x} \cdot I \cdot \cos\phi}{1000}$ (monofase)	$\frac{\sqrt{x} \cdot I \cdot \cos\phi}{1000}$ (singlephase)
		$\frac{\sqrt{x} \cdot I \cdot \sqrt{3} \cdot \cos\phi}{1000}$ (trifase)	$\frac{\sqrt{x} \cdot I \cdot \sqrt{3} \cdot \cos\phi}{1000}$ (threephase)
I_n (230 V)		I_n (400 V) x $\sqrt{3}$	I_n (400 V) x $\sqrt{3}$

Dati tecnici

Technical data

SMT..SV Motori trifase servoventilati / SMT..SV Three phase motors with forced-ventilation (230-400 V / 50 Hz) poli / poles **4**

TAGLIA SIZE	P_n [kW]	M_n [Nm]	n_n [min ⁻¹]	I_n (400V) [A]	η %	$\cos\phi$	M_s/M_n	I_s/I_n	M_k/M_n	PTO [°C]	Servizio Duty SV	IP Motore Motor	IP Servoventola Foced vent.	P_{sf} [W]
SMT6324B14.SV	0.18	1.26	1360	0.69	57.0	0.66	2.50	2.90	2.50	PTO 150°	S3 75%	66	44	11-9
SMT6334B14.SV	0.25	1.74	1375	0.94	62.0	0.64	2.80	3.00	2.80				44	11-9
SMT6344B14.SV	0.37	2.60	1360	1.24	65.3	0.66	2.70	3.00	2.70				44	11-9
SMT7124B14.SV	0.37	2.52	1400	1.10	67.9	0.72	2.75	4.20	2.75				44	14-16
SMT7134B14.SV	0.55	3.76	1395	1.55	70.2	0.73	2.90	4.40	2.90				44	14-16
SMT7144B14.SV	0.75	5.09	1405	2.00	74.0	0.73	2.90	5.00	2.90				44	14-16

Alimentazione della servoventola: 200-240 Vac / 50-60 Hz

Forced ventilation supply voltage: 200-240 Vac / 50-60 Hz

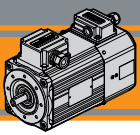

Dimensioni motori trifase

Three phase motors dimensions

3 ~

SMT63.. - B14 - SV

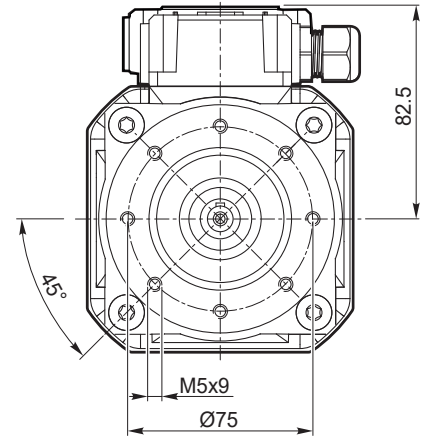
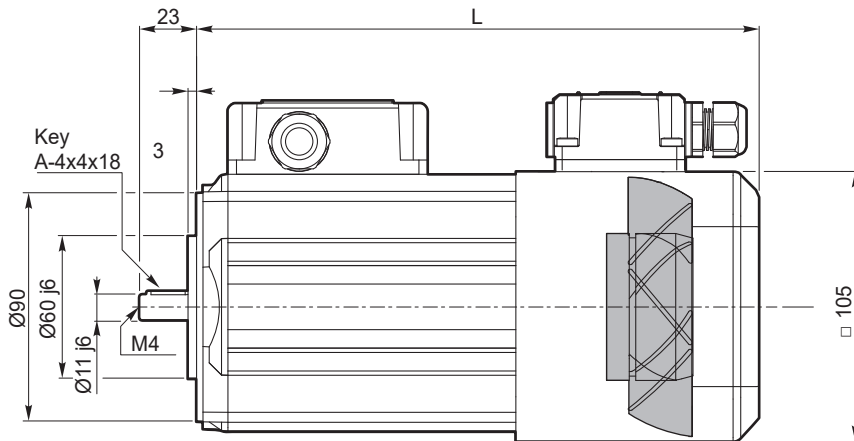

SMT	... SV	
	L	Kg
6324	210	5.0
6334	225	5.7
6344	250	6.8

3 ~

SMT71.. - B14 - SV

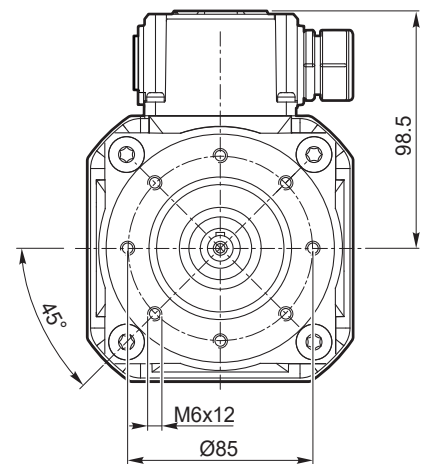
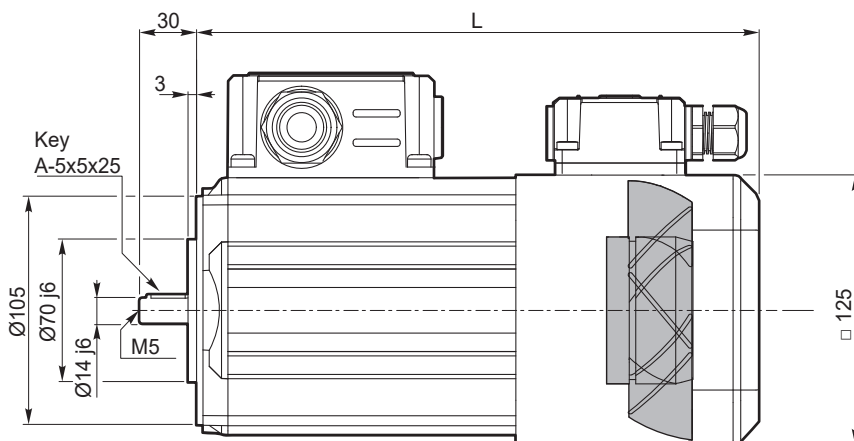

SMT	... SV	
	L	Kg
7124	219	7.5
7134	234	8.5
7144	259	10.2

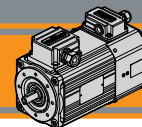

Opzione guarnizione CA

Rubber gasket option

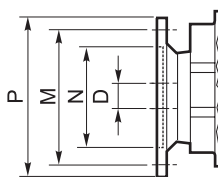
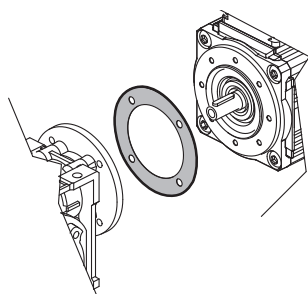

Dimensioni IEC / IEC Dimensions		
	63 B14	71 B14
N	60	70
M	75	85
P	90	105
D	11	14

Grado di protezione IP

IP protection rating

Indica il grado di isolamento meccanico del corpo motore.

IP protection rating indicates the degree of mechanical insulation of the motor casing.

1^a cifra protezione alla penetrazione di corpi solidi.

The 1st figure indicates the level of protection against the intrusion of solid matter.

2^a cifra protezione contro la penetrazione d'acqua.

The 2nd figure indicates to which degree the motor is waterproof.

IP		Definizione / Description	IP		Definizione / Description
0		Non protetto / No protection	0		Non protetto / No protection
1		Protetto da corpi solidi superiori a Ø 50 mm. Protected against solid matter (over Ø 50 mm).	1		Protetto contro la caduta verticale di gocce d'acqua. Protected against drops of water falling vertically.
2		Protetto da corpi solidi superiori a Ø 12 mm. Protected against solid matter (over Ø 12 mm).	2		Protetto contro la caduta verticale di gocce d'acqua con inclinazione max di 15°. Protected against drops of water falling up to 15°.
3		Protetto da corpi solidi superiori a Ø 2.5 mm. Protected against solid matter (over Ø 2.5 mm).	3		Protetto contro la pioggia. Rain proof.
4		Protetto da corpi solidi superiori a Ø 1 mm. Protected against solid matter (over Ø 1 mm).	4		Protetto contro gli spruzzi. Splash proof.
5		Protetto contro la polvere. Dust protected.	5		Protetto contro getti d'acqua. Water jet proof.
6		Totalmente protetto contro la polvere. Fully dust tight.	6		Protetto dalle ondate. Waveproof.
7		N.A.	7		Protetto contro immersione. Immersion up to 1 metre.
8		N.A.	8		Protetto contro immersione/sommersione prolungata. Immersion beyond 1 metre.

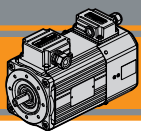

Tipi di servizi IEC

IEC duty cycles

Il servizio di un motore indica il tipo di utilizzo e la gravosità del ciclo di lavoro.

The duty cycle of a motor indicates its use and running cycle.

Grafico servizi più comuni

Most common duty cycles diagram

N = funzionamento / run
R = riposo / rest

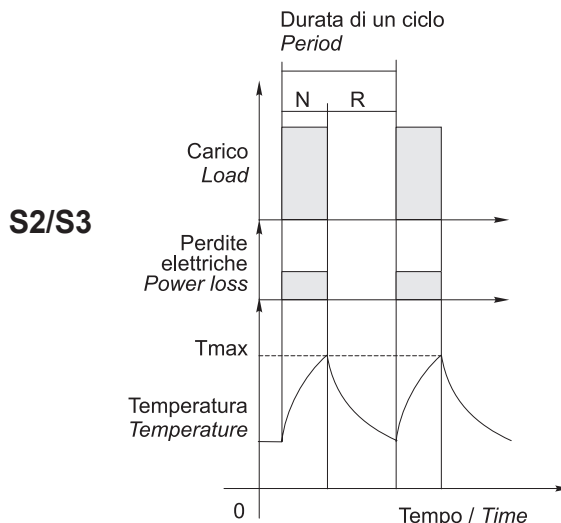
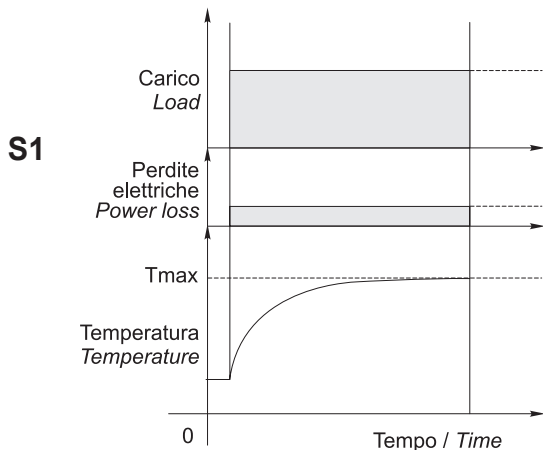

NOTA: Lo stesso motore può essere usato per cicli e servizi diversi, con l'unica limitazione che la temperatura interna non superi mai la Tmax stabilita dalla classe di isolamento termico del motore.

NOTE: The same motor can run under all duty services, limitation is due to internal temperature that must not override Tmax stated by motor thermal class.

Classe di isolamento termico

Insulation class

La classe termica indica il grado di resistenza alla temperatura interna, nel punto più caldo (avvolgimenti). Isolamento termico classe F.

Thermal insulation class indicates the level of thermal protection measured at the hottest point inside the motor (windings). Thermal insulation class F.

Classe Class	Massima temperatura interna Max. windings temp.
E	120°C
B	130°C
F	155°C
H	180°C

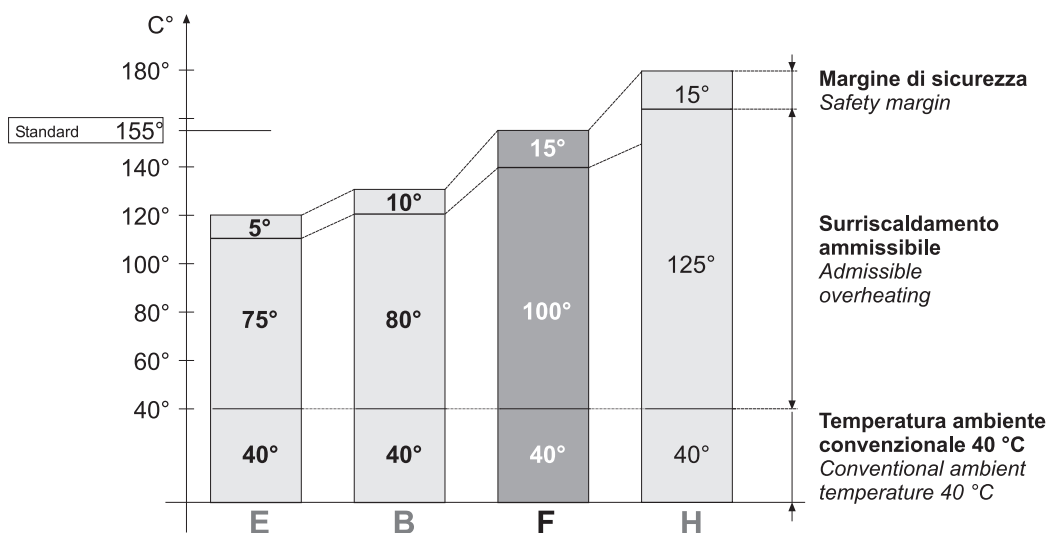

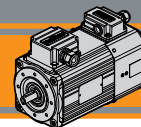

Serie SM - Funzionamento a 60 Hz

Series SM - 60 Hz line power supply

Velocità, coppia e potenza nominale nel funzionamento a 60 Hz varieranno come da tabella:

Speed, torque and rated power in 60 Hz operation is shown in the following table:

	50 Hz	60 Hz
400 V	Vedi dati tecnici / see technical data 	Velocità / speed $\approx + 20\%$ Coppia / torque $\approx -20\%$ Potenza / power \approx invariata / the same
480 V	Non permesso / not allowed	Velocità / speed $\approx + 20\%$ Coppia / torque \approx invariata / the same Potenza / power $\approx + 20\%$

AC

Tabella pressacavi

Table of cable glands data

Serie SM..BR / SM..BR Series

TAGLIA SIZE	Pressacavo Cable gland
63 / 71	1x M20x1.5

Connessioni e collegamenti - Motore

Connection diagram - Motor

Riferimenti

References

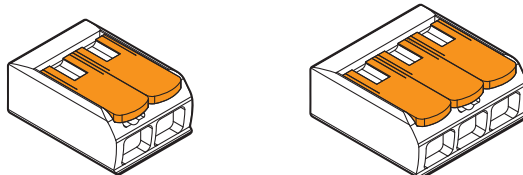

Morsetto di collegamento a leva a 2 e 3 poli
Splicing connector with lever 2 - and 3 - pin.

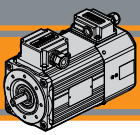

Connessioni e collegamenti - Motore

Connection diagram - Motor

400/460 V - Trifase / three phase

Collegamento a stella / Star connection

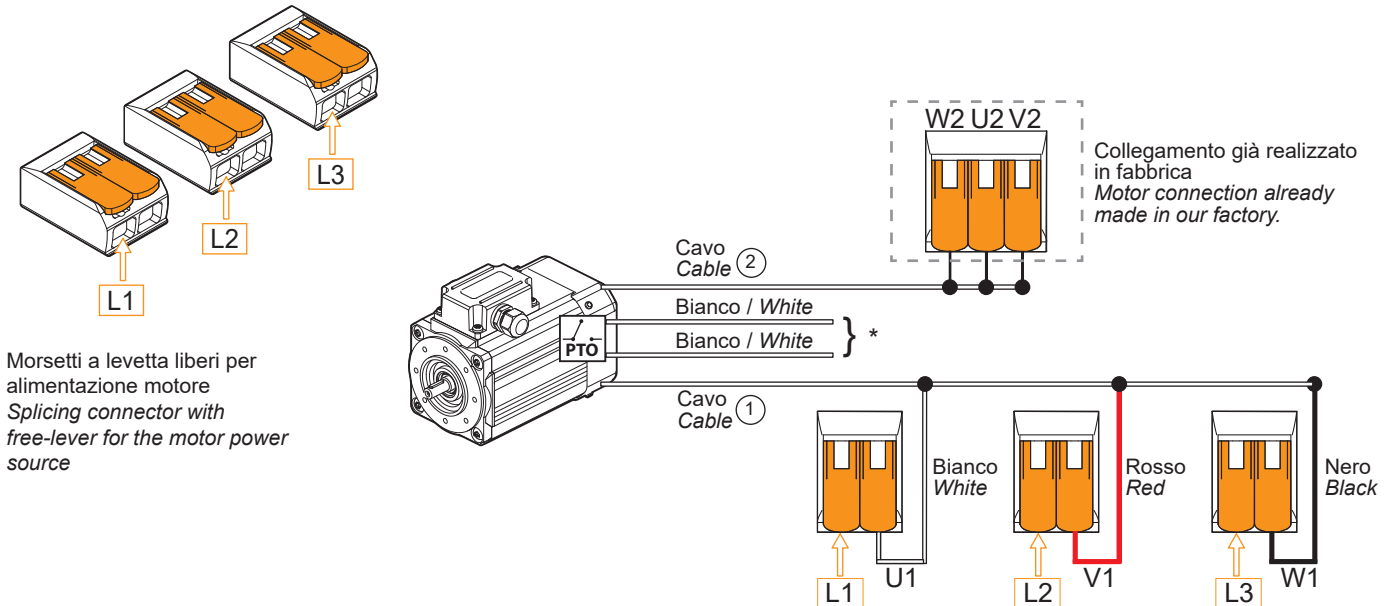

*: collegamento al circuito di comando del motore a cura del cliente. Per ragioni di sicurezza è sconsigliato il collegamento in serie. Se necessario contattare il Servizio Tecnico Transtecno. PTO disponibile per taglie 56, 63, 71, 80, 90.

*: motor supply connection by the customer. For safety reason Transtecno advises against PTO connected in series. If needed, contact Transtecno Technical Service. PTO is available for sizes 56, 63, 71, 80, 90.

230 V - Trifase / three phase

Collegamento a triangolo / Delta connection

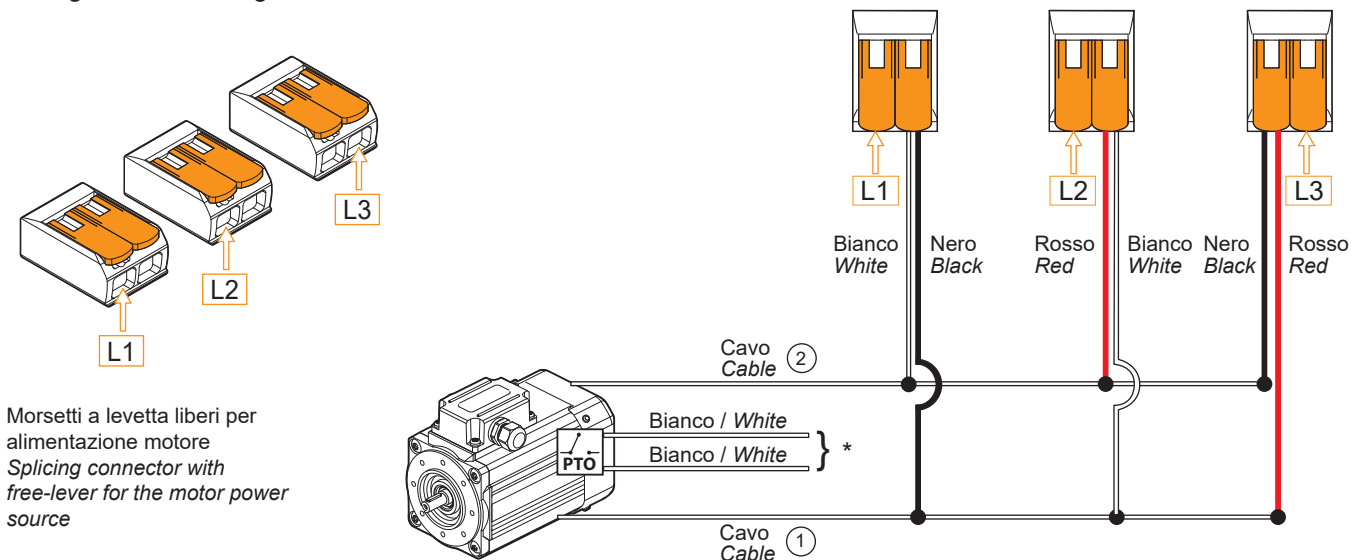

*: collegamento al circuito di comando del motore a cura del cliente. Per ragioni di sicurezza è sconsigliato il collegamento in serie. Se necessario contattare il Servizio Tecnico Transtecno. PTO disponibile per taglie 56, 63, 71, 80, 90.

*: motor supply connection by the customer. For safety reason Transtecno advises against PTO connected in series. If needed, contact Transtecno Technical Service. PTO is available for sizes 56, 63, 71, 80, 90.

I motori della serie SM sono forniti in collegamento a stella, lo schema di collegamento a triangolo sopra riportato fornisce una chiara indicazione delle modifiche che il cliente può apportare in autonomia. Se necessario contattare il Servizio Tecnico Transtecno.

The SM series is supplied in star connection, the delta connection diagram shown above provides a clear indication of the modification that the customer can make independently. If needed, contact Transtecno Technical Service.

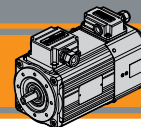

Connessioni e collegamenti - Servoventola

Connection diagram - Servo fan

Riferimenti

References

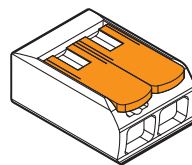
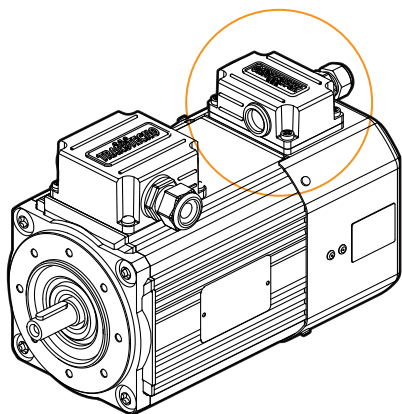

Morsetto di collegamento a leva a 2 poli
Splicing connector with lever 2 pin.

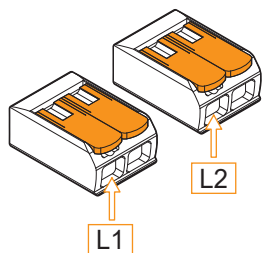

Morsetti a levetta liberi per alimentazione servoventola
Splicing connector with free-lever for the electric fan

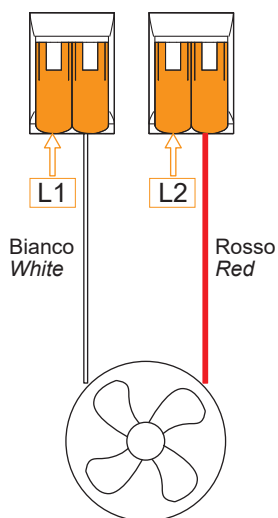

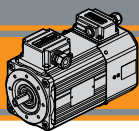

Targhetta

Nameplate

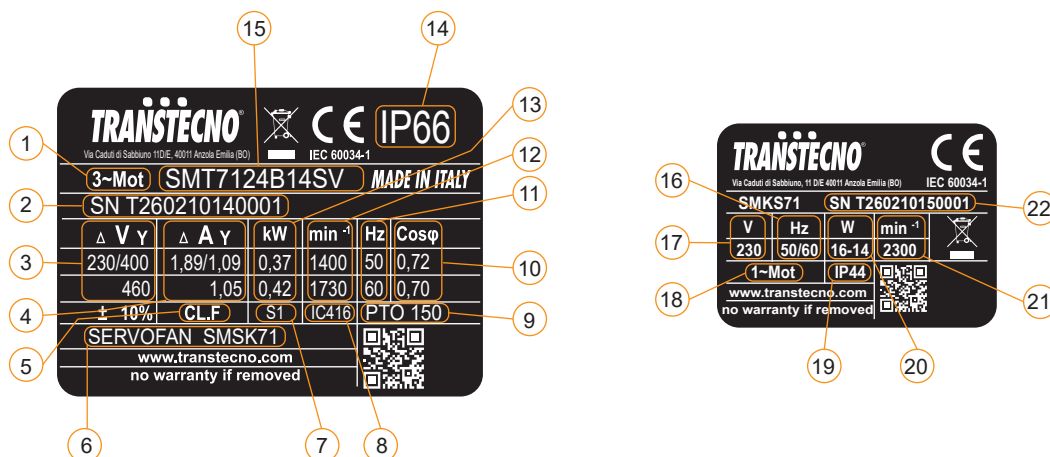

Pos.	Descrizione	Description
1	Tipo di alimentazione	Power supply
2	Numero di serie	Serial number
3	Tensione di alimentazione	Supply voltage
4	Corrente nominale	Rated current
5	Classe di isolamento	Insulation class
6	Tipo servoventola	Servo fan type
7	Servizio	Duty
8	Ventilazione	Fan cooling
9	Protezione termica PTO 150°C	PTO 150°C Thermal protection
10	Fattore di potenza	Power factor
11	Frequenza nominale	Rated frequency
12	Velocità nominale	Rated speed
13	Potenza nominale	Rated power
14	Grado di protezione IP motore	Motor IP protection rating
15	Tipo motore	Motor type
16	Frequenza kit servoventola	Servo fan kit frequency
17	Tensione kit servoventola	Servo fan kit voltage
18	Tipo di alimentazione kit servoventola	Servo fan kit power supply
19	Grado di protezione kit servoventola	Servo fan kit IP protection rating
20	Potenza kit servoventola	Servo fan kit power
21	Velocità kit servoventola	Servo fan kit speed
22	Numero di serie kit servoventola	Servo fan kit serial number

MINI  TM
TECNO
small but strong

SM..UL/CSA



Motori elettrici asincroni CA
AC asynchronous electric motors

C  **US**
File E511911



MINI  TM
TECNO brand of
TRANSTECNO[®]



AC

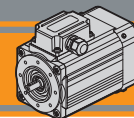

Indice	Index	Pag. Page
Caratteristiche tecniche	<i>Technical features</i>	AD2
Designazione	<i>Classification</i>	AD2
Simbologia e formule	<i>Symbols and formulas</i>	AD3
Dati tecnici	<i>Technical data</i>	AD3
Dimensioni motori trifase	<i>Three phase motors dimensions</i>	AD4
Dimensioni motori monofase	<i>Single phase motors dimensions</i>	AD7
Cava esagonale	<i>Hexagonal socket</i>	AD8
Versioni opzionali	<i>Optional versions</i>	AD8
Opzione guarnizione CA	<i>Rubber gasket option</i>	AD8
Certificazione UL / CSA	<i>UL / CSA certificate</i>	AD8
Gradi di protezione IP	<i>IP protection rating</i>	AD9
Tipo di servizio IEC	<i>IEC duty cycles</i>	AD10
Tabella pressacavi	<i>Table of cable glands data</i>	AD10
Connessioni e collegamenti	<i>Connection diagram</i>	AD11
Targhetta	<i>Nameplate</i>	AD13

Questa sezione annulla e sostituisce ogni precedente edizione o revisione. Qualora questa sezione non Vi sia giunta in distribuzione controllata, l'aggiornamento dei dati ivi contenuto non è assicurato. **In tal caso la versione più aggiornata è disponibile sul nostro sito internet www.transtecno.com**

This section replaces any previous edition and revision. If you obtained this catalogue other than through controlled distribution channels, the most up to date content is not guaranteed. In this case the latest version is available on our web site www.transtecno.com

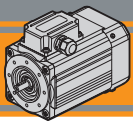

Caratteristiche tecniche

Technical characteristics

I motori certificati UL/CSA delle serie SMT ed SMM hanno le seguenti caratteristiche principali:

SMT and SMM motor range with UL/CSA Certification has the following main features:

- Costruzione compatta
- Motorizzazioni in corrente alternata monofase e trifase
- Carcasa estrusa in alluminio anodizzato nero
- Motore elettrico AC con grado di protezione IP66 (escluso condensatore)
- Rumorosità e vibrazioni contenute
- Isolamento termico di classe F
- Flangia motore IEC B14
- Temperatura ambiente: -20°C/+40°C
- Disponibili nella versione ventilata TEFC (servizio S1).
- Protezione termica PTO 150°C
- Motori trifase SMT dotati di separatori di fase
- Cava esagonale su albero motore lato NDE
- Condensatore di marcia per motori monofase SMM
- La tolleranza di tensione è ±10%
- Standard applicati:
UL1004-1: Rotating Electrical Machines General Requirements
CSA:100-14: Motors and Generators

- Compact design
- AC single phase and three phase motors available
- Black anodized extruded aluminium housing
- AC electric motor in IP66 protection Standard (except capacitor)
- Low noise and vibrations
- Class F insulation Standard
- Motor flange IEC B14
- Ambient temperature: -20°C / +40°C
- Fan cooled TEFC (duty S1)
- PTO 150°C thermal protection
- Three phase motors SMT equipped with phase separators.
- Motor shaft hexagon socket on the NDE side.
- Running capacitor for single phase motors SMM.
- Voltage tolerance ±10%
- Standards applied:
UL1004-1: Rotating Electrical Machines General Requirements
CSA:100-14: Motors and Generators

SM .. TEFC

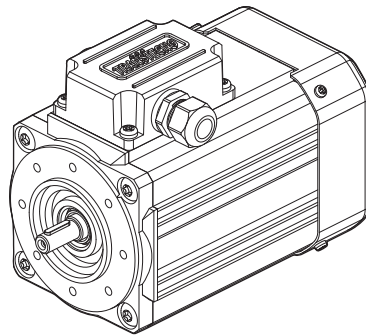



CU US
File E511911



Designazione

Classification

MOTORE TRIFASE / THREE PHASE MOTOR									
SMT	63	2	4	0.18 kW	B14	230-400 V	50 Hz	TEFC	UL-CSA
Tipo Type	Grandezza Size	Indicativo potenza Power coefficient	Poli Poles	Potenza Power	Forma costruttiva Version	Tensione Voltage	Frequenza Frequency	Ventilazione Fan cooling	Versione UL UL Version
SMT  3 ~	Vedi tabelle See tables	2 - 3	4	0.09 kW ... 0.66 kW	B14	230-400 V 460V	50Hz 60Hz	TEFC	UL-CSA

MOTORE MONOFASE / SINGLE PHASE MOTOR									
SMM	63	2	4	0.18 kW	B14	115 V	60 Hz	TEFC	UL-CSA
Tipo Type	Grandezza Size	Indicativo potenza Power coefficient	Poli Poles	Potenza Power	Forma costruttiva Version	Tensione Voltage	Frequenza Frequency	Ventilazione Fan cooling	Versione UL UL Version
SMM  1 ~	Vedi tabelle See tables	2 - 3	4	0.09 kW ... 0.37 kW	B14	115V	60Hz	TEFC	UL-CSA

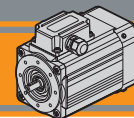
Simbologia e formule
Symbols and formulas

P_n	[kW]	Potenza nominale	Rated power
I_n	[A]	Corrente nominale	Rated current
M_n	[Nm]	Coppia nominale	Rated torque
n_n	[rpm]	Velocità nominale	Rated speed
M_s / M_n		Rapporto coppia spunto / coppia nominale	Ratio start torque / rated torque
M_k / M_n		Rapporto coppia massima / coppia nominale	Ratio max torque / rated torque
I_s / I_n		Rapporto corrente di spunto / corrente nominale	Ratio start current / rated current
$\cos\varphi$		Fattore di potenza al carico nominale	Power factor at rated torque load
η		Rendimento al carico nominale	Efficiency at rated torque load
f	[Hz]	Frequenza	Frequency
V	[V]	Tensione	Voltage
Potenza Power	[HP]	Potenza [kW] x 1.341	Power [kW] x 1.341
Potenza resa P_n P_n output power	[kW]	Potenza assorbita x η	Absorbed power x η
Pot. assorbita Absorbed power	[kW]	$\frac{V \times I \times \cos\varphi}{1000}$ (monofase)	$\frac{V \times I \times \cos\varphi}{1000}$ (singlephase)
		$\frac{V \times I \times \sqrt{3} \times \cos\varphi}{1000}$ (trifase)	$\frac{V \times I \times \sqrt{3} \times \cos\varphi}{1000}$ (threephase)
I_n (230 V)		I_n (400 V) x $\sqrt{3}$	I_n (400 V) x $\sqrt{3}$

Dati tecnici
Technical data
SMT Motori trifase / SMT Three phase motors

 (230-400 V / 50 Hz) poli / poles **4**

 (460 V / 60 Hz) poli / poles **4**

TAGLIA SIZE	P_n [kW]	M_n [Nm]	n_n [min ⁻¹]	V - f [V - Hz]	I_n (400-460 V) [A]	η %	$\cos\varphi$	M_s/M_n	I_s/I_n	M_k/M_n	PTO [°C]	Servizio Duty TEFC
5624	0.09	0.63	1365	400 - 50	0.45	47.3	0.61	2.50	2.40	2.70	PTO 150°	S1
	0.11		1660	460 - 60		50.3		2.60	2.60			
5634	0.12	0.88	1300	400 - 50	0.45	52.0	0.74	1.90	2.40	1.90		
	0.14	0.83	1600	460 - 60	0.42	59.0	0.71	2.10	2.70	2.10		
6324	0.18	1.26	1360	400 - 50	0.69	57.0	0.66	2.50	2.90	2.50		
	0.22	1.27	1650	460 - 60		59.7	0.67		3.00			
6334	0.25	1.74	1375	400 - 50	0.94	62.0	0.64	2.80	3.00	2.80		
	0.28	1.59	1690	460 - 60		61.3	0.61	3.00	3.20	3.00		
7124	0.37	2.52	1400	400 - 50	1.09	68.0	0.72	2.75	4.20	2.75		
	0.42	2.35	1700	460 - 60		68.1	0.71	2.90	4.50	2.90		
7134	0.55	3.76	1395	400 - 50	1.55	70.2	0.73	2.90	4.40	2.90		
	0.66	3.71	1700	460 - 60		73.2			4.80	2.80		

SMM Motori monofase / SMM Single phase motors

 (115 V / 60 Hz) poli / poles **4**

TAGLIA SIZE	P_n [kW]	M_n [Nm]	n_n [min ⁻¹]	V - f [V - Hz]	I_n (115V) [A]	η %	$\cos\varphi$	M_s/M_n	I_s/I_n	M_k/M_n	Cond/cap [μF]	PTO [°C]	Servizio Duty TEFC
5624	0.09	0.52	1665	115 - 60	1.60	50.0	0.98	0.64	1.95	1.51	20	PTO 150°	S1
6324	0.18	1.09	1570	115 - 60	2.70	58.5	0.99	1.0	2.1	1.50	40		
7124	0.37	2.18	1620	115 - 60	4.70	69.8	0.98	0.64	2.3	1.33	60		

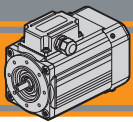

Dimensioni motori trifase

Three phase motors dimensions

3~

SMT56.. - B14 - TEFC

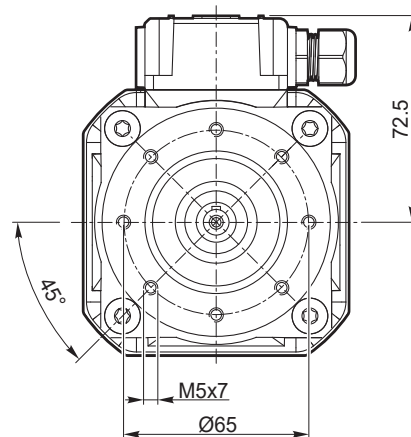
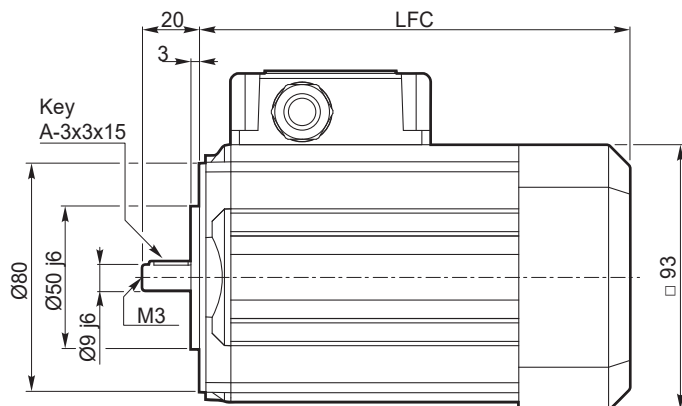

SMT	... TEFC	
	LFC	Kg
5624	186	3.1
5634	186	3.5

3~

SMT63.. - B14 - TEFC

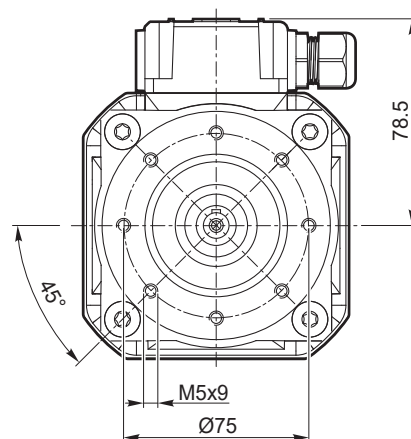
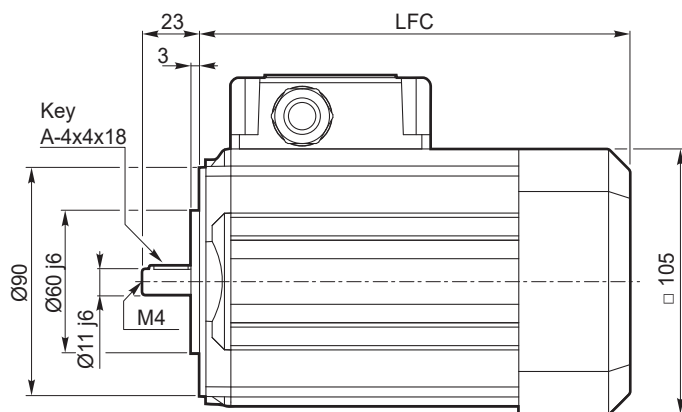

SMT	... TEFC	
	LFC	Kg
6324	205.5	4.7
6334	205.5	5.4

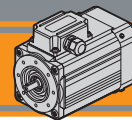



Dimensioni motori trifase

Three phase motors dimensions

3 ~

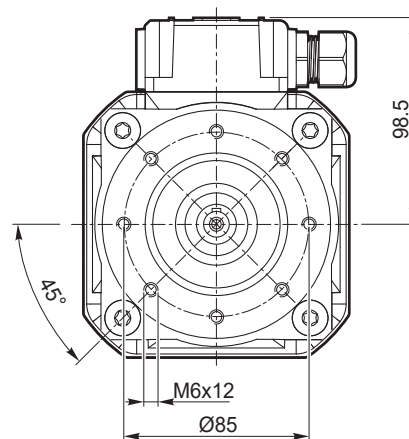
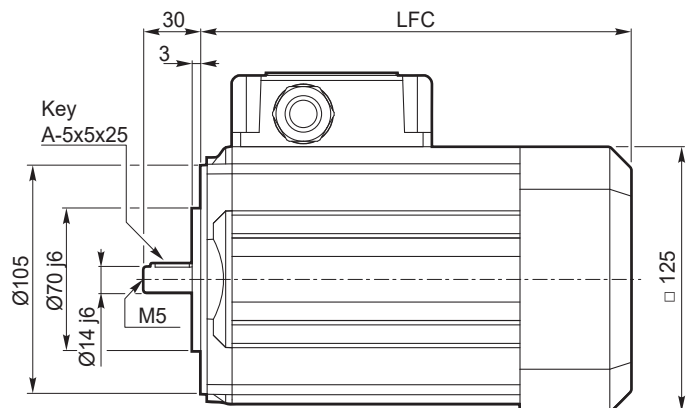
SMT71.. - B14 - TEFC



SMT	... TEFC	
	LFC	 Kg
7124	214	7.0
7134	214	8.2

AC

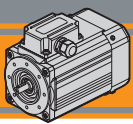

Dimensioni motori monofase

Single phase motors dimensions

1 ~

SMM56.. - B14 - TEFC

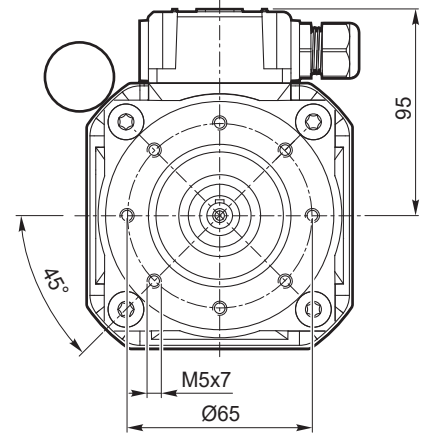
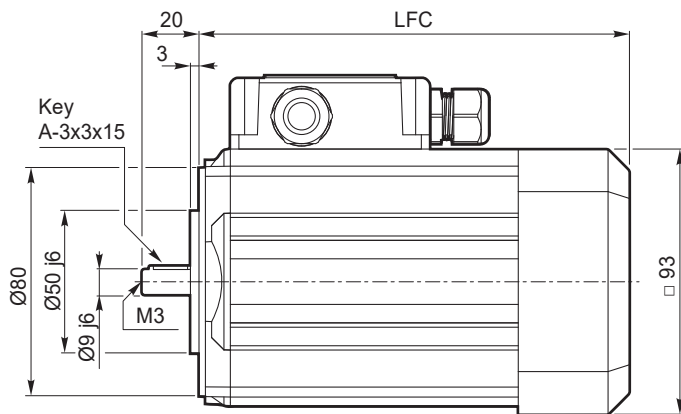

SMM	... TEFC	
	LFC	Kg
5624	186	3.6

1 ~

SMM63.. - B14 - TEFC

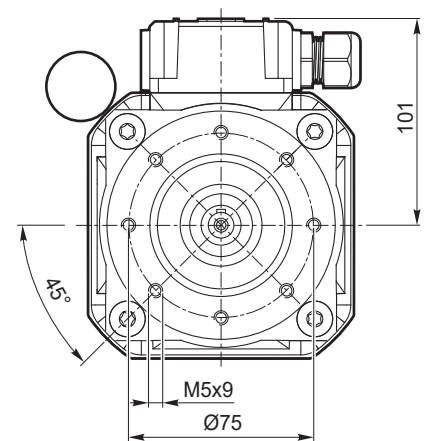
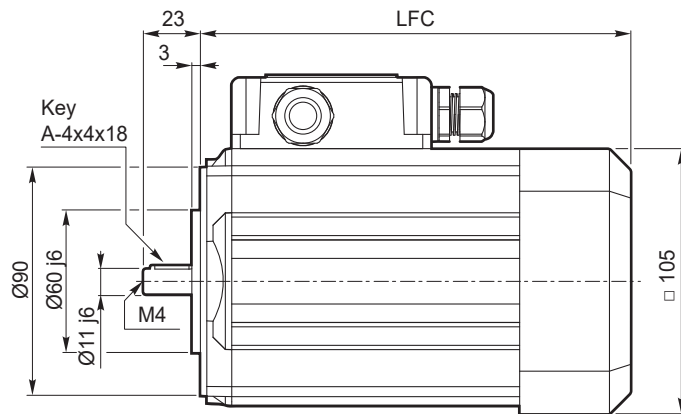

SMM	... TEFC	
	LFC	Kg
6324	205.5	5.5

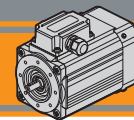

Dimensioni motori monofase

Single phase motors dimensions

1 ~

SMM71.. - B14 - TEFC

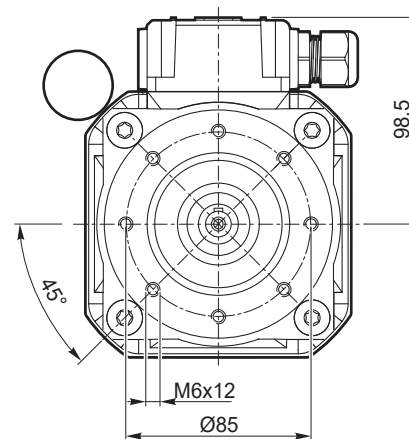
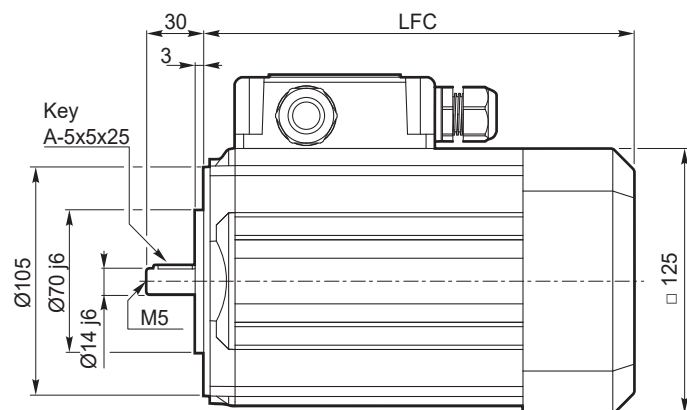

SMM	... TEFC	
	LFC	kg
7124	214	8.0

AC

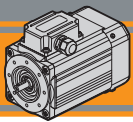

Cava esagonale

Hexagonal socket

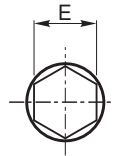
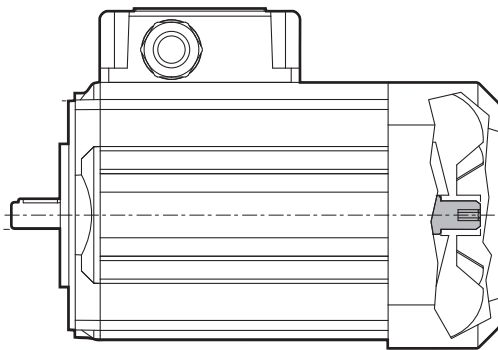

Esagono / Hexagon

SM..	E
56	4
63	4
71	6

Nota:

Installare a monte dell'alimentazione un dispositivo che assicuri la disconnessione della rete omipolare, durante le operazioni di rotazione manuale è obbligatorio l'utilizzo di tale sezionatore.

Il quadro elettrico del motore deve essere lucchettabile al fine di evitare il riarmo non previsto alla rete elettrica.

E' severamente vietata la messa in servizio del motore elettrico senza copriventola opportunamente montata.

Note:

An omnipolar cut-off device must be fitted upstream of the power supply; the use of this device is mandatory during manual rotation operations.

The switchgear for the motor must be padlockable in order to prevent the power supply from being accidentally reset. It is strictly prohibited to put the electric motor into service if the fan cover is not fitted.

Opzione guarnizione CA

Rubber gasket option

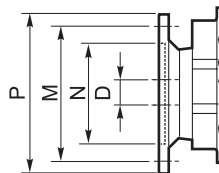
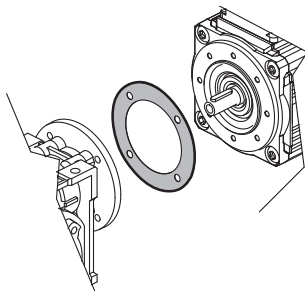

Dimensioni IEC / IEC Dimensions

	56 B14	63 B14	71 B14
N	50	60	70
M	65	75	85
P	80	90	105
D	9	11	14

Versioni opzionali

Optional versions

Versioni opzionali con freno ed encoder disponibili a richiesta su alcuni modelli. Su richiesta sono disponibili grandezze motore superiori a quelle indicate a catalogo.

Si prega di contattare il nostro Servizio Tecnico.

Optional versions with brake and encoder are available on request on some models. Motor sizes bigger than those indicated in the catalogue are available on request.

Please contact our Technical Service.

Certificazione UL / CSA

UL / CSA certificate

I motori SM certificati UL/CSA sono marcati secondo la Norma UL 1004-1, Rotating Electrical Machines General Requirements e CSA 100-14, Motors and Generators.

SM motors Certified UL/CSA are marked for approval by UL 1004-1, Rotating Electrical Machines General Requirements and CSA 100-14, Motors and Generators.

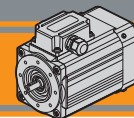
Grado di protezione IP
IP protection rating

Indica il grado di isolamento meccanico del corpo motore.

1^a cifra protezione alla penetrazione di corpi solidi.

2^a cifra protezione contro la penetrazione d'acqua.

IP protection rating indicates the degree of mechanical insulation of the motor casing.

The 1st figure indicates the level of protection against the intrusion of solid matter.

The 2nd figure indicates to which degree the motor is waterproof.

IP		Definizione / Description	IP		Definizione / Description
0		Non protetto / No protection	0		Non protetto / No protection
1		Protetto da corpi solidi superiori a Ø 50 mm. Protected against solid matter (over Ø 50 mm).	1		Protetto contro la caduta verticale di gocce d'acqua. Protected against drops of water falling vertically.
2		Protetto da corpi solidi superiori a Ø 12 mm. Protected against solid matter (over Ø 12 mm).	2		Protetto contro la caduta verticale di gocce d'acqua con inclinazione max di 15°. Protected against drops of water falling up to 15°.
3		Protetto da corpi solidi superiori a Ø 2.5 mm. Protected against solid matter (over Ø 2.5 mm).	3		Protetto contro la pioggia. Rain proof.
4		Protetto da corpi solidi superiori a Ø 1 mm. Protected against solid matter (over Ø 1 mm).	4		Protetto contro gli spruzzi. Splash proof.
5		Protetto contro la polvere. Dust protected.	5		Protetto contro getti d'acqua. Water jet proof.
6		Totalmente protetto contro la polvere. Fully dust tight.	6		Protetto dalle ondate. Waveproof.
7		N.A.	7		Protetto contro immersione. Immersion up to 1 metre.
8		N.A.	8		Protetto contro immersione/sommersione prolungata. Immersion beyond 1 metre.

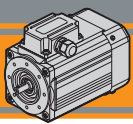

Tipi di servizi IEC

IEC duty cycles

Il servizio di un motore indica il tipo di utilizzo e la gravosità del ciclo di lavoro.

The duty cycle of a motor indicates its use and running cycle.

Grafico servizi più comuni

Most common duty cycles diagram

N = funzionamento / run
R = riposo / rest

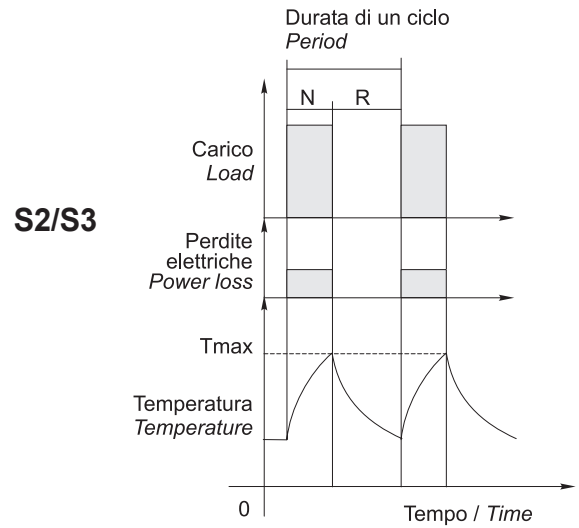
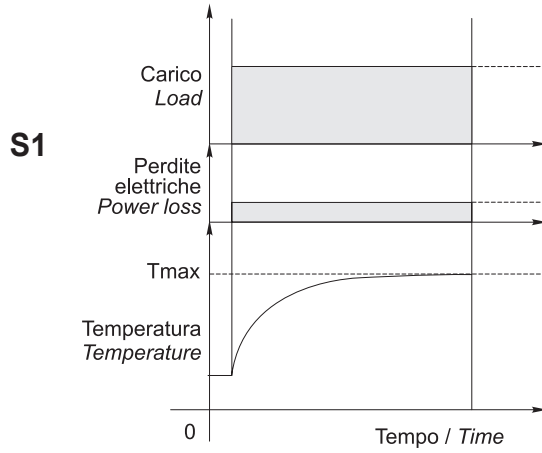

NOTA: Lo stesso motore può essere usato per cicli e servizi diversi, con l'unica limitazione che la temperatura interna non superi mai la T_{max} stabilita dalla classe di isolamento termico del motore.

NOTE: The same motor can run under all duty services, limitation is due to internal temperature that must not override T_{max} stated by motor thermal class.

Tabella pressacavi

Table of cable glands data

Serie SMT / SMT Series

TAGLIA SIZE	Pressacavo Cable gland
56 / 63	M16x1.5
71	M20x1.5

Serie SMM / SMM Series

TAGLIA SIZE	Pressacavo Cable gland
56 / 63	2 x M16x1.5
71	1x M20x1.5 + 1 x M16x1.5

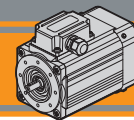

Connessioni e collegamenti

Connection diagram

Riferimenti

References

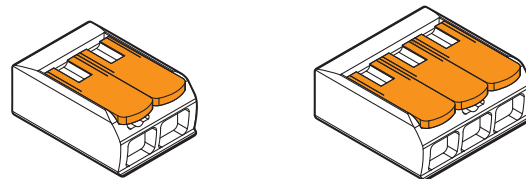
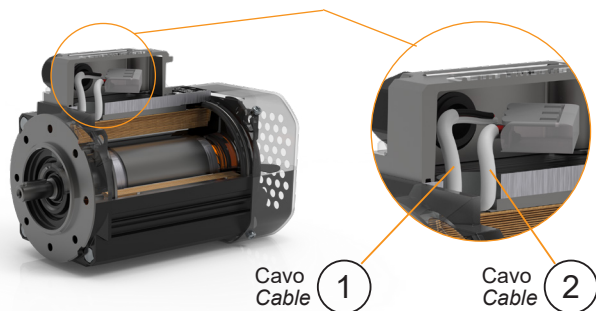

Morsetto di collegamento a leva a 2 e 3 poli
Splicing connector with lever 2- and 3-pin.

400/460 V - Trifase / three phase

Collegamento a stella / Star connection

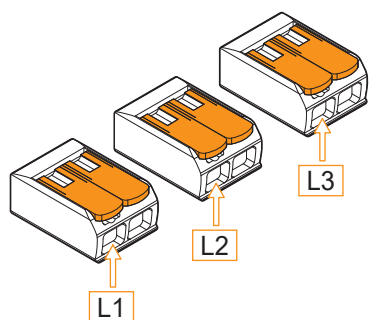

Morsetti a levetta liberi per alimentazione motore
Splicing connector with free-lever for the motor power source

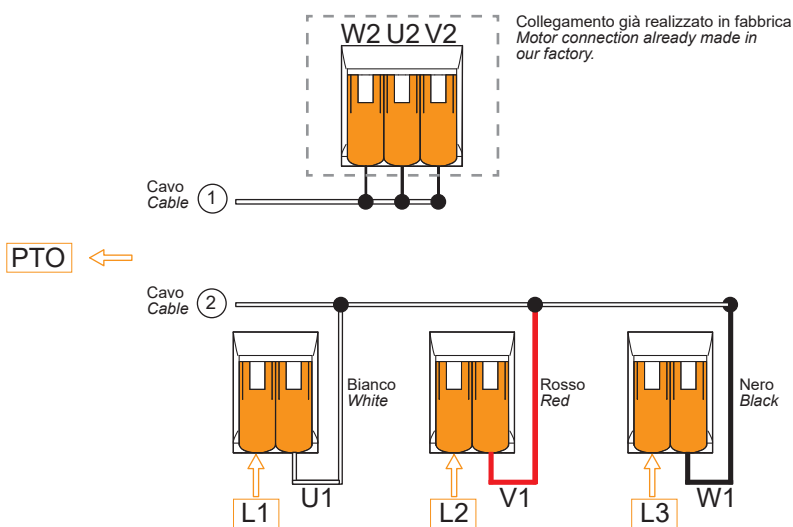

230 V - Trifase / three phase

Collegamento a triangolo / Delta connection

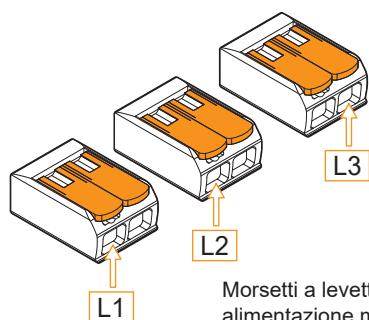

Morsetti a levetta liberi per alimentazione motore

Splicing connector with free-lever for the motor power source

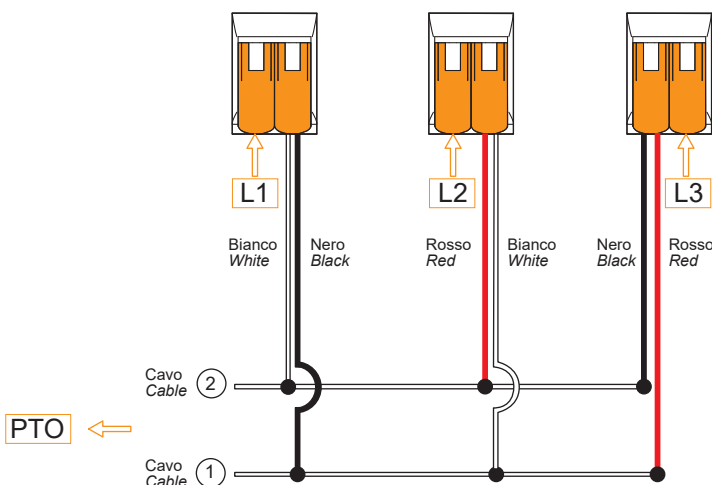

I motori della serie SM sono forniti in collegamento a stella, lo schema di collegamento a triangolo sopra riportato fornisce una chiara indicazione delle modifiche che il cliente può apportare in autonomia. Senecessario contattare il Serziao Tecnico Transtecno.

The SM series is supplied in star connection, the delta connection diagram shown above provides a clear indication of the modification that the customer can make independently. If needed, contact Transtecno Technical Service.

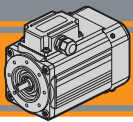

Connessioni e collegamenti

Connection diagram

115 V - Monofase / single phase

Monofase da SMM 56... a SMM 71... / Single phase from SMM 56... to SMM 71...

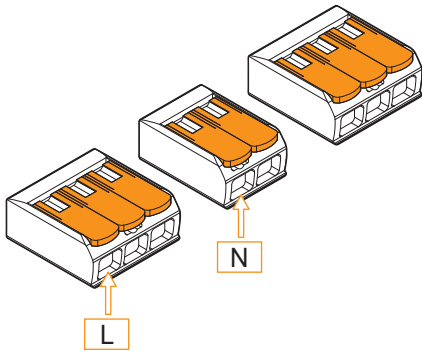

Morsetti a levetta liberi per alimentazione motore
Splicing connector with free-lever for the motor power source

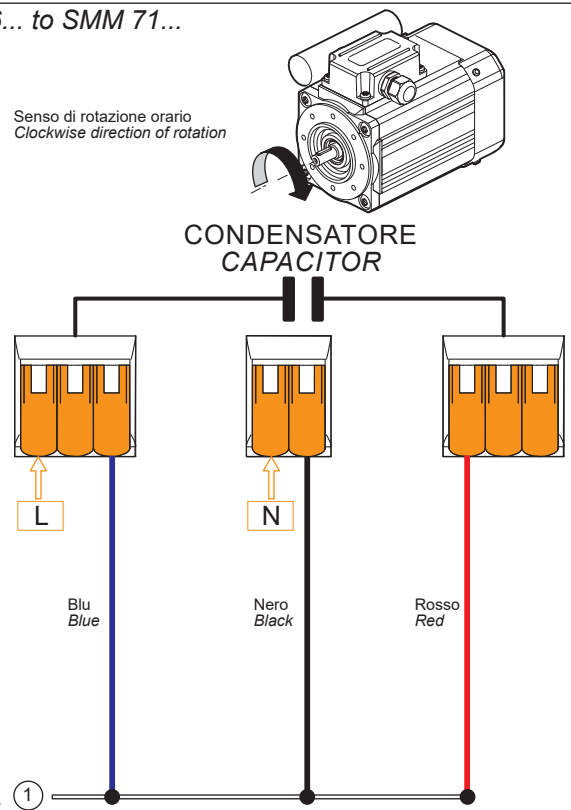

115 V - Monofase / single phase

Monofase da SMM 56... a SMM 71... / Single phase from SMM 56... to SMM 71...

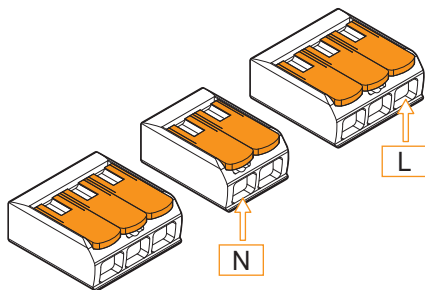

Morsetti a levetta liberi per alimentazione motore

Splicing connector with free-lever for the motor power source

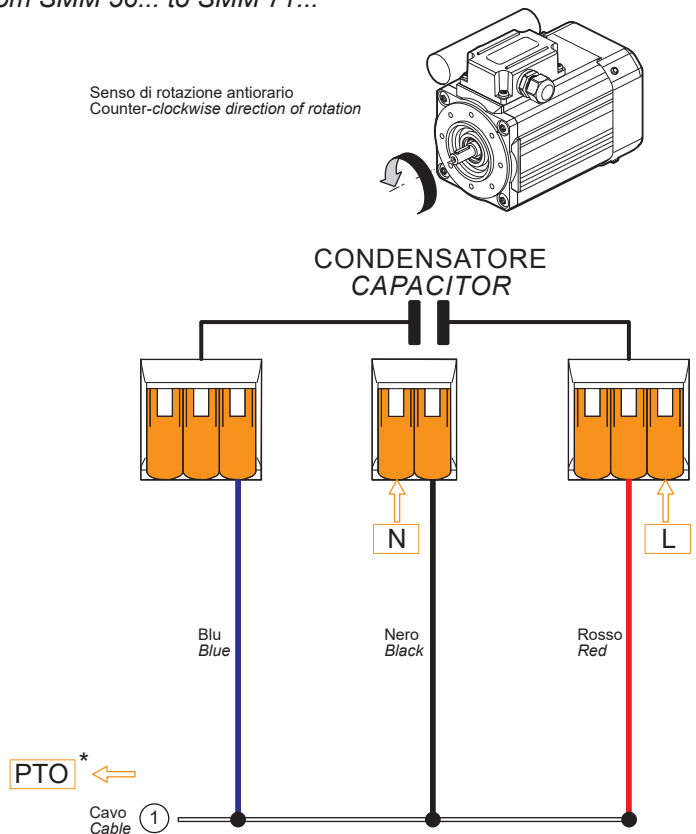

*: collegamento al circuito di comando del motore a cura del cliente. Per ragioni di sicurezza è sconsigliato il collegamento in serie. Se necessario contattare il Servizio Tecnico Transtecno.

*: motor supply connection by the customer. For safety reason Transtecno advises against PTO connected in series. If needed, contact Transtecno Technical Service.

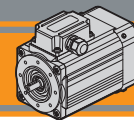
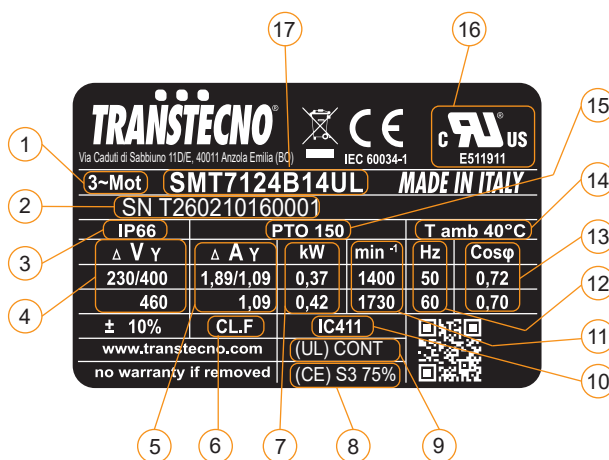
Targhetta
Nameplate

Pos.	Descrizione	Description
1	Tipo di alimentazione	Power supply
2	Numero di serie	Serial number
3	Grado di protezione IP motore	Motor IP protection rating
4	Tensione di alimentazione	Supply voltage
5	Corrente nominale	Rated current
6	Classe di isolamento	Insulation class
7	Potenza nominale	Rated power
8	Servizio per certificazione CE	CE compliance duty
9	Servizio per certificazione UL/CSA	UL/CSA compliance duty
10	Ventilazione	Fan cooling
11	Velocità nominale	Rated speed
12	Frequenza nominale	Rated frequency
13	Fattore di potenza	Power factor
14	Temperatura ambiente massima	Max allowed ambient temperature
15	Protezione termica PTO 150°C	PTO 150°C Thermal protection
16	Certificazione UL/CSA	UL/CSA compliance
17	Tipo di motore	Motor type

MINI **TECNO**
small but strong

CMG

AC

Motoriduttori CA ad ingranaggi cilindrici
AC Helical in-line gearmotors



MINI **TECNO** brand of
TRANSTECNO[®]



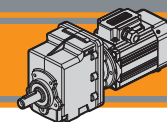

Indice	Index	Pag. Page
Caratteristiche tecniche	<i>Technical features</i>	AE2
Designazione	<i>Classification</i>	AE2
Sensi di rotazione	<i>Direction of rotation</i>	AE3
Lubrificazione	<i>Lubrication</i>	AE3
Simbologia	<i>Symbols</i>	AE3
Carichi radiali	<i>Radial loads</i>	AE3
Motori applicabili	<i>IEC Motor adapters</i>	AE4
Dati tecnici	<i>Technical data</i>	AE4
Dimensioni	<i>Dimensions</i>	AE6

Questa sezione annulla e sostituisce ogni precedente edizione o revisione. Qualora questa sezione non Vi sia giunta in distribuzione controllata, l'aggiornamento dei dati ivi contenuto non è assicurato. **In tal caso la versione più aggiornata è disponibile sul nostro sito internet www.transtecno.com**

This section replaces any previous edition and revision. If you obtained this catalogue other than through controlled distribution channels, the most up to date content is not guaranteed. In this case the latest version is available on our web site www.transtecno.com

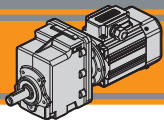

Caratteristiche tecniche

Technical features

Le caratteristiche principali dei motoriduttori CMG sono:

CMG gearmotor range has the following main features:

- Costruzione compatta
- Motorizzazioni in corrente alternata monofase e trifase
- Carcassa motore estrusa in alluminio anodizzato nero
- Carcasse dei riduttori in pressofusione di alluminio
- Motore elettrico AC con grado di protezione IP66
- Lubrificazione permanente con olio sintetico
- Ingranaggi cilindrici a denti elicoidali, induriti e rettificati
- Disponibili sia nella versione ventilata TEFC (servizio S1) che non ventilata TENV (servizio S3)
- Protezione termica PTO 150°C per le taglie motore 56, 63 e 71.
- SMT56, SMT63 e SMT71 adatti al funzionamento con alimentazione da inverter
- Disponibili nelle versioni autofrenante, servovenilata e con certificazione UL.
- Disponibili con giunto elastico in entrata

- Compact design
- AC single phase and three phase motors available
- Motor extruded aluminum housing black anodized
- Gearbox die-cast aluminum housing
- AC electric motor in IP66 protection Standard
- Permanent synthetic oil long-life lubrication
- Ground-hardened helical gears
- Fan cooled TEFC (duty S1) and not ventilated TENV (duty S3) versions available
- PTO 150°C thermal protection for motor sizes 56, 63 and 71.
- SMT56, SMT63 and SMT71 are suitable for inverter duty
- Brake motors, forced ventilation motors and UL compliance versions available.
- Available with input flexible couplin

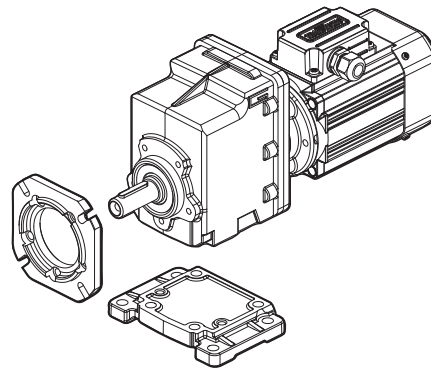

Designazione

Classification

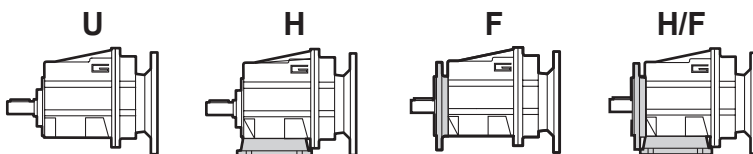

RIDUTTORE / GEARBOX

CMG	00	2	H60	10.16	D20	63	B14	FX
Tipo Type	Grandezza Size	Stadi Stages	Versione Version	Rapporto Ratio	Albero uscita Output shaft	IEC 	Forma costruttiva Version	Giunto elastico Flexible coupling
CMG	00	2 3	U... H... F... H.../F...	vedi tabelle see tables	vedi tabelle see tables	56.. 63.. 71..	B14	FX

MOTORE TRIFASE / THREE PHASE MOTOR

SMT	63	2	4	0.18 kW	B14	230-400 V	50 Hz	TEFC	BR	T1
Tipo Type	Grandezza Size	Indicativo potenza Power coefficient	Poli Poles	Potenza Power	Forma costruttiva Version	Tensione Voltage	Frequenza Frequency	Ventilazione Fan cooling	Opzioni Options	Pos. Morsetti Terminal box pos.
SMT 	Vedere tab. See tab.	1-2-3-4-5	4	0.04 kW ... 0.75 kW	B14	230-400 V 460V	50Hz 60Hz	TEFC TENV		T1 (Std)

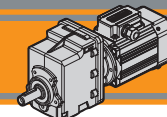

MOTORE MONOFASE / SINGLE PHASE MOTOR										
SMM	63	2	4	0.18 kW	B14	230 V	50 Hz	TEFC	UL-CSA	T1
Tipo Type	Grandezza Size	Indicativo potenza Power coefficient	Poli Poles	Potenza Power	Forma costruttiva Version	Tensione Voltage	Frequenza Frequency	Ventilazione Fan cooling	Opzioni Options	Pos. Morsetteria Terminal box pos.
SMM	Vedere tab. See tab.	1-2-3-4	4	0.04 kW ... 0.55 kW	B14	230V	50Hz	TEFC TENV	AD1	T1 (Std) T4 T2 T3

Sensi di rotazione

Direction of rotation

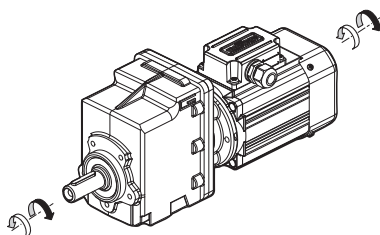

Lubrificazione

Lubrication

Tutti i riduttori sono forniti completi di lubrificante sintetico viscosità 320, pertanto possono essere installati in qualunque posizione di montaggio e non necessitano di manutenzione.

Permanent synthetic oil long-life lubrication (viscosity grade 320) makes it possible to use in all mounting positions; for this reason they can be installed in any assembly position and do not require maintenance.

Simbologia

Symbols

- n_1 [min⁻¹] Velocità in ingresso / Input speed
- n_2 [min⁻¹] Velocità in uscita / Output speed
- i Rapporto di riduzione / Ratio
- P_1 [kW] Potenza in entrata / Input power
- M_2 [Nm] Coppia nominale in uscita in funzione di P_1 / Output torque referred to P_1
- sf Fattore di servizio / Service factor
- R_2 [N] Carico radiale ammissibile in uscita / Permitted output radial load
- A_2 [N] Carico assiale ammissibile in uscita / Permitted output axial load

Carichi radiali

Radial loads

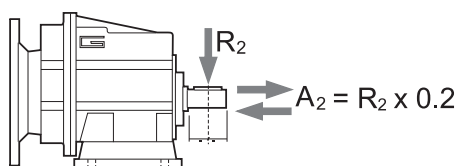

	CMG 002												
n_2 [min ⁻¹]	700	600	500	400	250	180	150	120	100	80	60	40	10
R_2 [N]	416	437	465	501	586	653	748	806	958	1032	1136	1300	1300

Quando il carico radiale risultante non è applicato sulla mezzeria dell'albero occorre calcolare quello effettivo con la seguente formula:

When the resulting radial load is not applied on the centre line of the shaft it is necessary to calculate the effective load with the following formula:

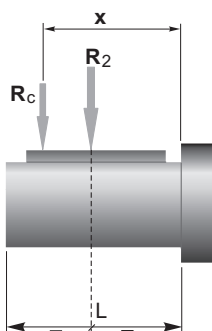

	CMG 002
a	73
b	53
R_{2MAX}	1300

$$R_c = \frac{R_2 \cdot a}{(b+x)} \leq R_{2MAX}$$

$a, b =$ valori riportati nella tabella
 $a, b =$ values given in the table

$$R \leq R_c$$

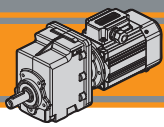

CMG

Motoriduttori CA ad ingranaggi cilindrici
AC Helical in-line gearmotors



Motori applicabili

IEC Motor adapters

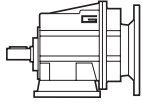
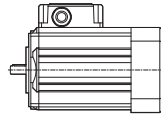





		SMT				SMM			
		5014 5024 5034 5044	5624 5634 5644 5654	6324 6334 6344	7124 7134 7144	5014 5024 5034	5624 5634 5644	6324 6334	7124 7134
CMG	002	5.03 - 55.10							

5.03 - 55.10 Rapporti di riduzione i / Ratio i

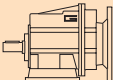
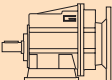
Dati tecnici

Technical data

P ₁ [kW]	n ₂ [min ⁻¹]	M ₂ [Nm]	sf	i		P ₁ [kW]	n ₂ [min ⁻¹]	M ₂ [Nm]	sf	i	
0.04						0.09					
SMT5014	279	1	30.4	5.03	CMG002	SMT5034	279	3	13.5	5.03	CMG002
SMM5014	230	2	25.0	6.10		SMM5034	230	4	11.1	6.10	
(1400 min ⁻¹)	187	2	20.4	7.49		SMT5624	187	4	9.1	7.49	
	156	2	21.2	8.99		SMM5624	156	5	9.4	8.99	
	138	3	18.8	10.16		(1400 min ⁻¹)	138	6	8.3	10.16	
	116	3	15.8	12.07			116	7	7.0	12.07	
	105	4	20.0	13.40			105	8	8.9	13.40	
	92	4	17.7	15.14			92	9	7.8	15.14	
	77	5	14.7	18.17			77	11	6.5	18.17	
	65	6	12.4	21.58			65	13	5.5	21.58	
	60	6	11.4	23.51			60	14	5.1	23.51	
	56	7	10.6	25.10			56	15	4.7	25.10	
	52	7	9.9	27.08			52	16	4.4	27.08	
	43	9	8.2	32.49			43	19	3.7	32.49	
	33	11	6.4	42.04		33	25	2.8	42.04		
	31	12	6.0	44.89		31	26	2.6	44.89		
	29	13	5.5	48.86		29	29	2.4	48.86		
	25	14	4.8	55.10		25	32	2.2	55.10		
0.06						0.12					
SMT5024	279	2	20.3	5.03	CMG002	SMT5044	279	4	10.1	5.03	CMG002
SMM5024	230	2	16.7	6.10		SMT5634	230	5	8.3	6.10	
(1400 min ⁻¹)	187	3	13.6	7.49		SMM5634	187	6	6.8	7.49	
	156	4	14.2	8.99		(1400 min ⁻¹)	156	7	7.1	8.99	
	138	4	12.5	10.16			138	8	6.3	10.16	
	116	5	10.5	12.07			116	9	5.3	12.07	
	105	5	13.3	13.40			105	11	6.7	13.40	
	92	6	11.8	15.14			92	12	5.9	15.14	
	77	7	9.8	18.17			77	14	4.9	18.17	
	65	8	8.3	21.58			65	17	4.1	21.58	
	60	9	7.6	23.51			60	18	3.8	23.51	
	56	10	7.1	25.10			56	20	3.5	25.10	
	52	11	6.6	27.08			52	21	3.3	27.08	
	43	13	5.5	32.49			43	26	2.7	32.49	
	33	17	4.2	42.04		33	33	2.1	42.04		
	31	18	4.0	44.89		31	35	2.0	44.89		
	29	19	3.6	48.86		29	38	1.8	48.86		
	25	22	3.2	55.10		25	43	1.6	55.10		



Motori Motors	SMT		SMM	
		5014 5024 5034 5044	5624 5634	5014 5024 5034
IEC	56 B14		56 B14	

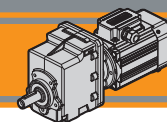

Dati tecnici

Technical data

P ₁ [kW]	n ₂ [min ⁻¹]	M ₂ [Nm]	sf	i	
------------------------	--	------------------------	----	---	--

P ₁ [kW]	n ₂ [min ⁻¹]	M ₂ [Nm]	sf	i	
------------------------	--	------------------------	----	---	--

0.18

SMT5644	279	6	6.8	5.03	CMG002
SMM5644	230	7	5.6	6.10	
SMT6324	187	9	4.5	7.49	
SMM6324	156	11	4.7	8.99	
(1400 min ⁻¹)	138	12	4.2	10.16	
	116	14	3.5	12.07	
	105	16	4.4	13.40	
	92	18	3.9	15.14	
	77	21	3.3	18.17	
	65	25	2.8	21.58	
	60	28	2.5	23.51	
	56	30	2.4	25.10	
	52	32	2.2	27.08	
	43	38	1.8	32.49	
	33	50	1.4	42.04	
	31	53	1.3	44.89	
	29	58	1.2	48.86	
	25	65	1.1	55.10	

0.37

SMT6344	279	12	3.3	5.03	CMG002
SMT7124	230	15	2.7	6.10	
SMM7124	187	18	2.2	7.49	
(1400 min ⁻¹)	156	22	2.3	8.99	
	138	25	2.0	10.16	
	116	29	1.7	12.07	
	105	32	2.2	13.40	
	92	37	1.9	15.14	
	77	44	1.6	18.17	
	65	52	1.3	21.58	
	60	57	1.2	23.51	
	56	61	1.2	25.10	
	52	66	1.1	27.08	
	43	79	0.9	32.49	

0.25

SMT5654	279	8	4.9	5.03	CMG002
SMT6334	230	10	4.0	6.10	
SMM6334	187	12	3.3	7.49	
(1400 min ⁻¹)	156	15	3.4	8.99	
	138	17	3.0	10.16	
	116	20	2.5	12.07	
	105	22	3.2	13.40	
	92	25	2.8	15.14	
	77	30	2.4	18.17	
	65	35	2.0	21.58	
	60	38	1.8	23.51	
	56	41	1.7	25.10	
	52	44	1.6	27.08	
	43	53	1.3	32.49	
	33	69	1.0	42.04	
	31	73	1.0	44.89	
	29	80	0.9	48.86	
	25	90	0.8	55.10	

0.55

SMT7134	279	18	2.2	5.03	CMG002
SMM7134	230	22	1.8	6.10	
(1400 min ⁻¹)	187	27	1.5	7.49	
	156	32	1.5	8.99	
	138	37	1.4	10.16	
	116	43	1.2	12.07	
	105	48	1.5	13.40	
	92	55	1.3	15.14	
	77	65	1.1	18.17	
	65	78	0.9	21.58	

0.75

SMT7144	279	25	1.6	5.03	CMG002
(1400 min ⁻¹)	230	30	1.3	6.10	
	187	37	1.1	7.49	
	156	44	1.1	8.99	
	138	50	1.0	10.16	
	116	59	0.8	12.07	
	105	66	1.1	13.40	
	92	74	0.9	15.14	



Motori Motors	SMT			SMM		
		5644 5654	6324 6334 6344	7124 7134 7144	5644	6324 6334
IEC	56 B14	63 B14	71 B14	56 B14	63 B14	71 B14

Dati tecnici elettrici

Electrical technical data



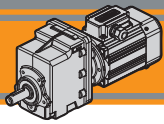

CMG

Motoriduttori CA ad ingranaggi cilindrici
AC Helical in-line gearmotors

MINI
TECNO

Dimensioni

Dimensions

CMG 002 U

CMG 002 U

SMT50...TEFC
SMM50... TEFC

SMT50...TENV
SMM50... TENV

S3 servizio 30%
duty

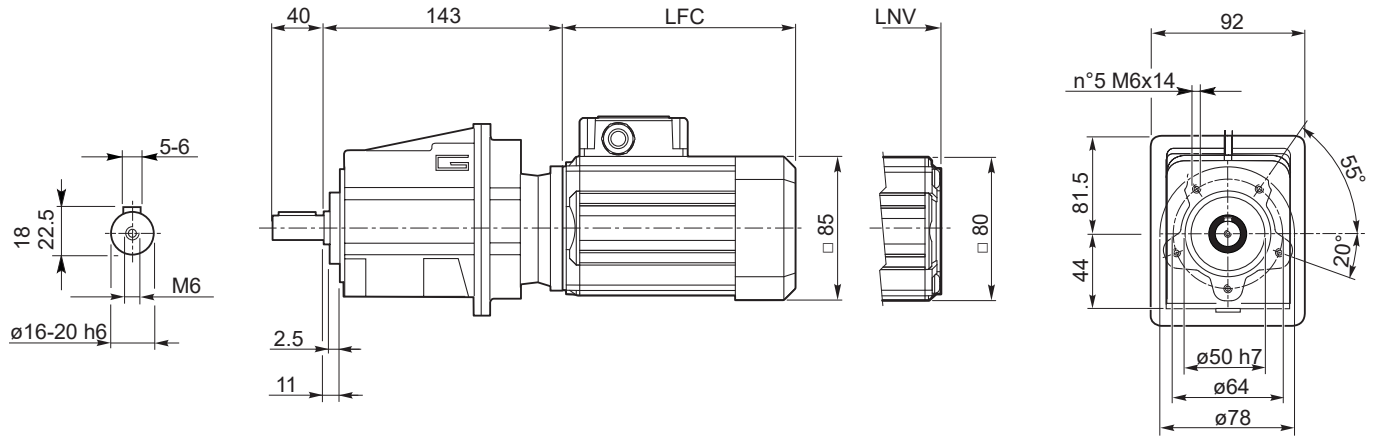

SMT	LFC	LNV	Kg	
5014	135.5	108.5	5.2	
5024	150.5	123.5	5.6	
5034	175.5	148.5	6.4	
5044	200.5	173.5	7.1	

SMM	LFC	LNV	Kg	
5014	150.5	123.5	5.6	
5024	175.5	148.5	6.4	
5034	200.5	173.5	7.1	

Nota: il condensatore sarà fornito a corredo
Note: the capacitor will be supplied separately

- CMG...H → AE8
- CMG...F → AE8
- CMG...H/F → AE9

CMG 002 U

SMT56...TEFC
SMM56... TEFC

SMT56...TENV
SMM56... TENV

S3 servizio 30%
duty

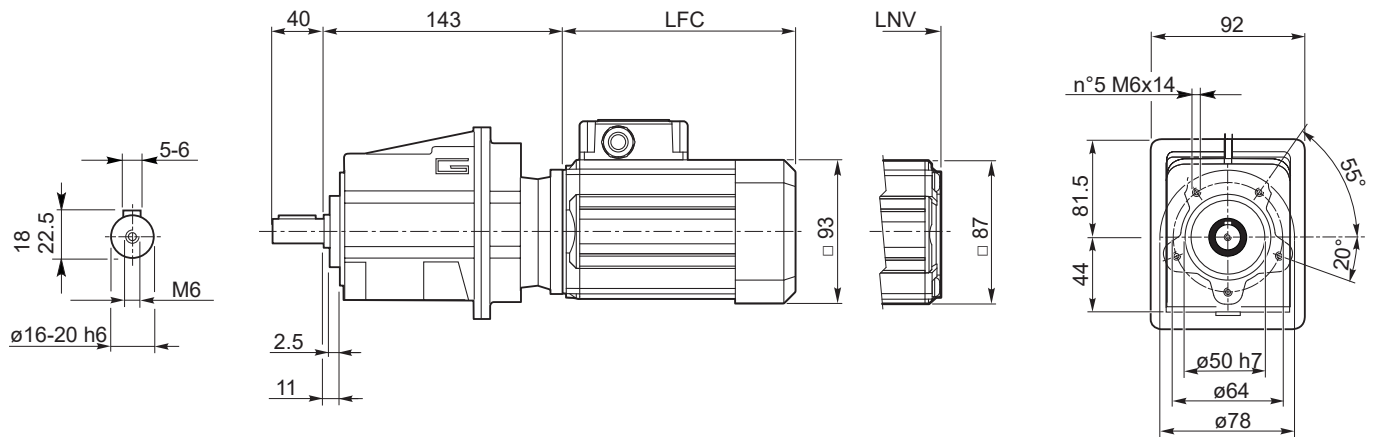

SMT	LFC	LNV	Kg	
5624	141	117	5.7	
5634	151	127	6.1	
5644	186	162	7.3	
5654	206	182	8	

SMM	LFC	LNV	Kg	
5624	151	127	6	
5634	171	147	6.6	
5644	206	182	7.9	

Nota: il condensatore sarà fornito a corredo
Note: the capacitor will be supplied separately

- CMG...H → AE8
- CMG...F → AE8
- CMG...H/F → AE9

SMT SMM
OPTIONS → AB1 AC1 AD1

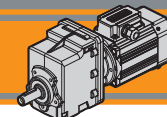

Dimensioni

Dimensions

CMG 002 U

CMG 002 U

SMT63...TEFC
SMM63... TEFC

SMT63...TENV
SMM63... TENV

S3 servizio duty 30%

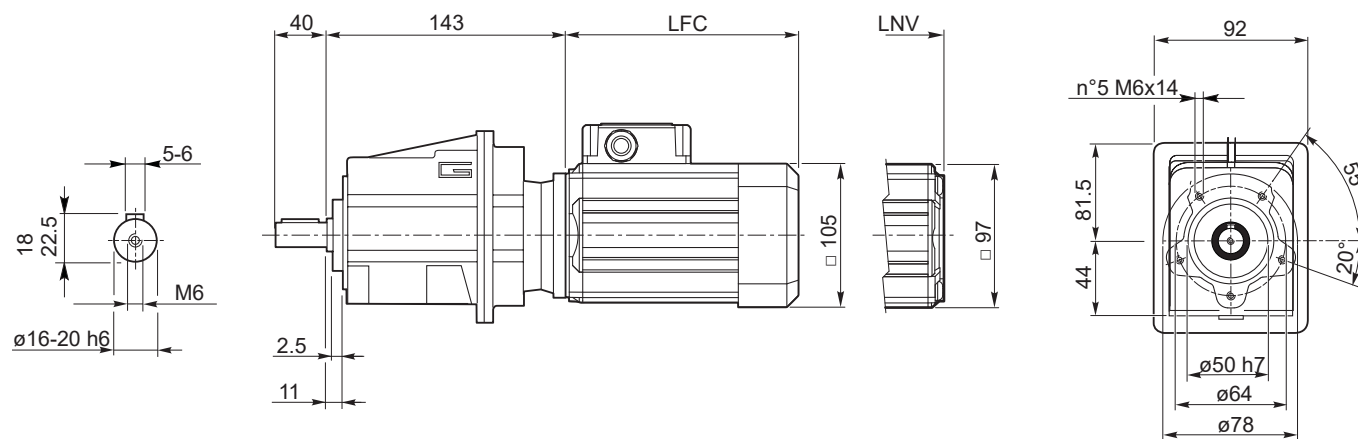

SMT	LFC	LNV	Kg	
6324	165.5	138.5	7.2	
6334	180.5	153.5	7.9	
6344	205.5	178.5	9.1	

SMM	LFC	LNV	Kg	
6324	180.5	153.5	8	
6334	205.5	178.5	9.2	

Nota: il condensatore sarà fornito a corredo
Note: the capacitor will be supplied separately

CMG...H → AE8

CMG...F → AE8

CMG...H/F → AE9

→ AB1 AC1 AD1

CMG 002 U

SMT71...TEFC
SMM71... TEFC

SMT71...TENV
SMM71... TENV

S3 servizio duty 30%

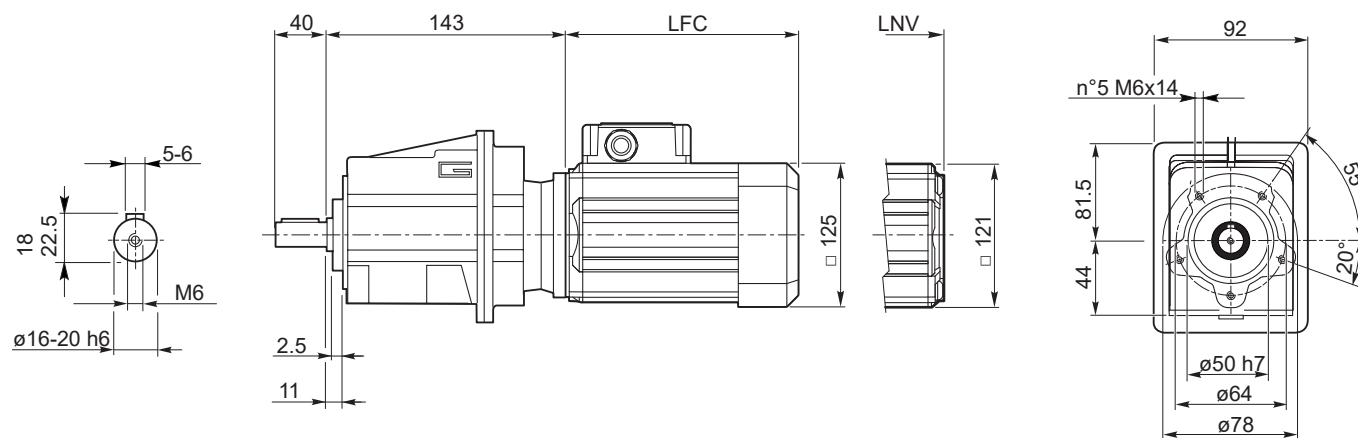

SMT	LFC	LNV	Kg	
7124	174	174	9.4	
7134	189	189	10.5	
7144	214	214	12.2	

SMM	LFC	LNV	Kg	
7124	189	160.5	10.1	
7134	214	185.5	12.1	

Nota: il condensatore sarà fornito a corredo
Note: the capacitor will be supplied separately

CMG...H → AE8

CMG...F → AE8

CMG...H/F → AE9

→ AB1 AC1 AD1

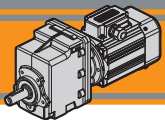

CMG

Motoriduttori CA ad ingranaggi cilindrici
AC Helical in-line gearmotors

MINI
TECNO

Dimensioni

Dimensions

CMG..H

CMG002 H..

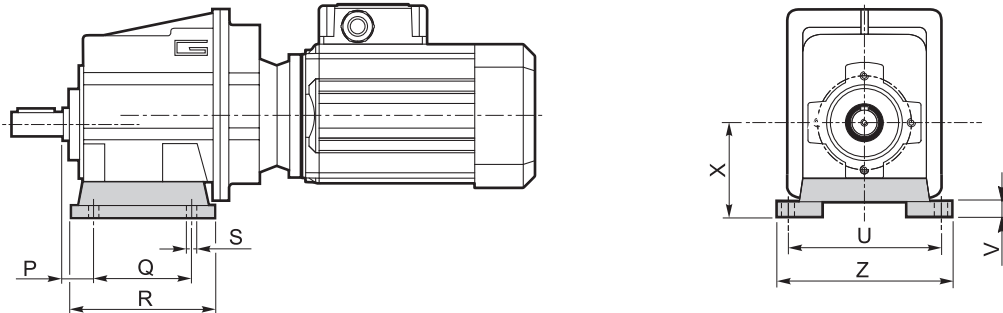

Versione H / H Version										
CMG	P	Q	R	S	U	V	X	Z	Piede / Foot	
									Tipo / Type	Peso / Weight [kg]
002	18	60	80	9	100	10	60	120	H60	0.2
	18	80	104	9	110 - 120	10	75	145	H75	0.3
	18	50 - 87	110	9	110	10	85	135	H85	0.4

■ Preferenziale / Preferred

CMG..F

CMG002 F..

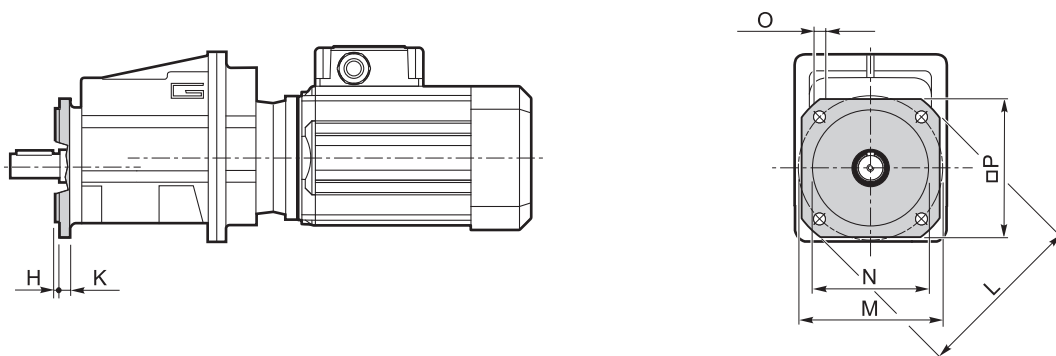

Versione F / F Version										
CMG	H	K	L	M	N f7	O	P	Flangia / Flange		
								Tipo / Type	Peso / Weight [kg]	
002	3.5	7	105	85	70	6.5	90	F105	0.1	
	3.5	8	120	100	80	9	100	F120	0.2	
	3.5	8	140	115	95	9	115	F140	0.2	

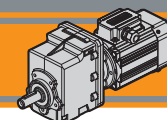

Dimensioni

Dimensions

CMG..H../F..

CMG002 H../F..

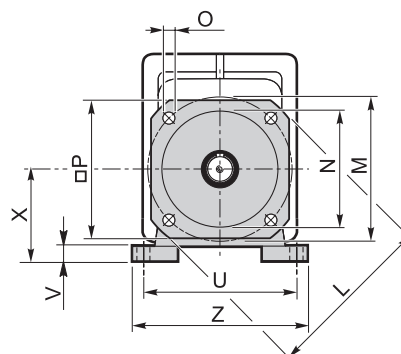
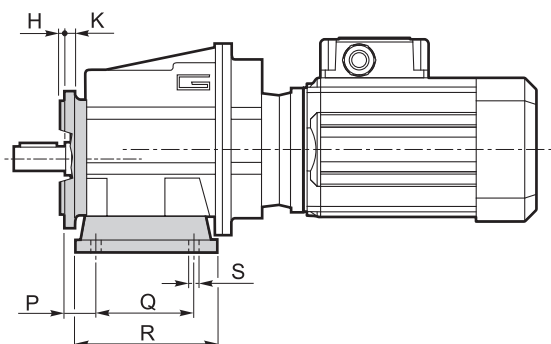

Versione H / H Version										Combinazioni possibili H/F Possible combinations H/F							
CMG	P	Q	R	S	U	V	X	Z	Piede / Foot		F105	F120	F140	F160	F200	F250	F300
									Tipo / Type	Peso / Weight [kg]							
002	18	60	80	9	100	10	60	120	H60	0.2	•	•	•				
	18	80	104	9	110 - 120	10	75	145	H75	0.3	•	•	•				
	18	50 - 87	110	9	110	10	85	135	H85	0.4	•	•	•				

Preferenziale / Preferred

• Combinazioni possibili H/F / Possible combinations H/F

Versione F / F Version									
CMG	H	K	L	M	N f7	O	P	Flangia / Flange	
								Tipo / Type	Peso / Weight [kg]
002	3.5	7	105	85	70	6.5	90	F105	0.1
	3.5	8	120	100	80	7	100	F120	0.2
	3.5	8	140	115	95	9	115	F140	0.2

MINI  **TECNO**™
small but strong

CMB

AC

Motoriduttori CA ad assi ortogonali
AC Helical bevel gearmotors

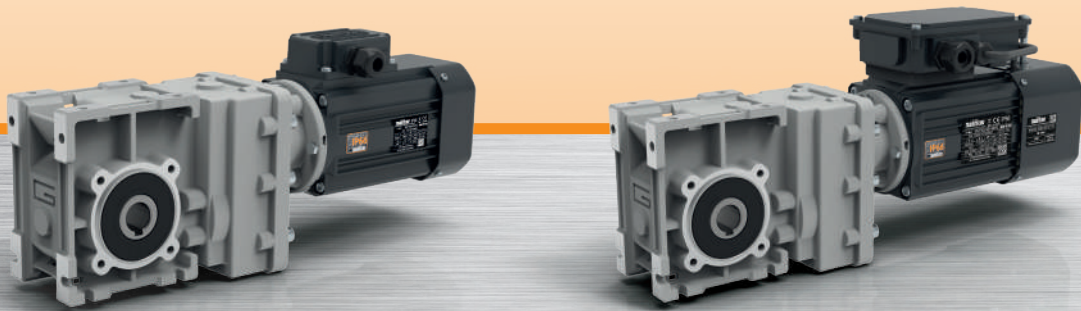

MINI  **TECNO**™ brand of
TRANSTECNO®



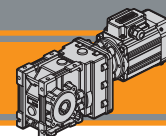

Indice	Index	Pag. Page
Caratteristiche tecniche	<i>Technical features</i>	AC2
Designazione	<i>Classification</i>	AC2
Sensi di rotazione	<i>Direction of rotation</i>	AC3
Simbologia	<i>Symbols</i>	AC3
Lubrificazione	<i>Lubrication</i>	AC3
Carichi radiali	<i>Radial loads</i>	AC3
Motori applicabili	<i>Motor adapters</i>	AC4
Dati tecnici	<i>Technical data</i>	AC4
Dimensioni	<i>Dimensions</i>	AC7
Accessori	<i>Accessories</i>	AC8

Questa sezione annulla e sostituisce ogni precedente edizione o revisione. Qualora questa sezione non Vi sia giunta in distribuzione controllata, l'aggiornamento dei dati ivi contenuto non è assicurato. **In tal caso la versione più aggiornata è disponibile sul nostro sito internet www.transtecno.com**

This section replaces any previous edition and revision. If you obtained this catalogue other than through controlled distribution channels, the most up to date content is not guaranteed. In this case the latest version is available on our web site www.transtecno.com

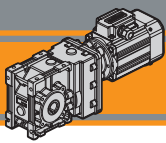

CMB

Motoriduttori CA ad assi ortogonali
AC Helical bevel gearmotors



Caratteristiche tecniche

Technical features

Le caratteristiche principali dei motoriduttori CMB sono:

CMB gearmotor range has the following main features:

- Costruzione compatta
- Motorizzazioni in corrente alternata monofase e trifase
- Carcassa motore estrusa in alluminio anodizzato nero
- Carcasse dei riduttori in pressofusione di alluminio
- Motore elettrico AC con grado di protezione IP66
- Lubrificazione permanente con olio sintetico
- Ingranaggi cilindrici a denti elicoidali, induriti e rettificati
- Disponibili sia nella versione ventilata TEFC (servizio S1) che non ventilata TENV (servizio S3)
- Protezione termica PTO 150°C per le taglie motore 56, 63 e 71.
- SMT56, SMT63 e SMT71 adatti al funzionamento con alimentazione da inverter
- Disponibili nelle versioni autofrenante, servoventilata e con certificazione UL.
- Disponibili con giunto elastico in entrata

- Compact design
- AC single phase and three phase motors available
- Motor extruded aluminum housing black anodized
- Gearbox die-cast aluminum housing
- AC electric motor in IP66 protection Standard
- Permanent synthetic oil long-life lubrication
- Ground-hardened helical gears
- Fan cooled TEFC (duty S1) and not ventilated TENV (duty S3) versions available
- PTO 150°C thermal protection for motor sizes 56, 63 and 71.
- SMT56, SMT63 and SMT71 are suitable for inverter duty
- Brake motors, forced ventilation motors and UL compliance versions available.
- Available with input flexible couplin

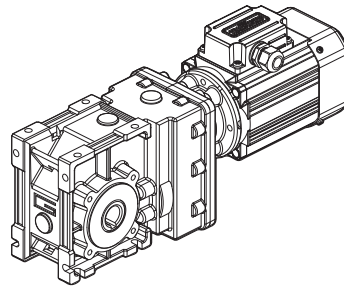

Designazione

Classification

RIDUTTORE / GEARBOX											
CMB	40	2	U	9.81	D20	63	B14	SZDX	BRSX	90	FX
Tipo Type	Grandezza Size	Stadi Stages	Versione Version	Rapporto Ratio	Albero cavo uscita Hollow output shaft	IEC	Forma costruttiva Version	Albero di uscita Output shaft	Braccio di reazione Torque arm	Angolo Angle	Giunto elastico Flexible coupling
	40	2	U FD FS FBD FBS FLD FLS	vedi tabelle see tables	vedi tabelle see tables	 56.. 63.. 71..	B14	SZDX SZSX DZ	BRDX BRSX *	0° 90° 180° 270°	FX 17
Versione Riduttore Gearbox Version			Albero di uscita Output shaft			Braccio di reazione Torque arm *		Angolo Angle			
 U FD FS FLD FBD FBS			 SZDX SZSX DZ			 BRDX BRSX		 90° 90° 180° 270°			

* NOTA: il braccio di reazione viene fornito smontato.
NOTE: the torque arm will be supplied not assembled.

MOTORE TRIFASE / THREE PHASE MOTOR										
SMT	63	2	4	0.18 kW	B14	230-400 V	50 Hz	TEFC	BR	T1
Tipo Type	Grandezza Size	Indicativo potenza Power coefficient	Poli Poles	Potenza Power	Forma costruttiva Version	Tensione Voltage	Frequenza Frequency	Ventilazione Fan cooling	Opzioni Options	Pos. Morsettiera Terminal box pos.
SMT 	Vedere tab. See tab.	1-2-3-4-5	4	0.04 kW ... 0.75 kW	B14	230-400 V 460V	50Hz 60Hz	TEFC TENV	 AB1 AC1 AD1	T1 (Std) T4 T2 T3

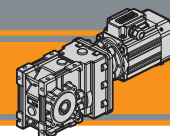

MOTORE MONOFASE / SINGLE PHASE MOTOR										
SMM	63	2	4	0.18 kW	B14	230 V	50 Hz	TEFC	UL-CSA	T1
Tipo Type	Grandezza Size	Indicativo potenza Power coefficient	Poli Poles	Potenza Power	Forma costruttiva Version	Tensione Voltage	Frequenza Frequency	Ventilazione Fan cooling	Opzioni Options	Pos. Morsetteria Terminal box pos.
SMM	Vedere tab. See tab.	1-2-3-4	4	0.04 kW ... 0.55 kW	B14	230V	50Hz	TEFC TENV	AD1	T1 (Std) T4 T3

Sensi di rotazione

Direction of rotation

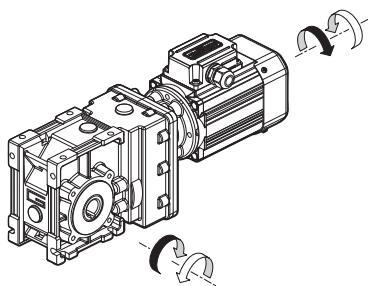

Simbologia

Symbols

n_1 [min ⁻¹]	Velocità in ingresso / <i>Input speed</i>	M_2 [Nm]	Coppia in uscita in funzione di P_1 / <i>Output torque referred to P_1</i>
n_2 [min ⁻¹]	Velocità in uscita / <i>Output speed</i>	sf	Fattore di servizio / <i>Service factor</i>
i	Rapporto di riduzione / <i>Ratio</i>	A_2 [N]	Carico assiale ammissibile in uscita / <i>Permitted output axial load</i>
P_1 [kW]	Potenza in entrata / <i>Input power</i>	R_2 [N]	Carico radiale ammissibile in uscita / <i>Permitted output radial load</i>

Lubrificazione

Lubrication

Tutti i riduttori nelle taglie 402 sono forniti completi di lubrificante sintetico viscosità 320, pertanto possono essere installati in qualunque posizione di montaggio e non necessitano di manutenzione.

Permanent synthetic oil long-life lubrication (viscosity grade 320) makes it possible to use sizes 402 in all mounting positions; for this reason they can be installed in any assembly position and do not require maintenance.

Carichi radiali

Radial loads

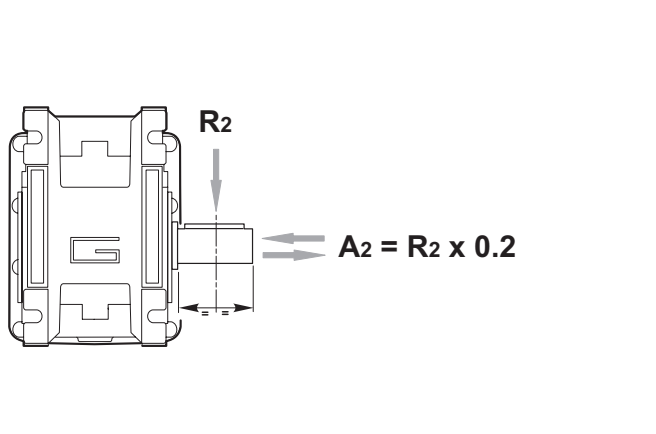

n_2 [min ⁻¹]	R_2 [N]
	CMB 402
400	905
300	996
200	1141
170	1204
140	1414
100	1582
90	1638
60	2047
40	2524
30	2778
20	3180
15	3500
10	3500

Quando il carico radiale risultante non è applicato sulla mezza-ria dell'albero occorre calcolare quello effettivo con la seguente formula:

When the resulting radial load is not applied on the centre line of the shaft it is necessary to calculate the effective load with the following formula:

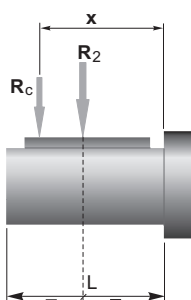

	CMB 402
a	86
b	66
R_{2MAX}	3500

$$R_c = \frac{R_2 \cdot a}{(b + x)} \leq R_{2MAX}$$

$$R \leq R_c$$

*a, b = valori riportati nella tabella
a, b = values given in the table*

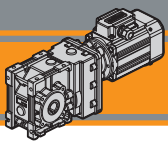

CMB

Motoriduttori CA ad assi ortogonali
AC Helical bevel gearmotors



Motori applicabili

Motor adapters

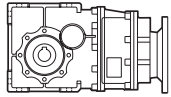
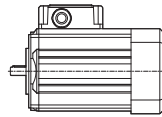





		SMT				SMM			
		5014 5024 5034 5044	5624 5634 5644 5654	6324 6334 6344	7124 7134 7144	5014 5024 5034	5624 5634 5644	6324 6334	7124 7134
CMB	402	6.18 - 72.50							

6.18 - 72.50

Rapporti di riduzione i
Ratio i

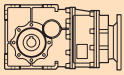
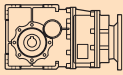
Dati tecnici

Technical data

P ₁ [kW]	n ₂ [min ⁻¹]	M ₂ [Nm]	sf	i		P ₁ [kW]	n ₂ [min ⁻¹]	M ₂ [Nm]	sf	i	
0.04						0.06					
SMT5014	227	2	25.3	6.18	CMB402	SMT5024	42	13	5.0	33.57	CMB402
SMM5014	187	2	20.8	7.49		SMM5024	39	14	4.7	35.63	
(1400 min ⁻¹)	152	2	16.9	9.20		(1400 min ⁻¹)	33	16	4.0	42.75	
	118	3	14.8	11.83			25	21	3.1	55.31	
	112	3	14.1	12.48			24	23	2.9	59.06	
	94	4	11.8	14.83			22	25	2.6	64.29	
	79	5	10.0	17.63			19	28	2.3	72.50	
	75	5	11.5	18.60							
	63	6	9.6	22.33							
	59	6	9.0	23.91							
	48	7	8.8	28.89							
	45	8	8.2	30.84							
	42	9	7.5	33.57							
	39	9	7.1	35.63							
	33	11	5.9	42.75							
	25	14	4.6	55.31							
	24	15	4.3	59.06							
	22	16	3.9	64.29							
	19	19	3.5	72.50							
0.06						0.09					
SMT5024	227	2	16.8	6.18	CMB402	SMT5034	227	4	11.2	6.18	CMB402
SMM5024	187	3	13.9	7.49		SMM5034	187	4	9.3	7.49	
(1400 min ⁻¹)	152	4	11.3	9.20		(1400 min ⁻¹)	152	5	7.5	9.20	
	118	5	9.9	11.83			118	7	6.6	11.83	
	112	5	9.4	12.48			112	7	6.2	12.48	
	94	6	7.9	14.83			94	9	5.3	14.83	
	79	7	6.6	17.63			79	10	4.4	17.63	
	75	7	7.7	18.60			75	11	5.1	18.60	
	63	9	6.4	22.33			63	13	4.3	22.33	
	59	9	6.0	23.91			59	14	4.0	23.91	
	48	11	5.8	28.89			48	17	3.9	28.89	
	45	12	5.5	30.84			45	18	3.7	30.84	
							42	19	3.4	33.57	
							39	21	3.2	35.63	
							33	25	2.6	42.75	
							25	32	2.0	55.31	
						24	34	1.9	59.06		
						22	37	1.8	64.29		
						19	42	1.6	72.50		



Motori Motors	SMT		SMM	
		5014 5024 5034	5624	5014 5024 5034
IEC	56 B14		56 B14	

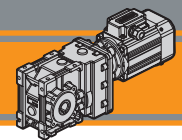

Dati tecnici

Technical data

P ₁ [kW]	n ₂ [min ⁻¹]	M ₂ [Nm]	sf	i	
0.12					
SMT5044	227	5	8.4	6.18	CMB402
SMT5634	187	6	6.9	7.49	
SMM5634	152	7	5.6	9.20	
(1400 min ⁻¹)	118	9	4.9	11.83	
	112	10	4.7	12.48	
	94	11	3.9	14.83	
	79	14	3.3	17.63	
	75	14	3.8	18.60	
	63	17	3.2	22.33	
	59	18	3.0	23.91	
	48	22	2.9	28.89	
	45	24	2.7	30.84	
	42	26	2.5	33.57	
	39	27	2.4	35.63	
	33	33	2.0	42.75	
	25	43	1.5	55.31	
	24	45	1.4	59.06	
	22	49	1.3	64.29	
	19	56	1.2	72.50	

P ₁ [kW]	n ₂ [min ⁻¹]	M ₂ [Nm]	sf	i	
0.18					
SMT5644	227	7	5.6	6.18	CMB402
SMM5644	187	9	4.6	7.49	
SMT6324	152	11	3.8	9.20	
SMM6324	118	14	3.3	11.83	
(1400 min ⁻¹)	112	14	3.1	12.48	
	94	17	2.6	14.83	
	79	20	2.2	17.63	
	75	21	2.6	18.60	
	63	26	2.1	22.33	
	59	28	2.0	23.91	
	48	33	1.9	28.89	
	45	36	1.8	30.84	
	42	39	1.7	33.57	
	39	41	1.6	35.63	
	33	49	1.3	42.75	
	25	64	1.0	55.31	
	24	68	0.95	59.06	
	22	74	0.88	64.29	
	19	84	0.8	72.50	

P ₁ [kW]	n ₂ [min ⁻¹]	M ₂ [Nm]	sf	i	
0.25					
SMT5654	227	10	4.0	6.18	CMB402
SMT6334	187	12	3.3	7.49	
SMM6334	152	15	2.7	9.20	
(1400 min ⁻¹)	118	19	2.4	11.83	
	112	20	2.2	12.48	
	94	24	1.9	14.83	
	79	28	1.6	17.63	
	75	30	1.8	18.60	
	63	36	1.5	22.33	
	59	38	1.4	23.91	
	48	46	1.4	28.89	
	45	49	1.3	30.84	
	42	54	1.2	33.57	
	39	57	1.1	35.63	
	33	69	0.9	42.75	

P ₁ [kW]	n ₂ [min ⁻¹]	M ₂ [Nm]	sf	i	
0.37					
SMT6344	227	15	2.7	6.18	CMB402
SMT7124	187	18	2.3	7.49	
SMM7124	152	22	1.8	9.20	
(1400 min ⁻¹)	118	28	1.6	11.83	
	112	30	1.5	12.48	
	94	35	1.3	14.83	
	79	42	1.1	17.63	
	75	44	1.2	18.60	
	63	53	1.0	22.33	
	59	57	1.0	23.91	
	48	69	0.9	28.89	
	45	73	0.9	30.84	
	42	80	0.8	33.57	

P ₁ [kW]	n ₂ [min ⁻¹]	M ₂ [Nm]	sf	i	
0.55					
SMT7134	227	22	1.8	6.18	CMB402
SMM7134	187	26	1.5	7.49	
(1400 min ⁻¹)	152	32	1.2	9.20	
	118	42	1.1	11.83	
	112	44	1.0	12.48	
	94	52	0.9	14.83	

P ₁ [kW]	n ₂ [min ⁻¹]	M ₂ [Nm]	sf	i	
0.75					
SMT7144	227	30	1.3	6.18	CMB402
(1400 min ⁻¹)	187	36	1.1	7.49	
	152	44	0.9	9.20	



Motori Motors	SMT				SMM		
	5044	5634 5644 5654	6324 6334 6344	7124 7134 7144	5644	6324 6334	7124 7134
IEC	56 B14		63 B14	71 B14	56 B14	63 B14	71 B14

Dati tecnici elettrici

Electrical technical data



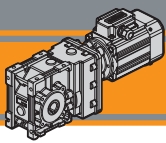

CMB

Motoriduttori CA ad assi ortogonali
AC Helical bevel gearmotors

MINI
TECNO

Dimensioni

Dimensions

CMB 402 U

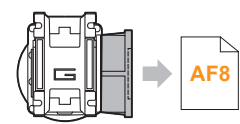
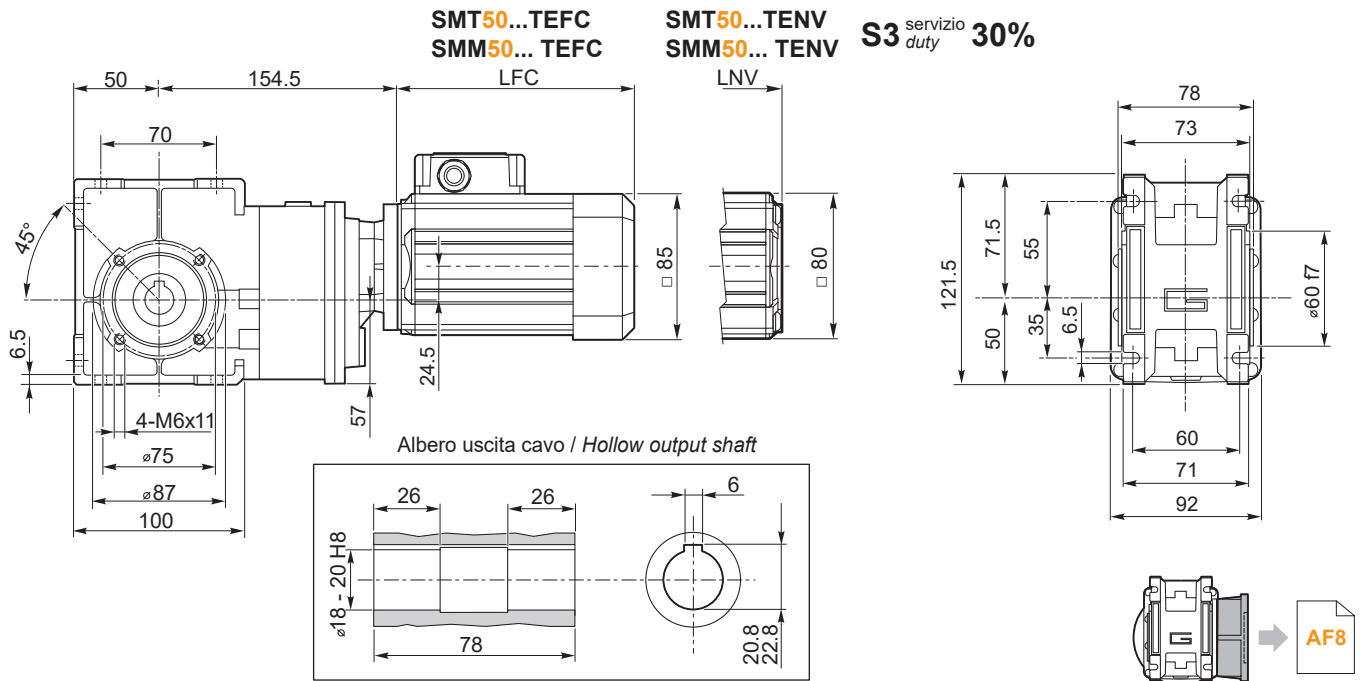

SMT	LFC	LNV	Kg	
5014	135.5	108.5	5.7	
5024	150.5	123.5	6.1	
5034	175.5	148.5	6.9	
5044	200.5	173.5	7.6	

SMM	LFC	LNV	Kg	
5014	150.5	123.5	6.1	
5024	175.5	148.5	6.9	
5034	200.5	173.5	7.6	

Nota:
il condensatore sarà fornito a corredo

Note:
the capacitor will be supplied separately

CMB 402 U

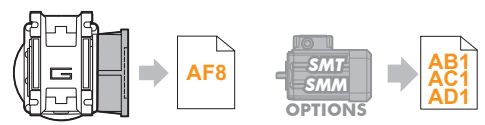
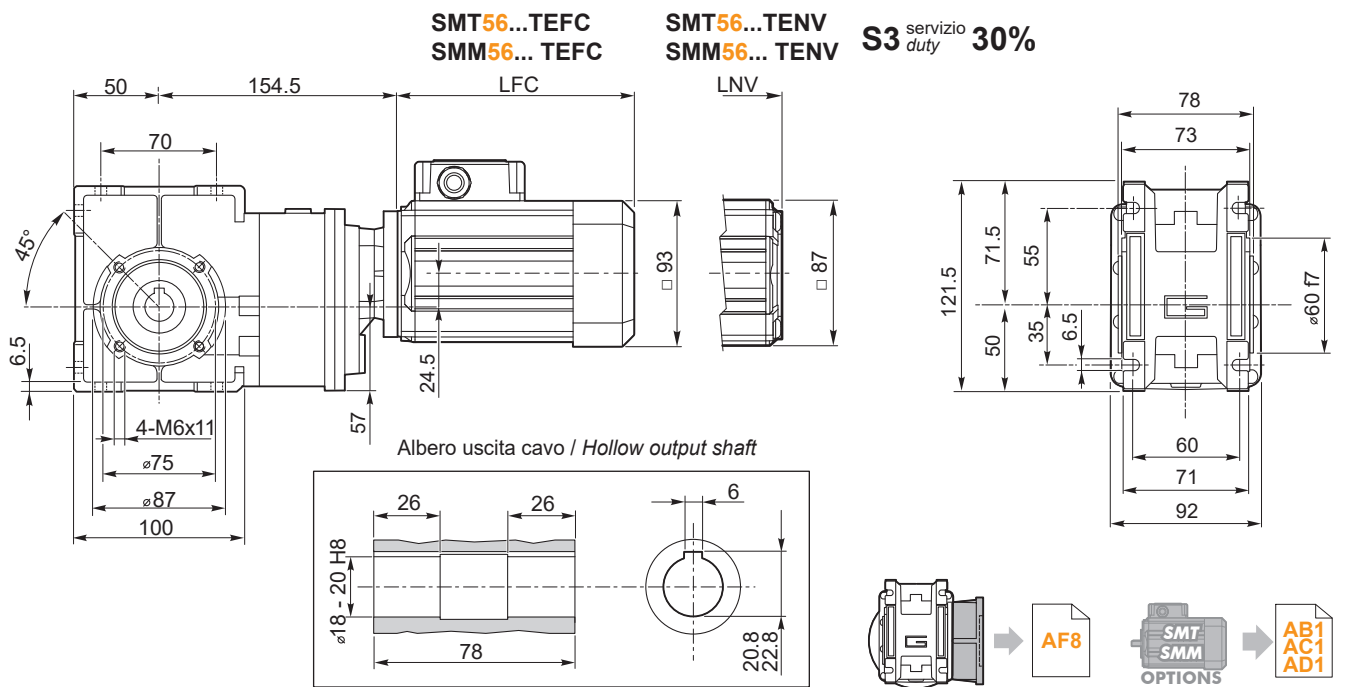

SMT	LFC	LNV	Kg	
5624	141	117	6.2	
5634	151	127	6.6	
5644	186	162	7.8	
5654	206	182	8.5	

SMM	LFC	LNV	Kg	
5624	151	127	6.5	
5634	171	147	7.1	
5644	206	182	8.4	

Nota:
il condensatore sarà fornito a corredo

Note:
the capacitor will be supplied separately

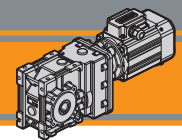

Dimensioni

Dimensions

CMB 402 U

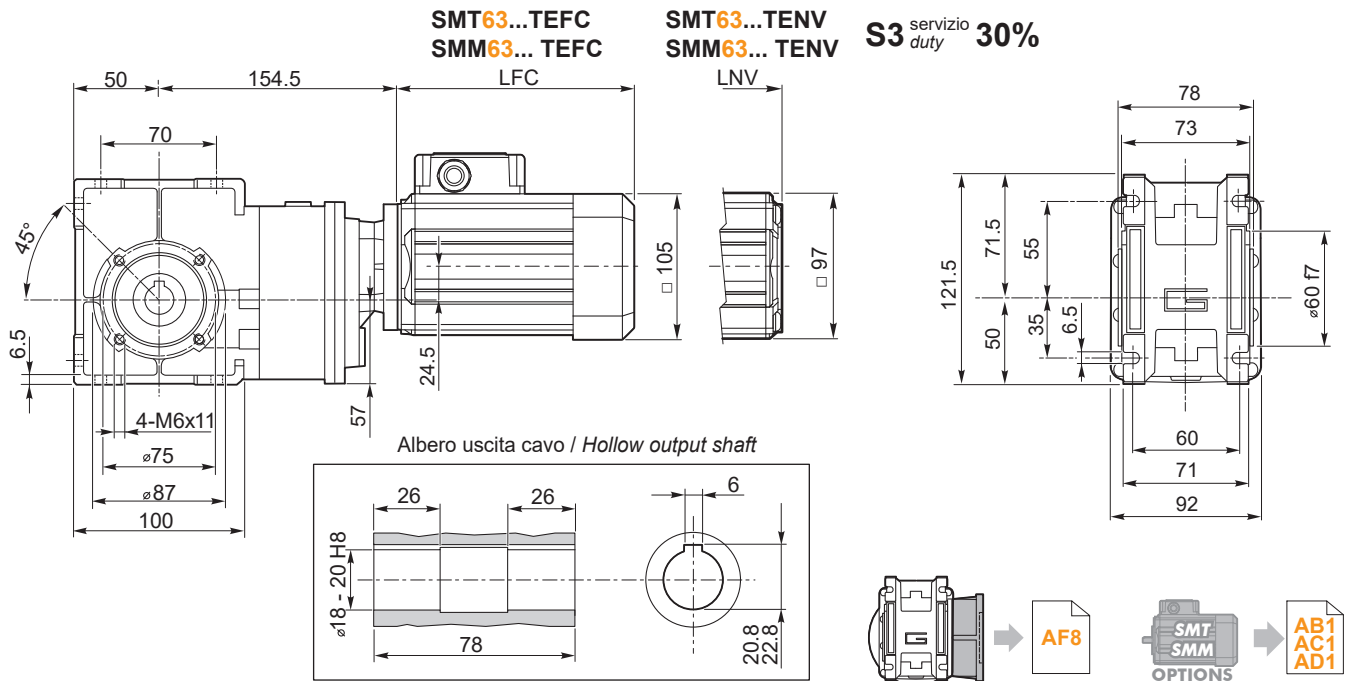

SMT	LFC	LNV	Kg	
6324	165.5	138.5	7.7	
6334	180.5	153.5	8.4	
6344	205.5	178.5	9.6	

SMM	LFC	LNV	Kg	
6324	180.5	153.5	8.5	
6334	205.5	178.5	9.7	

Nota:
il condensatore sarà fornito a corredo

Note:
the capacitor will be supplied separately

CMB 402 U

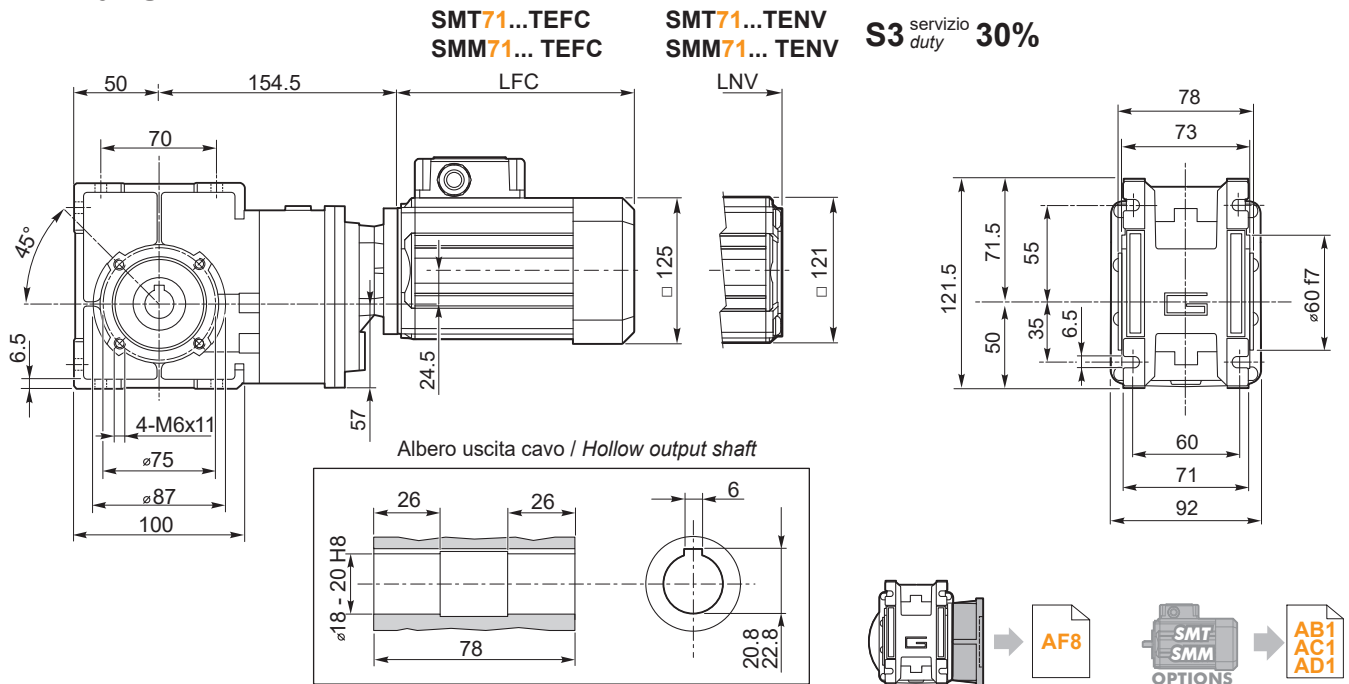

SMT	LFC	LNV	Kg	
7124	174	145.5	9.9	
7134	189	160.5	11	
7144	214	185.5	12.7	

SMM	LFC	LNV	Kg	
7124	189	160.5	10.6	
7134	214	185.5	12.6	

Nota:
il condensatore sarà fornito a corredo

Note:
the capacitor will be supplied separately

AC

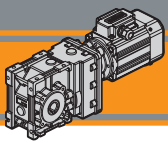

CMB

Motoriduttori CA ad assi ortogonali
AC Helical bevel gearmotors

MINI TECNO

CMB402/ F... Flange uscita / Output flanges

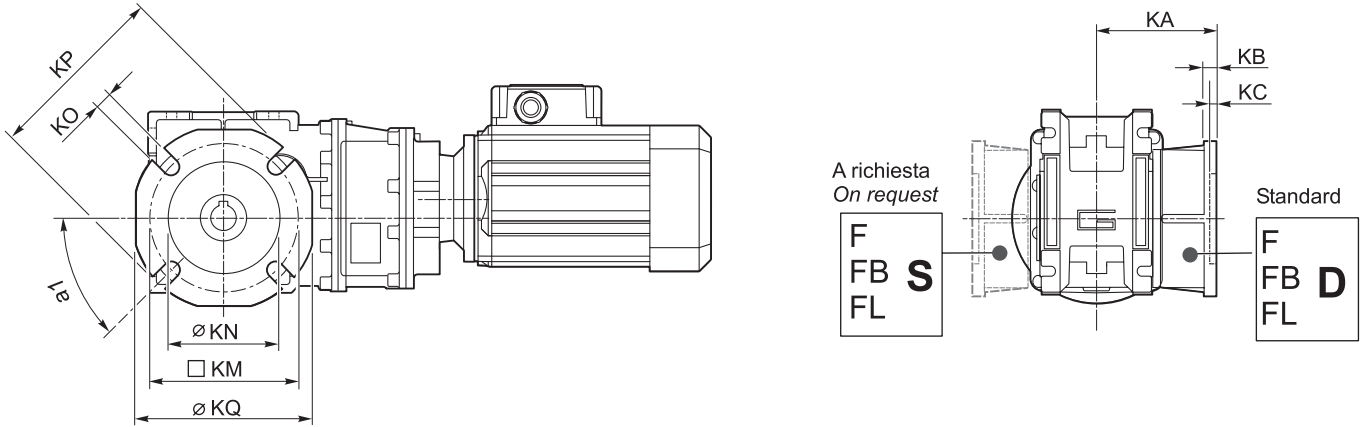

CMB	Flange uscita / Output flanges																										
	F								FL								FB										
	a ₁	KA	KB	KC	KM	KN H8	KO	KP	KQ	a ₁	KA	KB	KC	KM	KN H8	KO	KP	KQ	a ₁	KA	KB	KC	KM	KN H8	KO	KP	KQ
402	45°	67	7.5	4.5	80-95	60	9	110	95	45°	97	7.5	4.5	80-95	60	9	110	95	45°	80	8.5	5	115-125	95	9.5	140	112

Accessori

Accessories

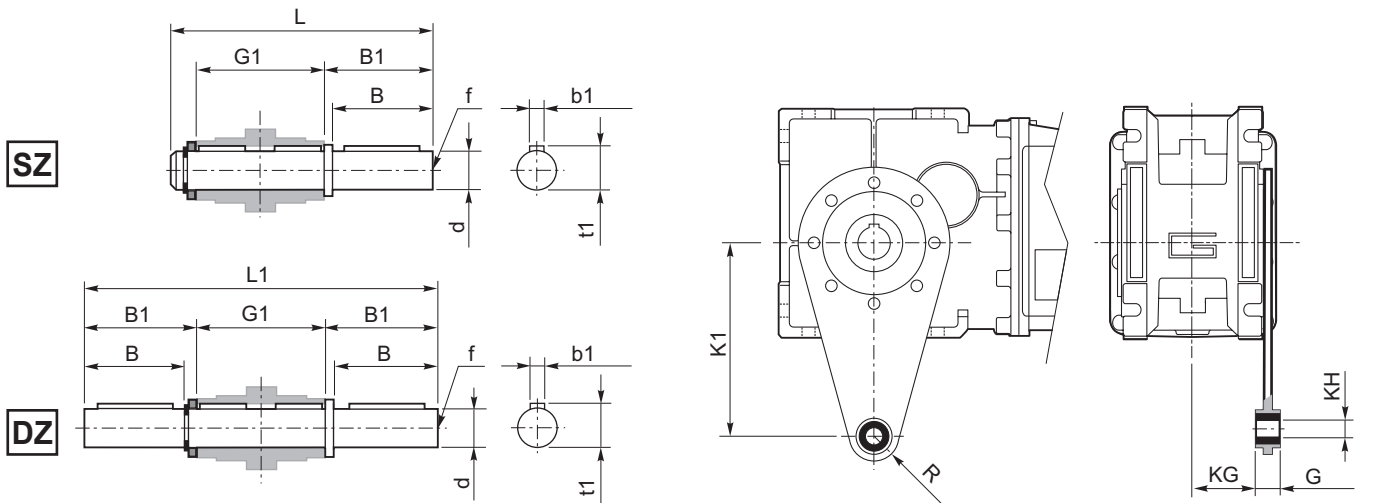

Albero lento / Output shaft

CMB	d h7	B	B1	G1	L	L1	f	b1	t1
402	18	40	43	78	128	164	M6	6	20.5

Braccio di reazione / Torque arm

CMB	K1	G	KG	KH	R
402	100	14	31	10	18

SC - Safety cover

WD - Kit washdown cover

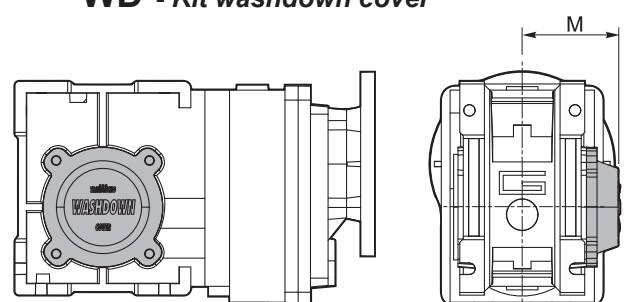
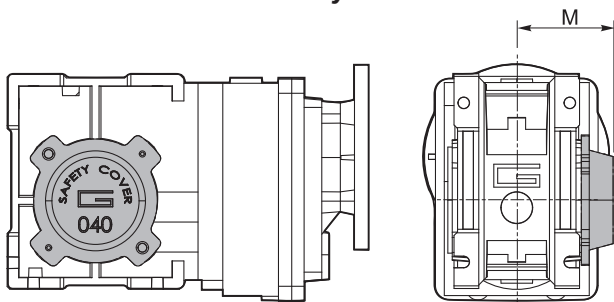

CMB	M
402	54.5

CMB	M
402	55.5

MINI  **TECNO**™
small but strong

KFT105 - FT

Motoriduttori CA pendolari
AC Helical parallel gearmotors

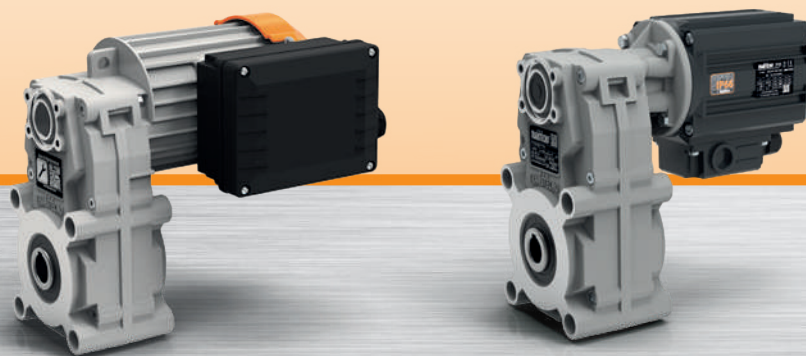

MINI  **TECNO**™ brand of
TRANSTECNO®



AC

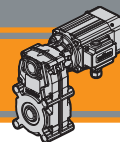

Indice	Index	Pag. Page
Caratteristiche tecniche	<i>Technical features</i>	AG2
Designazione	<i>Classification</i>	AG2
Sensi di rotazione	<i>Direction of rotation</i>	AG3
Simbologia	<i>Symbols</i>	AG3
Lubrificazione	<i>Lubrication</i>	AG3
Carichi radiali	<i>Radial loads</i>	AG4
Motori applicabili	<i>Motor adapters</i>	AG4
Dati tecnici	<i>Technical data</i>	AG5
Dati tecnici elettrici	<i>Electrical technical data</i>	AG7
Normative di riferimento	<i>Reference standards</i>	AG7
Dimensioni	<i>Dimensions</i>	AG8

Questa sezione annulla e sostituisce ogni precedente edizione o revisione. Qualora questa sezione non Vi sia giunta in distribuzione controllata, l'aggiornamento dei dati ivi contenuto non è assicurato. **In tal caso la versione più aggiornata è disponibile sul nostro sito internet www.transtecno.com**

This section replaces any previous edition and revision. If you obtained this catalogue other than through controlled distribution channels, the most up to date content is not guaranteed. In this case the latest version is available on our web site www.transtecno.com

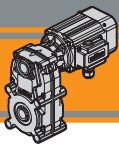

**KFT105
FT**

**Motoriduttori CA pendolari
AC Helical parallel gearmotors**



Caratteristiche tecniche

Technical features

Le caratteristiche principali dei motoriduttori KFT e FT sono:

KFT and FT gearmotor range has the following main features:

- Costruzione compatta
- Motorizzazioni in corrente alternata monofase e trifase
- Carcassa motore SMT e SMM estrusa in alluminio anodizzato nero
- Carcasse dei riduttori in pressofusione di alluminio
- Motore elettrico SMT e SMM con grado di protezione IP66
- Lubrificazione permanente con olio sintetico
- Ingranaggi cilindrici a denti elicoidali, induriti e rettificati
- Disponibili sia nella versione ventilata TEFC (servizio S1) che non ventilata TENV (servizio S3)
- Protezione termica PTO 150°C per la taglia motore 56.
- SMT56 adatto al funzionamento con alimentazione da inverter
- SMT e SMM Disponibili nelle versioni autofrenante, servoven-tilata e con certificazione UL.
- Versione KFT105 con motore monofase integrato

- *Compact design*
- *AC single phase and three phase motors available*
- *SMT and SMM motors extruded aluminum housing black ano-dized*
- *Gearbox die-cast aluminum housing*
- *SMT and SMM electric motors in IP66 protection Standard*
- *Permanent synthetic oil long-life lubrication*
- *Ground-hardened helical gears*
- *Fan cooled TEFC (duty S1) and not ventilated TENV (duty S3) versions available*
- *PTO 150°C thermal protection for motor size 56.*
- *SMT56 is suitable for inverter duty*
- *Brake motors, forced ventilation motors and UL compliance versions available for SMT and SMM motors.*
- *KFT105 version with integrated single motor phase*

KFT105

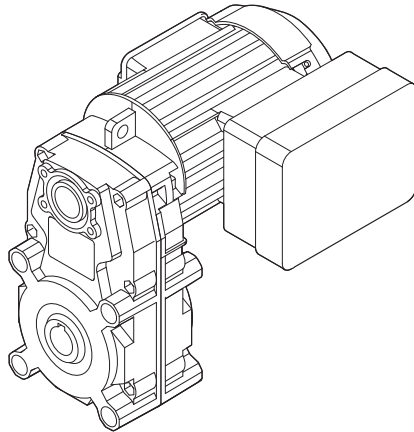

FT105

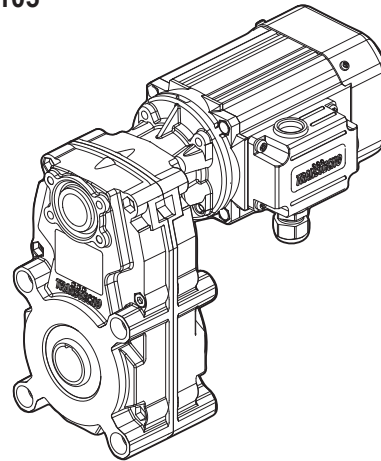

Designazione

Classification

RIDUTTORE / GEARBOX				
KFT	105/3	U	88.87	O20
Tipo Type	Grandezza Size	Versione Version	Rapporto Ratio	Albero cavo uscita Hollow output shaft
KFT 	105/3 105/4	U... F...	vedi tabelle see tables	vedi tabelle see tables

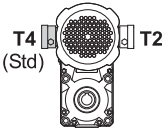
MOTORE / MOTOR						
40W	4p	3ph	230/400V	50Hz	T1	TEFC
Potenza Power	Poli Poles	Fasi Phases	Tensione Voltage	Frequenza Frequency	Pos. morsetti- Terminal box pos.	Ventilazione Fan cooling
vedi tabelle see tables	4p	1ph 3ph	230V ... 230/400V ...	50Hz 60Hz		TEFC TENV

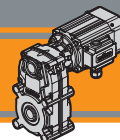
Designazione
Classification

RIDUTTORE / GEARBOX						
FT	105/3	U	77.07	O20	56	B14
Tipo Type	Grandezza Size	Versione Version	Rapporto Ratio	Albero cavo uscita Hollow output shaft	IEC 	Forma costruttiva Version
FT 	105/3 105/4	U...	vedi tabelle see tables	vedi tabelle see tables	56	B14

MOTORE TRIFASE / THREE PHASE MOTOR										
SMT	56	4	4	0.18 kW	B14	230-400 V	50 Hz	TEFC	BR	T1
Tipo Type	Grandezza Size	Indicativo potenza Power coefficient	Poli Poles	Potenza Power	Forma costruttiva Version	Tensione Voltage	Frequenza Frequency	Ventilazione Fan cooling	Opzioni Options	Pos. Morsettiera Terminal box pos.
SMT 	Vedere tab. See tab.	1-2-3-4-5	4	0.04 kW ... 0.25 kW	B14	230-400 V 460V	50Hz 60Hz	TEFC TENV	 AB1 AC1 AD1	T1 (Std) T4 T2 T3

MOTORE MONOFASE / SINGLE PHASE MOTOR										
SMM	56	4	4	0.18 kW	B14	230 V	50 Hz	TEFC	UL-CSA	T1
Tipo Type	Grandezza Size	Indicativo potenza Power coefficient	Poli Poles	Potenza Power	Forma costruttiva Version	Tensione Voltage	Frequenza Frequency	Ventilazione Fan cooling	Opzioni Options	Pos. Morsettiera Terminal box pos.
SMM 	Vedere tab. See tab.	1-2-3-4	4	0.04 kW ... 0.18 kW	B14	230V	50Hz	TEFC TENV	 AD1	T1 (Std) T4 T2 T3

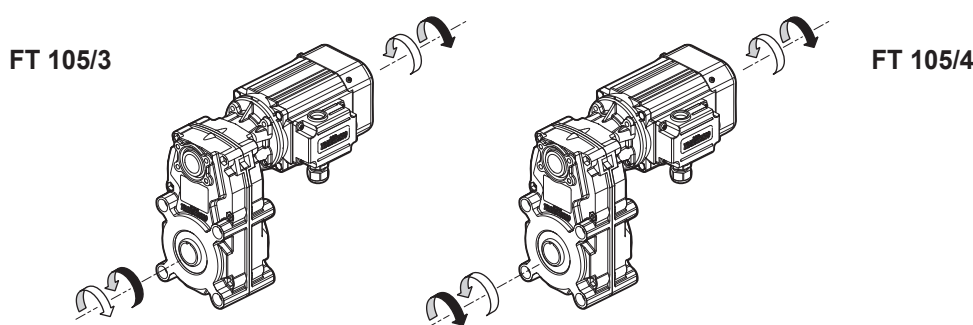
Sensi di rotazione
Direction of rotation

Simbologia
Symbols

n_1	[min^{-1}]	Velocità in ingresso / <i>Input speed</i>
n_2	[min^{-1}]	Velocità in uscita / <i>Output speed</i>
i		Rapporto di riduzione / <i>Ratio</i>
P_1	[kW]	Potenza in entrata / <i>Input power</i>
M_2	[Nm]	Coppia nominale in uscita in funzione di P_1 / <i>Output torque referred to P_1</i>
P_{n1}	[kW]	Potenza nominale in entrata / <i>Nominal input power</i>
M_{n2}	[Nm]	Coppia nominale in uscita in funzione di P_{n1} / <i>Nominal output torque referred to P_{n1}</i>
sf		Fattore di servizio / <i>Service factor</i>
R_2	[N]	Carico radiale ammissibile in uscita / <i>Permitted output radial load</i>
A_2	[N]	Carico assiale ammissibile in uscita / <i>Permitted output axial load</i>

Lubrificazione
Lubrication

Tutti i motoriduttori sono forniti completi di lubrificante sintetico viscosità 320, pertanto possono essere installati in qualunque posizione di montaggio e non necessitano di manutenzione.

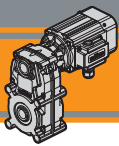
Permanent synthetic oil long-life lubrication (viscosity grade 320) makes it possible to use the gearmotors in all mounting positions; for this reason they can be installed in any assembly position and do not require maintenance.



**KFT105
FT**

**Motoriduttori CA pendolari
AC Helical parallel gearmotors**



Carichi radiali

Radial loads

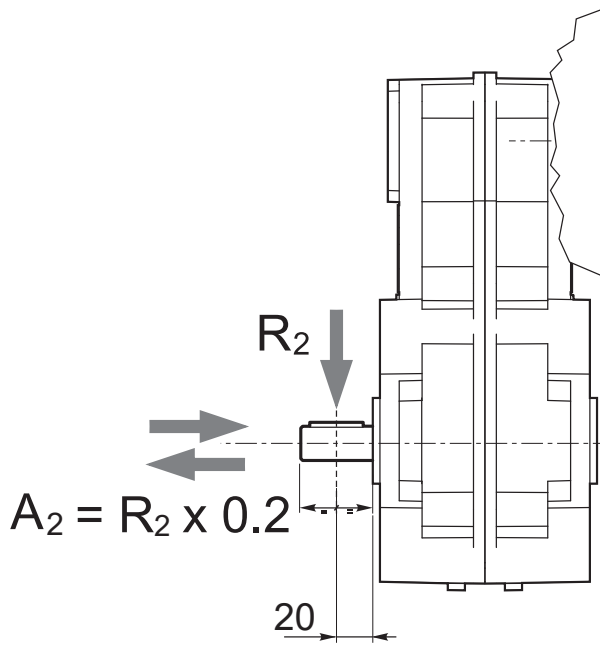

n_2 [min ⁻¹]	R_2 [N]
	KFT105 FT105
70	1500
40	1700
30	1850
20	2000
10	2000
5	2000

Quando il carico radiale risultante non è applicato sulla mezzesfera dell'albero occorre calcolare quello effettivo con la seguente formula:

When the resulting radial load is not applied on the centre line of the shaft it is necessary to calculate the effective load with the following formula:

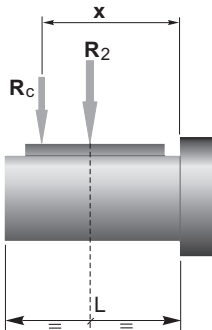

	KFT105 FT105
a	82
b	62
R_{2MAX}	2000

$$R_c = \frac{R_2 \cdot a}{(b + x)} \leq R_{2MAX}$$

a, b = valori riportati nella tabella
a, b = values given in the table

$$R \leq R_c$$

Motori applicabili

IEC Motor adapters

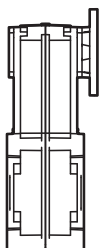
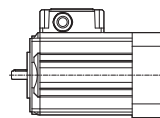

		SMT		SMM	
		5014	5624	5014	5624
		5024	5634	5024	5634
		5034	5644	5034	5644
		5044	5654		
FT	105/3	20.57 - 315.05			
FT	105/4	368.19 - 929.4			

20.57 - 929.4

Rapporti di riduzione i
Ratio i

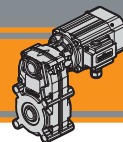

Dati tecnici

Technical data

P ₁ [kW]	n ₂ [min ⁻¹]	M ₂ [Nm]	sf	M _n [Nm]	i	
------------------------	--	------------------------	----	------------------------	---	--

P ₁ [kW]	n ₂ [min ⁻¹]	M ₂ [Nm]	sf	M _n [Nm]	i	
------------------------	--	------------------------	----	------------------------	---	--

0.025

68	3	12.1	40	20.57	KFT105/3
42	5	9.4	50	33.32	
32	7	9.1	65	44.36	
26	9	7.4	65	54.87	
19	12	5.6	65	71.84	
18	12	5.3	65	77.07	
16	14	4.6	65	88.87	
11	20	3.2	65	124.81	
7.7	29	2.2	65	181.35	
6.2	36	1.8	65	224.32	
4.4	51	1.3	65	315.05	
3.8	58	1.1	65	368.19	KFT105/4
2.6	84	0.8	65	534.98	
2.1	104	0.6	65	661.76	
1.5	120	0.5	65	929.40	

0.09

68	12	3.4	40	20.57	KFT105/3
42	19	2.6	50	33.32	
32	26	2.5	65	44.36	
26	32	2.1	65	54.87	
19	41	1.6	65	71.84	
18	44	1.5	65	77.07	
16	51	1.3	65	88.87	
11	72	0.9	65	124.81	
7.7	105	0.6	65	181.35	
6.2	110	0.6	65	224.32	

0.04

68	5	7.6	40	20.57	KFT105/3
42	9	5.9	50	33.32	
32	11	5.7	65	44.36	
26	14	4.6	65	54.87	
19	18	3.5	65	71.84	
18	20	3.3	65	77.07	
16	23	2.9	65	88.87	
11	32	2.0	65	124.81	
7.7	47	1.4	65	181.35	
6.2	58	1.1	65	224.32	
4.4	81	0.8	65	315.05	
3.8	92	0.7	65	368.19	KFT105/4
2.6	120	0.5	65	534.98	
2.1	120	0.5	65	661.76	

0.12

68	16	2.5	40	20.57	KFT105/3
42	26	2.0	50	33.32	
32	34	1.9	65	44.36	
26	42	1.5	65	54.87	
19	55	1.2	65	71.84	
18	59	1.1	65	77.07	
16	68	1.0	65	88.87	
11	96	0.7	65	124.81	
7.7	110	0.6	65	181.35	

0.06

68	8	5.1	40	20.57	KFT105/3
42	13	3.9	50	33.32	
32	17	3.8	65	44.36	
26	21	3.1	65	54.87	
19	28	2.4	65	71.84	
18	30	2.2	65	77.07	
16	34	1.9	65	88.87	
11	48	1.4	65	124.81	
7.7	70	0.9	65	181.35	
6.2	86	0.8	65	224.32	
4.4	110	0.6	65	315.05	
3.8	120	0.5	65	368.19	KFT105/4

N.B.

Verificare sempre che la coppia M₂ utilizzata non ecceda il valore indicato nelle caselle in grigio

N.B.

Please check that the output torque M₂ does not exceed the value in the grey areas

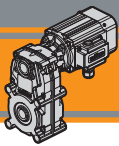
**FT****Motoriduttori CA pendolari**
AC Helical parallel gearmotors**Dati tecnici****Technical data**

P ₁ [kW]	n ₂ [min ⁻¹]	M ₂ [Nm]	sf	i	
0.04					
SMT5014	68	5	7.6	20.57	FT105/3
SMM5014	42	9	5.9	33.32	
(1400 min ⁻¹)	32	11	5.7	44.36	
	26	14	4.6	54.87	
	19	18	3.5	71.84	
	18	20	3.3	77.07	
	16	23	2.9	88.87	
	11	32	2.0	124.81	
	7.7	47	1.4	181.35	
	6.2	58	1.1	224.32	
	4.4	81	0.8	315.05	
	3.8	92	0.7	368.19	FT105/4
	2.6	120	0.5	534.98	
	2.1	120	0.5	661.76	

P ₁ [kW]	n ₂ [min ⁻¹]	M ₂ [Nm]	sf	i	
0.12					
SMT5044	68	16	2.5	20.57	FT105/3
SMT5634	42	26	2.0	33.32	
SMM5624	32	34	1.9	44.36	
(1400 min ⁻¹)	26	42	1.5	54.87	
	19	55	1.2	71.84	
	18	59	1.1	77.07	
	16	68	1.0	88.87	
	11	96	0.7	124.81	
	7.7	110	0.6	181.35	

P ₁ [kW]	n ₂ [min ⁻¹]	M ₂ [Nm]	sf	i	
0.06					
SMT5024	68	8	5.1	20.57	FT105/3
SMM5024	42	13	3.9	33.32	
(1400 min ⁻¹)	32	17	3.8	44.36	
	26	21	3.1	54.87	
	19	28	2.4	71.84	
	18	30	2.2	77.07	
	16	34	1.9	88.87	
	11	48	1.4	124.81	
	7.7	70	0.9	181.35	
	6.2	86	0.8	224.32	
	4.4	92	0.7	315.05	

P ₁ [kW]	n ₂ [min ⁻¹]	M ₂ [Nm]	sf	i	
0.18					
SMT5644	68	24	1.7	20.57	FT105/3
SMM5644	42	38	1.3	33.32	
(1400 min ⁻¹)	32	51	1.3	44.36	
	26	63	1.0	54.87	
	19	83	0.8	71.84	
	18	89	0.7	77.07	
	16	92	0.7	88.87	
	11	110	0.6	124.81	

P ₁ [kW]	n ₂ [min ⁻¹]	M ₂ [Nm]	sf	i	
0.25					
SMT5654	68	33	1.2	20.57	FT105/3
(1400 min ⁻¹)	42	53	0.9	33.32	
	32	71	0.9	44.36	

P ₁ [kW]	n ₂ [min ⁻¹]	M ₂ [Nm]	sf	i	
0.09					
SMT5034	68	12	3.4	20.57	FT105/3
SMM5034	42	19	2.6	33.32	
SMT5624	32	26	2.5	44.36	
SMM5624	26	32	2.1	54.87	
(1400 min ⁻¹)	19	41	1.6	71.84	
	18	44	1.5	77.07	
	16	51	1.3	88.87	
	11	72	0.9	124.81	
	7.7	105	0.6	181.35	
	6.2	110	0.6	224.32	

N.B.
Verificare sempre che la coppia M₂ utilizzata non ecceda il valore indicato nelle caselle in grigio
N.B.
Please check that the output torque M₂ does not exceed the value in the grey areas



Motori Motors	SMT		SMM	
		5014 5024 5034 5044	5624 5634 5644 5654	5014 5024 5034
IEC	56 B14		56 B14	

Dati tecnici elettrici**Electrical technical data**

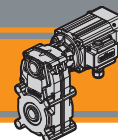
Dati tecnici elettrici - KFT 105
KFT 105 - Electrical technical data

1 Ph	P _n [W]	V [V]	F [Hz]	I _n [A]	I _s [A]	cosØ	C [µF]	TEFC Servizio Duty	TENV Servizio Duty
	25	230	50	0.42	0.84	0.87	6.0	S1 100%	S3 30%
	40			0.47	0.86	0.91	6.3		
	60			0.74	1.50	0.82	8.0		
	90			0.82	1.60	0.93	12.5		
	120			1.38	3.10	0.81	14.0		

3 Ph	P _n [W]	V [V]	F [Hz]	I _n [A]	I _s [A]	cosØ	TEFC Servizio Duty	TENV Servizio Duty
	25	230	50	0.41	0.97	0.54	S1 100%	S3 30%
		400						
	40	230	50	0.43	0.97	0.62		
		400						
	60	230	50	0.72	1.80	0.48		
		400						
	90	230	50	0.74	1.80	0.60		
		400						
	120	230	50	1.34	3.70	0.50		
		400						

Nota:

Classe di rendimento Standard IE1

Note:

Standard efficiency IE1

Normative di riferimento
Reference standards

	Europe EN	World IEC	Italy CEI
Requisiti generali per macchine elettriche <i>General requirements electrical machines</i>	EN 60034-1:2010	IEC 60034-1:2010	CEI EN 60034-1:2010
Classificazione del grado di protezione <i>Classification degree of protection provided by enclosures</i>	EN 60034-5:2001	IEC 60034-5:2001	CEI EN 60034-5:2001
Sistema di raffreddamento <i>Cooling system</i>	EN 60034-6:1993	IEC 60034-6:1993	CEI EN 60034-6:1993
Modalità di montaggio <i>Mounting arrangements</i>	EN 60034-7:1993	IEC 60034-7:1993	CEI EN 60034-7:1993

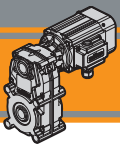

Dimensioni

Dimensions

KFT 105... 25W - 40W - 60W - 90W

KFT 105...1 Ph...TEFC

KFT 105...1 Ph...TENV

S3 servizio duty 30%

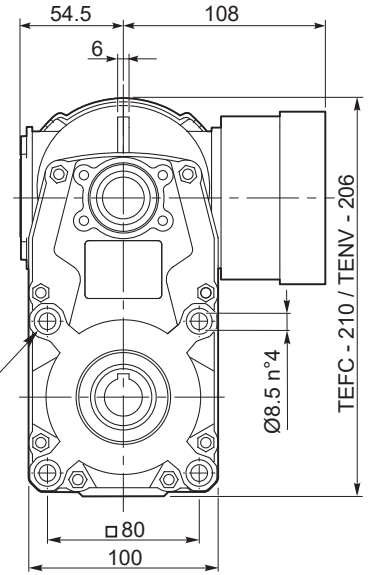
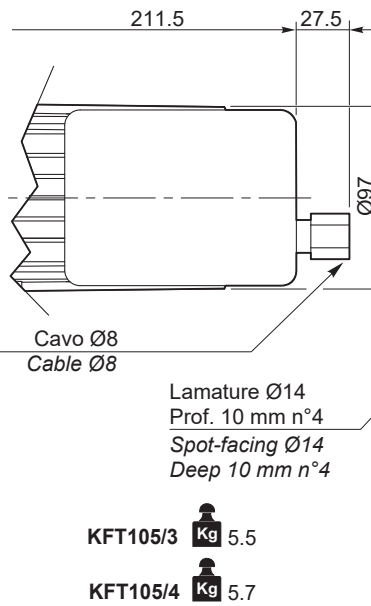
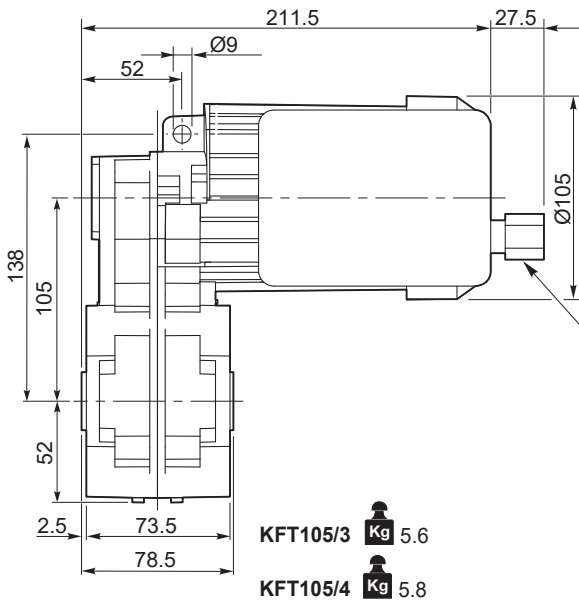

NOTA: Stessi fissaggi da entrambi i lati
NOTE: Same fixing points in both sides

KFT 105...3 Ph... TEFC

KFT 105...3 Ph... TENV

S3 servizio duty 30%

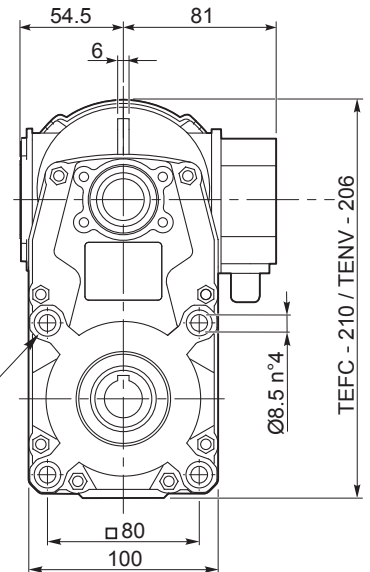
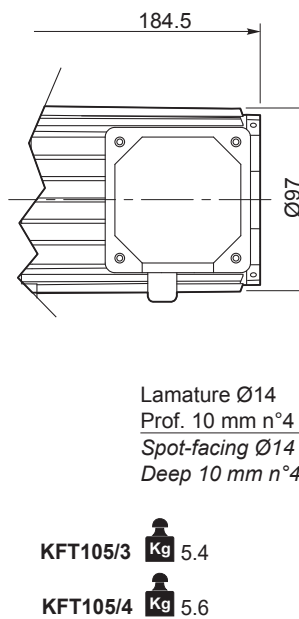
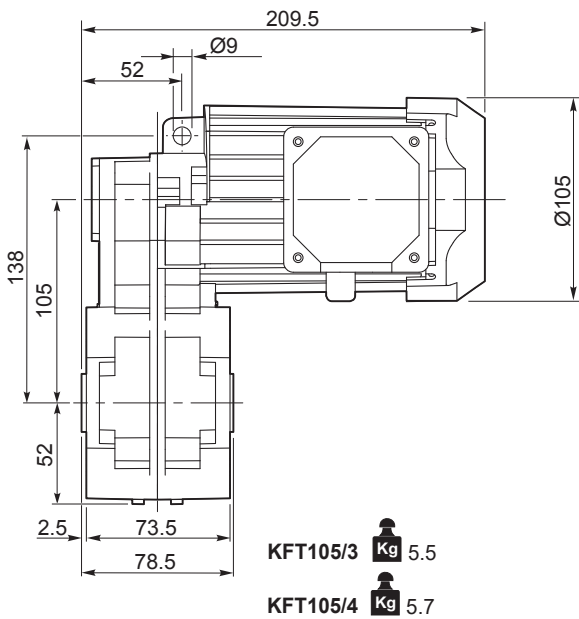

NOTA: Stessi fissaggi da entrambi i lati
NOTE: Same fixing points in both sides

O17

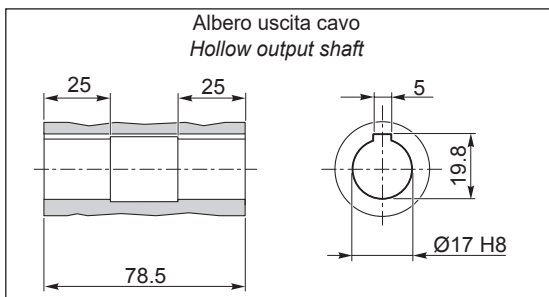

O20

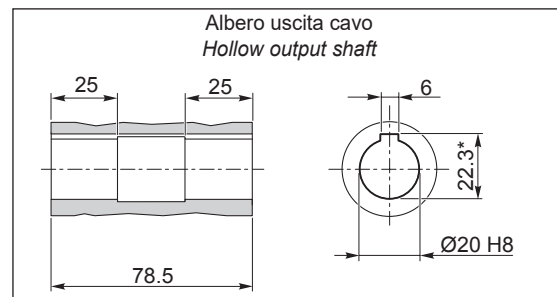

*Sede linguetta ribassata / Special Keyway

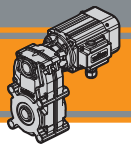

Dimensioni

Dimensions

KFT 105... 120W

KFT 105...1 Ph... TEFC

KFT 105...1 Ph...TENV S3 servizio duty 30%

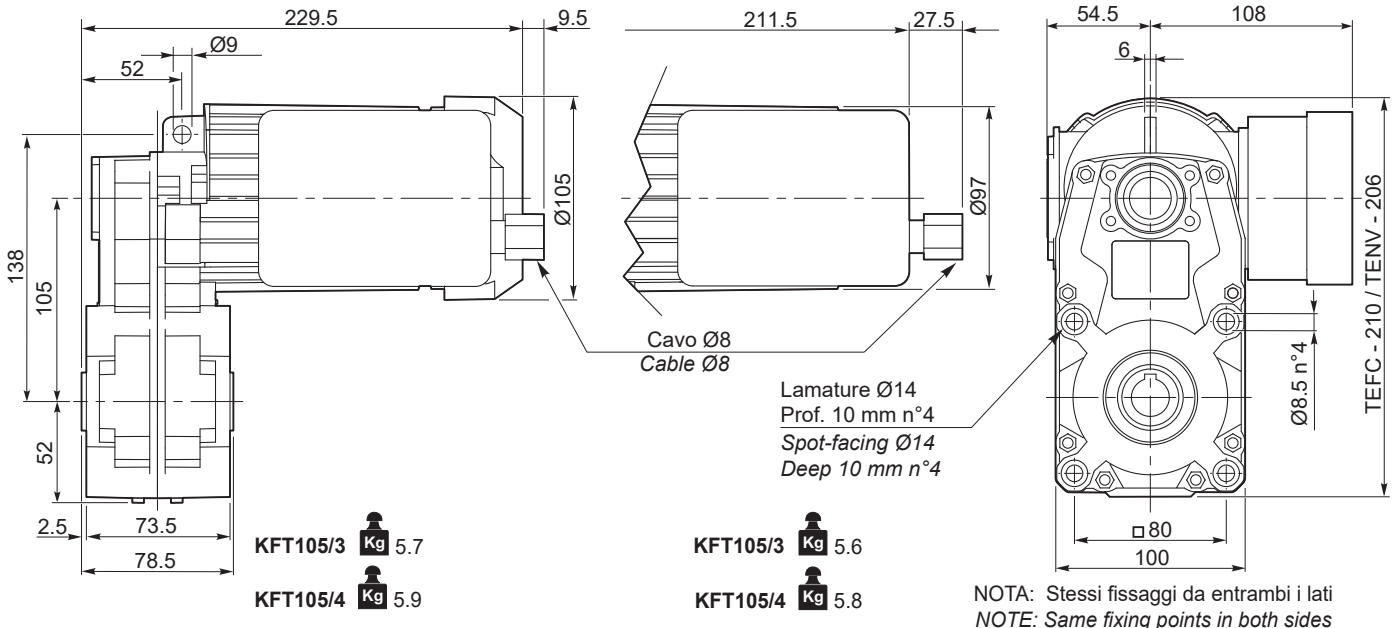

KFT 105...3 Ph... TEFC

KFT 105...3 Ph... TENV S3 servizio duty 30%

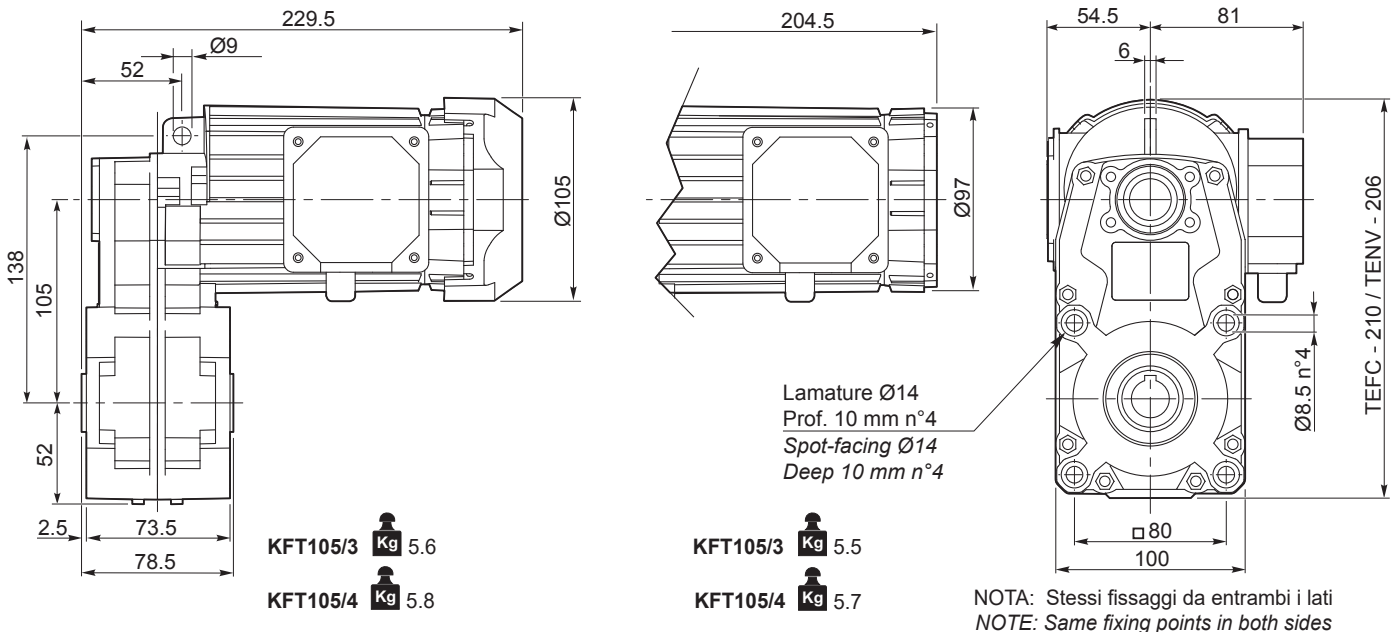

O17

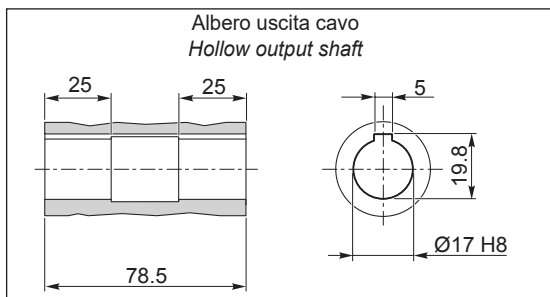

O20

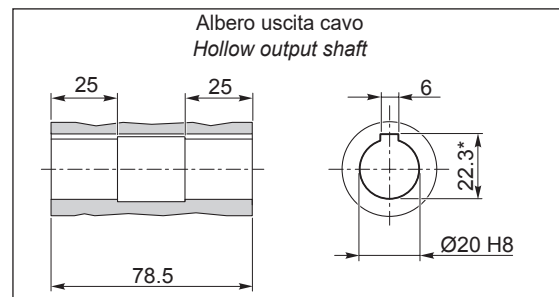

*Sede linguetta ribassata/ Special Keyway

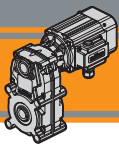
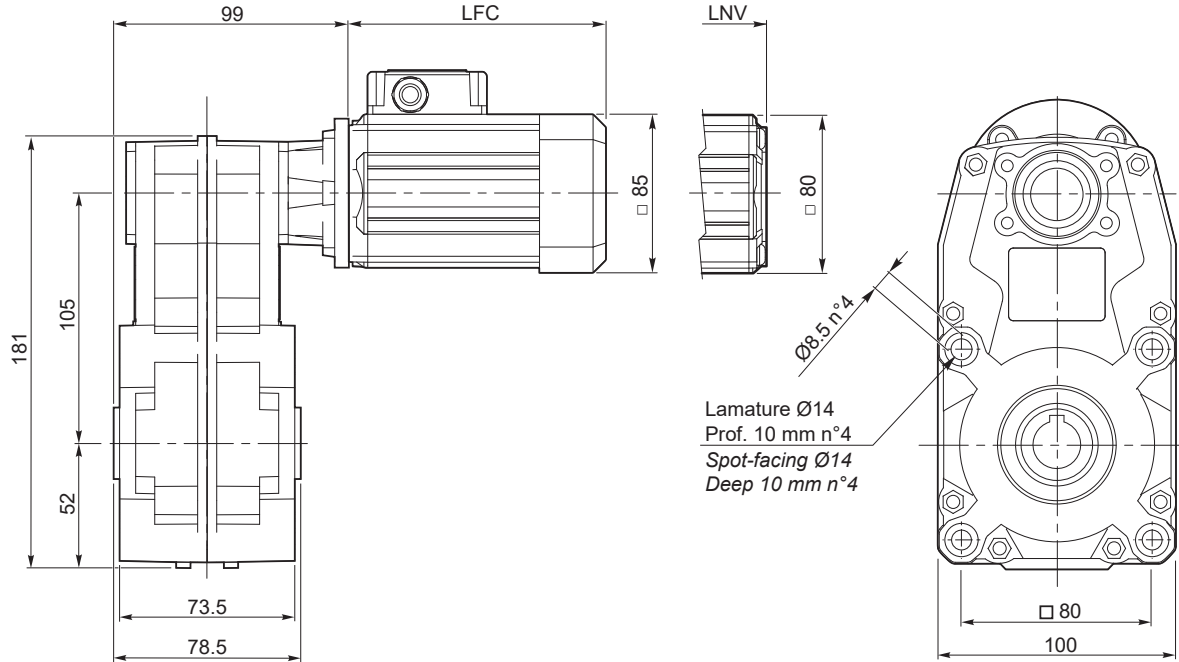
**FT****Motoriduttori CA pendolari
AC Helical parallel gearmotors****MINI
TECNO****Dimensioni****Dimensions****FT105 U****FT 105...U****SMT50...TEFC
SMM50... TEFC****SMT50...TENV
SMM50... TENV****S3 servizio 30%**
duty

NOTA: Stessi fissaggi da entrambi i lati
NOTE: Same fixing points in both sides

SMT	LFC	LNV	Kg	
5014	135.5	108.5	6.5	
5024	150.5	123.5	6.9	
5034	175.5	148.5	7.7	
5044	200.5	173.5	8.4	

SMM	LFC	LNV	Kg	
5014	150.5	123.5	6.9	
5024	175.5	148.5	7.7	
5034	200.5	173.5	8.4	

Nota:

il condensatore sarà fornito a corredo

Note:

the capacitor will be supplied separately

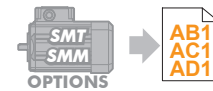
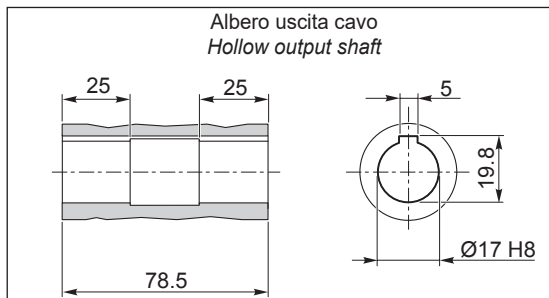
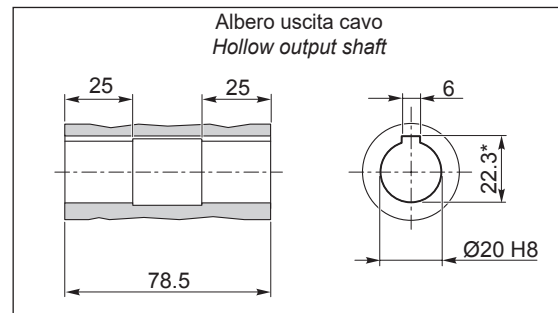
**O17****O20**

*: Sede linguetta ribassata / Special keyway

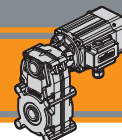

Dimensioni

Dimensions

FT105 U

FT 105...U

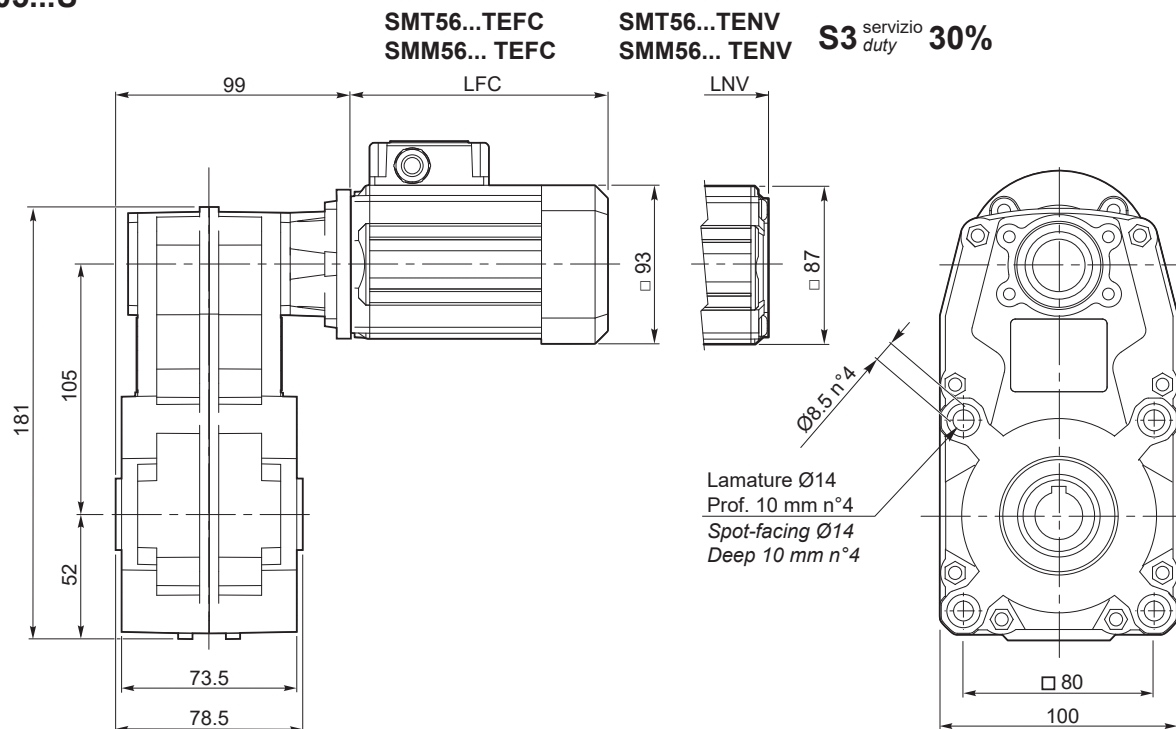

NOTA: Stessi fissaggi da entrambi i lati
NOTE: Same fixing points in both sides

SMT	LFC	LNV	Kg	
5624	141	117	7	
5634	151	127	7.4	
5644	186	162	8.6	
5654	206	182	9.3	

SMM	LFC	LNV	Kg	
5624	151	127	7.3	
5634	171	147	7.9	
5644	206	182	9.2	

Nota:
il condensatore sarà fornito a corredo
Note:
the capacitor will be supplied separately



O17

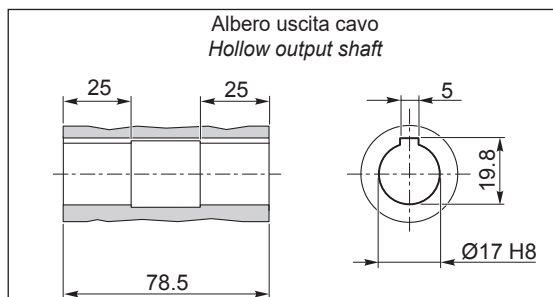

O20

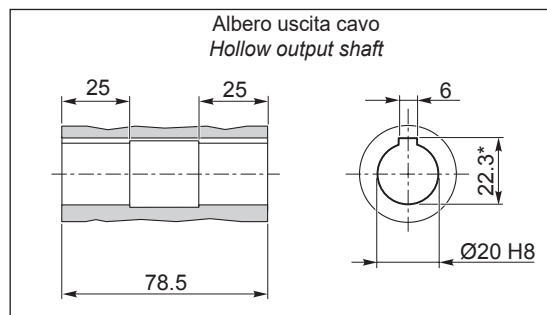

*: Sede linguetta ribassata / Special keyway

MINI  **TECNO**™
small but strong

CM-CMP

Motoriduttori CA a vite senza fine
AC Wormgearmotors

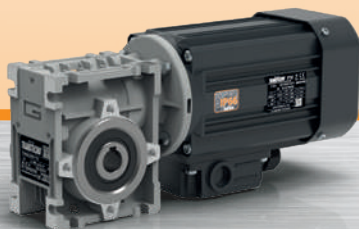

MINI  **TECNO**™ brand of
TRANSTECNO®



AC

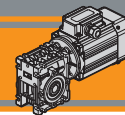

Indice	Index	Pag. Page
Caratteristiche tecniche	<i>Technical features</i>	AH2
Designazione	<i>Classification</i>	AH3
Sensi di rotazione	<i>Direction of rotation</i>	AH4
Simbologia	<i>Symbols</i>	AH4
Lubrificazione	<i>Lubrication</i>	AH4
Carichi radiali	<i>Radial loads</i>	AH5
Dati di dentatura	<i>Toothing data</i>	AH5
Rendimento	<i>Efficiency</i>	AH6
Motori applicabili	<i>Motor adapters</i>	AH6
Dati tecnici	<i>Technical</i>	AH7
Dimensioni	<i>Dimensions</i>	AH10
Opzioni	<i>Options</i>	AH20
Accessori	<i>Accessories</i>	AH20

Questa sezione annulla e sostituisce ogni precedente edizione o revisione. Qualora questa sezione non Vi sia giunta in distribuzione controllata, l'aggiornamento dei dati ivi contenuto non è assicurato. **In tal caso la versione più aggiornata è disponibile sul nostro sito internet www.transtecno.com**

This section replaces any previous edition and revision. If you obtained this catalogue other than through controlled distribution channels, the most up to date content is not guaranteed. In this case the latest version is available on our web site www.transtecno.com

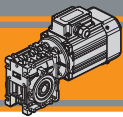

CM
CMP

Caratteristiche tecniche

Technical features

Le caratteristiche principali dei motoriduttori CM e CMP sono:

- Costruzione compatta
- Motorizzazioni in corrente alternata monofase e trifase
- Carcassa motore estrusa in alluminio anodizzato nero
- Carcasse dei riduttori in pressofusione di alluminio
- Motore elettrico AC con grado di protezione IP66
- Lubrificazione permanente con olio sintetico
- Disponibili sia nella versione ventilata TEFC (servizio S1) che non ventilata TENV (servizio S3)
- Protezione termica PTO 150°C per le taglie motore 56, 63 e 71.
- SMT56, SMT63 e SMT71 adatti al funzionamento con alimentazione da inverter
- Disponibili nelle versioni autofrenante, servovenilata e con certificazione UL.

CM and CMP gearmotors range has the following main features:

- Compact design
- AC single phase and three phase motors available
- Motor extruded aluminum housing black anodized
- Gearbox die-cast aluminum housing
- AC electric motor in IP66 protection Standard
- Permanent synthetic oil long-life lubrication
- Fan cooled TEFC (duty S1) and not ventilated TENV (duty S3) versions available
- PTO 150°C thermal protection for motor sizes 56, 63 and 71.
- SMT56, SMT63 and SMT71 are suitable for inverter duty
- Brake motors, forced ventilation motors and UL compliance versions available.

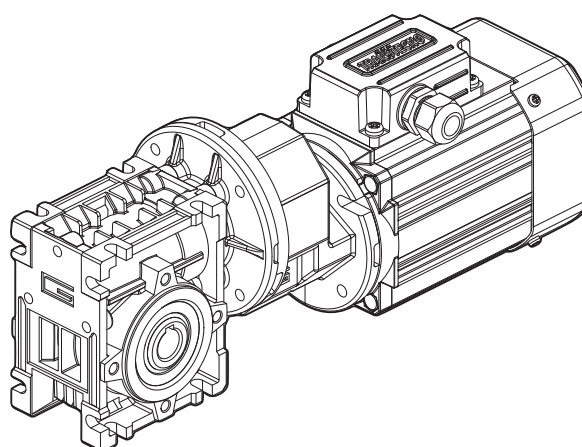
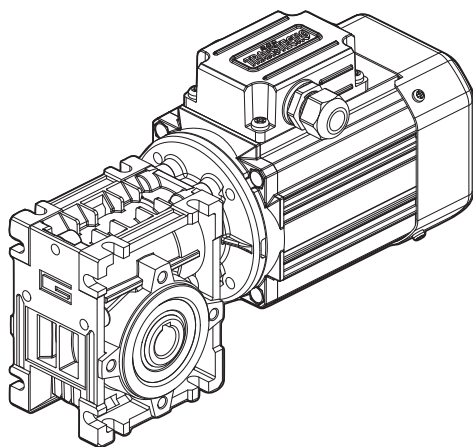

Designazione

Classification

RIDUTTORI A VITE SENZA FINE / WORMGEARBOXES

RIDUTTORE / GEARBOX									
CM	040	U	10	63	B14	SZDX	BRSX	90	VS
Tipo Type	Grandezza Size	Versione riduttore Gearbox Version	Rapporto Ratio	IEC 	Forma costruttiva Version	Albero di uscita Output shaft	Braccio di reazione Torque arm	Angolo Angle	Opzioni Options
	026 026 (D11) 026 (D14) 030 040	U F...	Vedere tabella <i>See tables</i>	56.. 63.. 71..	B14	SZDX SZSX DZ	BRDX BRSX *	0° 90° 180° 270°	VS

RIDUTTORI A VITE SENZA FINE CON PRECOPPIA / PRE-STAGE WORMGEARBOXES

RIDUTTORE / GEARBOX										
CMP	063/040	U	90	63	B14	SZDX	BRSX	90	P4	VS
Tipo Type	Grandezza Size	Versione Riduttore Gearbox Version	Rapporto Ratio	IEC 	Forma costruttiva Version	Albero di uscita Output shaft	Braccio di reazione Torque arm	Angolo Angle	Pos. di montaggio precoppia Pre stage mounting position	Opzioni Options
	056/030 056/040 063/040	U F...	Vedere tabella <i>See tables</i>	56.. 63..	B5 B14	SZDX SZSX DZ	BRDX BRSX *	0° 90° 180° 270°	P1 P2 P3 (standard) P4	VS

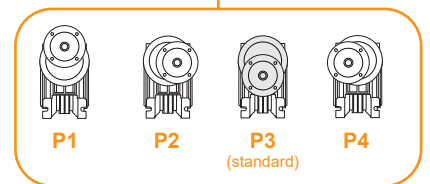

Versione Riduttore
Gearbox Version

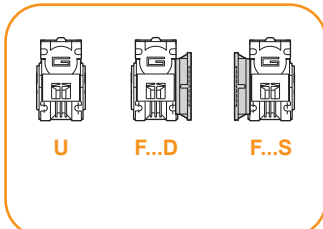

Albero di uscita
Output shaft

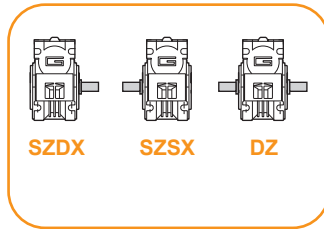

Braccio di reazione
Torque arm *

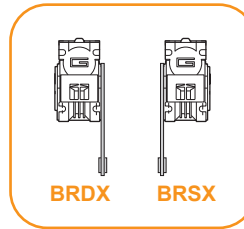

Angolo
Angle

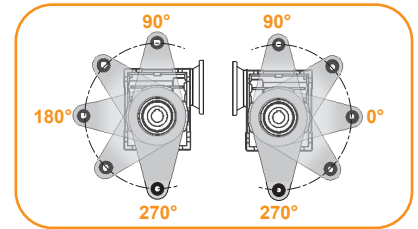

* NOTA: il braccio di reazione viene fornito smontato.
NOTE: the torque arm will be supplied not assembled.

MOTORE TRIFASE / THREE PHASE MOTOR

SMT	63	2	4	0.18 kW	B14	230-400 V	50 Hz	TEFC	BR	T1
Tipo Type	Grandezza Size	Indicativo potenza Power coefficient	Poli Poles	Potenza Power	Forma costruttiva Version	Tensione Voltage	Frequenza Frequency	Ventilazione Fan cooling	Opzioni Options	Pos. Morsettiera Terminal box pos.
	Vedere tab. <i>See tab.</i>	1-2-3-4-5	4	0.04 kW ... 0.75 kW	B14	230-400 V 460V	50Hz 60Hz	TEFC TENV		T1 (Std)

MOTORE MONOFASE / SINGLE PHASE MOTOR

SMM	63	2	4	0.18 kW	B14	230 V	50 Hz	TEFC	UL-CSA	T1
Tipo Type	Grandezza Size	Indicativo potenza Power coefficient	Poli Poles	Potenza Power	Forma costruttiva Version	Tensione Voltage	Frequenza Frequency	Ventilazione Fan cooling	Opzioni Options	Pos. Morsettiera Terminal box pos.
	Vedere tab. <i>See tab.</i>	1-2-3-4	4	0.04 kW ... 0.55 kW	B14	230V	50Hz	TEFC TENV		T1 (Std)

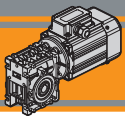

CM
CMP

Sensi di rotazione

Direction of rotation

CM

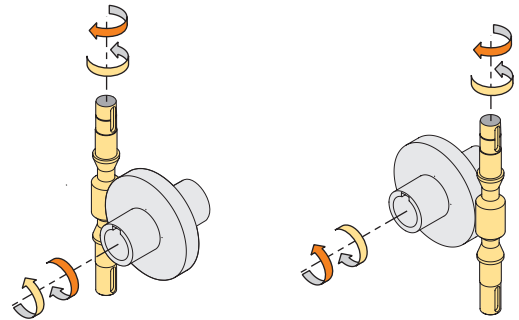
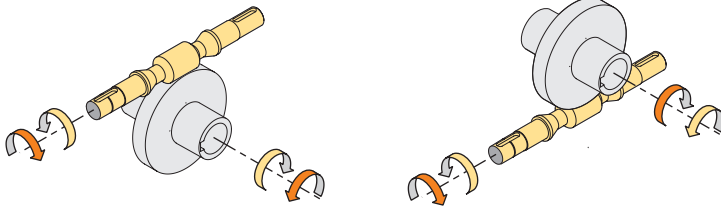

CMP

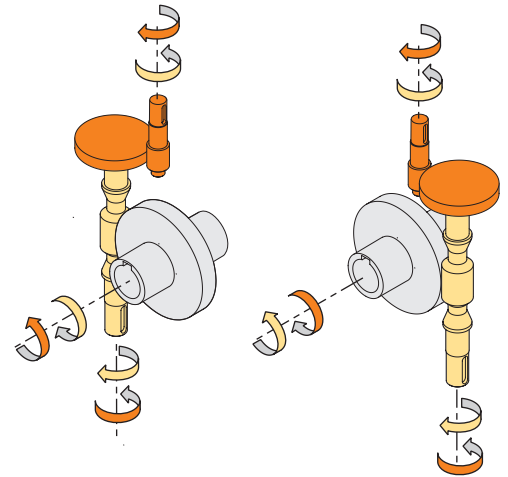
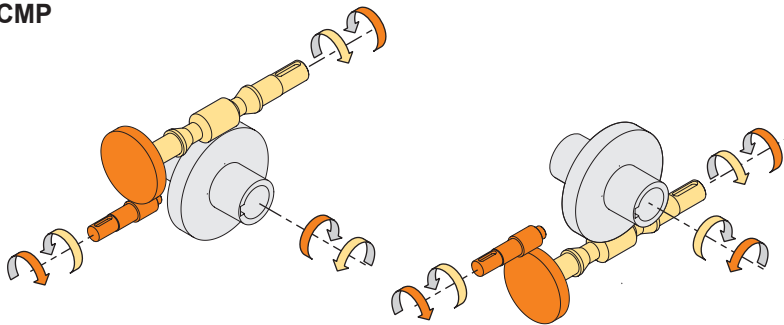

Simbologia

Symbols

n_1	[min^{-1}]	Velocità in ingresso / <i>Input speed</i>	R_d	%	Rendimento dinamico / <i>Dynamic efficiency</i>
n_2	[min^{-1}]	Velocità in uscita / <i>Output speed</i>	A_2	[N]	Carico assiale ammissibile in uscita / <i>Permitted output axial load</i>
i		Rapporto di riduzione / <i>Ratio</i>	R_s	%	Rendimento statico / <i>Static efficiency</i>
P_1	[kW]	Potenza in entrata / <i>Input power</i>	R_2	[N]	Carico radiale ammissibile in uscita / <i>Permitted output radial load</i>
M_2	[Nm]	Coppia in uscita in funzione di P_1 / <i>Output torque referred to P_1</i>	Z		Numero di principi della vite / <i>Worm starts</i>
sf		Fattore di servizio / <i>Service factor</i>	β		Angolo d'elica / <i>Helix angle</i>

Lubrificazione

Lubrication

I riduttori a vite senza fine della serie CM sono lubrificati a vita con olio sintetico di viscosità 320 e possono essere installati in qualunque posizione di montaggio.

Permanent synthetic oil long-life lubrication allow to use CM wormgearbox range in all mounting position.

Carichi radiali

Radial loads

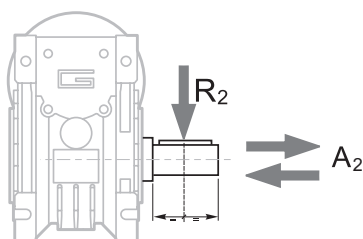

$$A_2 = R_2 \times 0.2$$

n ₂ [min ⁻¹]	R ₂ [N]		
	CM026	CM030	CM040
187	400	674	1264
140	490	743	1392
93	580	851	1596
70	610	936	1754
56	610	1008	1890
47	610	1069	2004
35	610	1179	2210
28	610	1270	2381
23	610	1356	2542
18	610	1471	2759
14	610	1600	3000
		CMP... /030	CMP... /040

Quando il carico radiale risultante non è applicato sulla mezza-
ria dell'albero occorre calcolare quello effettivo con la seguente
formula:

When the resulting radial load is not applied on the centre line
of the shaft it is necessary to calculate the effective load with the
following formula:

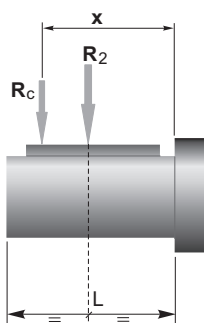

$$R_c = \frac{R_2 \cdot a}{(b + x)} \leq R_{2MAX}$$

$$R \leq R_c$$

a, b = valori riportati nella tabella
a, b = values given in the table

	CM	CM / CMP	
	026	030	040
a	56	65	84
b	43	50	64
R _{2MAX}	610	1600	3000

Dati di dentatura

Toothing data

	Dati della coppia vite- corona Worm wheel data	Rapporto / Ratio											
		5	7.5	10	15	20	25	30	40	50	60	80	100
CM026	Z	6	4	3	2	2		1	1	1	1		
	β	34° 35'	24° 41'	19° 1'	12° 57'	10° 30'		6° 33'	5° 17'	4° 26'	3° 49'		
CM030	Z	6	4	3	2	2	2	1	1	1	1	1	1
	β	27° 4'	24° 28'	18° 50'	12° 49'	10° 23'	8° 43'	6° 29'	5° 14'	4° 23'	3° 46'	2° 57'	2° 25'
CM040	Z	6	4	3	2	2	2	1	1	1	1	1	1
	β	34° 19'	24° 28'	18° 50'	12° 49'	10° 23'	8° 43'	6° 29'	5° 14'	4° 23'	3° 46'	2° 57'	2° 25'

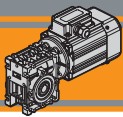

Rendimento

Efficiency

	n_1 [min ⁻¹]	Rendimento Efficiency	Rapporto / Ratio											
			5	7.5	10	15	20	25	30	40	50	60	80	100
CM026	2800	Rd	89	87	85	83	80		73	68	64	60		
	1400		87	84	83	78	74		66	61	57	53		
	900		84	83	80	75	71		61	57	52	48		
		Rs	72	71	68	61	56		46	41	36	34		
CM030	2800	Rd	89	88	86	84	81	78	74	70	65	62	57	52
	1400		86	85	84	79	75	72	67	62	58	55	48	43
	900		84	83	81	75	71	68	62	58	53	49	43	39
		Rs	72	67	63	55	50	43	39	35	31	27	23	21
CM040	2800	Rd	90	89	87	84	83	80	77	73	69	66	60	56
	1400		88	86	84	81	78	74	70	65	60	58	52	46
	900		86	84	82	77	74	70	66	60	57	53	46	41
		Rs	74	71	67	60	55	51	45	40	36	32	28	24



Rendimento teorico del riduttore dopo il rodaggio
Theoretical efficiency of the gearbox after the first running period

Motori applicabili

Motor adapters

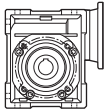
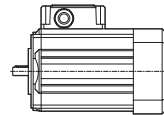

		SMT				SMM			
		5014 5024 5034 5044	5624 5634 5644 5654	6324 6334 6344	7124 7134 7144	5014 5024 5034	5624 5634 5644	6324 6334	7124 7134
CM	026	5 - 60				5 - 60			
	030	5 - 100		5-50		5 - 100		5-50	
	040	5 - 100			5-30	5 - 100			5-30

5 - 100

Rapporti di riduzione i
Ratio i

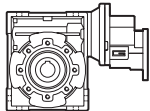

		SMT			SMM			
		5014 5024 5034 5044	5624 5634 5644 5654	6324 6334 6344	5014 5024 5034	5624 5634 5644	6324 6334	
CMP	056/030	60 - 150			60 - 150			
	056/040	60 - 300				60 - 300		
	063/040			60 - 120			60 - 120	

60 - 300

Rapporti di riduzione i
Ratio i

Dati tecnici

Technical data

P_1 [kW]	n_2 [min ⁻¹]	M_2 [Nm]	sf	i			P_1 [kW]	n_2 [min ⁻¹]	M_2 [Nm]	sf	i		
0.04							0.06						
SMT5014	280	1.2	11.0	5	CM026		SMT5024	280	1.8	10.2	5	CM030	
SMM5014	187	1.7	8.1	7.5	CM026		SMM5024	187	2.6	7.7	7.5	CM030	
(1400 min ⁻¹)	140	2.3	6.2	10	CM026		(1400 min ⁻¹)	140	3.4	6.1	10	CM030	
	93	3.2	4.4	15	CM026			93	4.9	4.3	15	CM030	
	70	4.0	3.5	20	CM026			70	6.1	3.1	20	CM030	
	47	5.4	2.8	30	CM026			56	7.4	2.7	25	CM030	
	35	6.7	2.1	40	CM026			47	8.2	2.7	30	CM030	
	28	7.8	1.7	50	CM026			35	10	2.0	40	CM030	
	23	8.7	1.4	60	CM026			28	12	1.6	50	CM030	
								23	14	1.3	60	CM030	
	280	1.2	15.3	5	CM030			23	16	1.6	60		CMP056/030
	187	1.7	11.5	7.5	CM030			19	19	1.4	75		CMP056/030
	140	2.3	9.2	10	CM030			18	16	1.0	80	CM030	
	93	3.2	6.5	15	CM030			16	21	1.6	90		CMP056/030
	70	4.1	4.6	20	CM030			14	18	0.8	100	CM030	
	56	4.9	4.1	25	CM030			12	25	1.1	120		CMP056/030
	47	5.5	4.0	30	CM030			9	29	0.9	150		CMP056/030
	35	6.8	3.0	40	CM030								
	28	7.9	2.4	50	CM030			35	11	3.9	40	CM040	
	23	9.0	1.9	60	CM030			28	12	3.2	50	CM040	
	23	11	2.4	60		CMP056/030		23	14	2.5	60	CM040	
	19	12	2.1	75		CMP056/030		23	17	3.4	60		CMP056/040
	18	10	1.4	80	CM030			19	20	2.6	75		CMP056/040
	16	14	2.3	90		CMP056/030		18	17	1.9	80	CM040	
	14	12	1.2	100	CM030			16	23	3.1	90		CMP056/040
	12	17	1.7	120		CMP056/030		14	19	1.6	100	CM040	
	9	20	1.4	150		CMP056/030		12	28	2.2	120		CMP056/040
								9	32	1.8	150		CMP056/040
	23	9.5	3.8	60	CM040			8	35	1.5	180		CMP056/040
	23	11	5.2	60		CMP056/040		6	41	1.1	240		CMP056/040
	19	13	3.9	75		CMP056/040		5	46	0.9	300		CMP056/040
	18	11	2.9	80	CM040								
	16	15	4.7	90		CMP056/040							
	14	13	2.5	100	CM040								
	12	19	3.3	120		CMP056/040							
	9	21	2.7	150		CMP056/040							
	8	24	2.3	180		CMP056/040							
	6	28	1.7	240		CMP056/040							
	5	30	1.4	300		CMP056/040							
0.06							0.09						
SMT5024	280	1.8	7.3	5	CM026		SMT5034	280	2.7	4.9	5	CM026	
SMM5024	187	2.6	5.4	7.5	CM026		SMM5034	187	3.9	3.6	7.5	CM026	
(1400 min ⁻¹)	140	3.4	4.1	10	CM026		SMT5624	140	5.1	2.7	10	CM026	
	93	4.8	2.9	15	CM026		SMM5624	93	7.2	1.9	15	CM026	
	70	6.1	2.3	20	CM026		(1400 min ⁻¹)	70	9.1	1.5	20	CM026	
	47	8.1	1.9	30	CM026			47	12	1.2	30	CM026	
	35	10	1.4	40	CM026			35	15	0.9	40	CM026	
	28	12	1.1	50	CM026			28	17	0.7	50	CM026	
	23	13	0.9	60	CM026								

AC



Motori Motors	SMT		SMM	
	5014 5024 5034	5624	5014 5024 5034	5624
IEC	56 B14		56 B14	

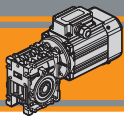







CM
CMP

Motoriduttori CA a vite senza fine
AC Wormgearmotors



Dati tecnici

Technical data

P ₁ [kW]	n ₂ [min ⁻¹]	M ₂ [Nm]	sf	i			P ₁ [kW]	n ₂ [min ⁻¹]	M ₂ [Nm]	sf	i		
0.09							0.12						
SMT5034	280	2.6	6.8	5	CM030		SMT5044	93	10	4.5	15	CM040	
SMM5034	187	3.9	5.1	7.5	CM030		SMT5634	70	13	3.1	20	CM040	
SMT5624	140	5.2	4.1	10	CM030		SMM5634	56	15	2.5	25	CM040	
SMM5624	93	7.3	2.9	15	CM030		(1400 min ⁻¹)	47	17	2.8	30	CM040	
(1400 min ⁻¹)	70	9.2	2.1	20	CM030			35	21	2.0	40	CM040	
	56	11	1.8	25	CM030		28	25	1.6	50	CM040		
	47	12	1.8	30	CM030		23	28	1.3	60	CM040		
	35	15	1.3	40	CM030		23	34	1.7	60	CM040		
	28	18	1.1	50	CM030		19	40	1.3	75	CM040	CMP056/040	
	23	20	0.8	60	CM030		18	34	1.0	80	CM040	CMP056/040	
	23	24	1.1	60		CMP056/030	16	45	1.6	90		CMP056/040	
	19	29	0.9	75		CMP056/030	14	38	0.8	100	CM040	CMP056/040	
	16	32	1.0	90		CMP056/030	12	56	1.1	120		CMP056/040	
							9	64	1.0	150		CMP056/040	
	70	10	4.2	20	CM040		0.18						
	56	11	3.3	25	CM040		SMT5644	280	5.3	2.4	5	CM026	
	47	13	3.7	30	CM040		SMM5644	187	7.7	1.8	7.5	CM026	
	35	16	2.6	40	CM040		(1400 min ⁻¹)	140	10	1.4	10	CM026	
	28	18	2.1	50	CM040			93	14	1.0	15	CM026	
	23	21	1.7	60	CM040		70	18	0.8	20	CM026		
	23	25	2.3	60		CMP056/040		280	5.3	3.4	5	CM030	
	19	30	1.7	75		CMP056/040		187	7.8	2.6	7.5	CM030	
	18	26	1.3	80	CM040		140	10	2.0	10	CM030		
	16	34	2.1	90		CMP056/040		93	15	1.4	15	CM030	
	14	28	1.1	100	CM040		70	18	1.0	20	CM030		
	12	42	1.5	120		CMP056/040		56	22	0.9	25	CM030	
	9	48	1.2	150		CMP056/040		47	25	0.9	30	CM030	
	8	53	1.0	180		CMP056/040							
0.12								280	5.4	7.6	5	CM040	
SMT5044	280	3.6	3.7	5	CM026		187	7.9	5.6	7.5	CM040		
SMT5634	187	5.2	2.7	7.5	CM026		140	10	4.4	10	CM040		
SMM5634	140	6.8	2.1	10	CM026		93	15	3.0	15	CM040		
(1400 min ⁻¹)	93	10	1.5	15	CM026		70	19	2.1	20	CM040		
	70	12	1.2	20	CM026		56	23	1.7	25	CM040		
	47	16	0.9	30	CM026		47	26	1.9	30	CM040		
	35	20	0.7	40	CM026		35	32	1.3	40	CM040		
	280	3.5	5.1	5	CM030		28	37	1.1	50	CM040		
	187	5.2	3.8	7.5	CM030		23	43	0.8	60	CM040		
	140	6.9	3.1	10	CM030		23	51	1.1	60		CMP056/040	
	93	10	2.2	15	CM030		19	60	0.9	75		CMP056/040	
	70	12	1.5	20	CM030		18	68	1.0	90		CMP056/040	
	56	15	1.4	25	CM030								
	47	16	1.3	30	CM030		280	5.3	3.4	5	CM030		
	35	20	1.0	40	CM030		187	7.8	2.6	7.5	CM030		
	28	24	0.8	50	CM030		140	10	2.0	10	CM030		
	23	32	0.8	60		CMP056/030	93	15	1.4	15	CM030		
							70	18	1.0	20	CM030		
							56	22	0.9	25	CM030		
							47	25	0.9	30	CM030		



Motori Motors	SMT		SMM	
	5034 5044	5624 5634 5644	5034	5624 5634 5644
IEC	56 B14		56 B14	

Dati tecnici

Technical data

P ₁ [kW]	n ₂ [min ⁻¹]	M ₂ [Nm]	sf	i		
0.18						
SMT6324	280	5.4	7.6	5	CM040	CMP063/040 CMP063/040 CMP063/040
SMM6324	187	7.9	5.6	7.5	CM040	
(1400 min ⁻¹)	140	10	4.4	10	CM040	
	93	15	3.0	15	CM040	
	70	19	2.1	20	CM040	
	56	23	1.7	25	CM040	
	47	26	1.9	30	CM040	
	35	32	1.3	40	CM040	
	28	37	1.1	50	CM040	
	23	43	0.8	60	CM040	
	23	51	1.1	60		
	19	60	0.9	75		
	18	68	1.0	90		

P ₁ [kW]	n ₂ [min ⁻¹]	M ₂ [Nm]	sf	i		
0.25						
SMT6334	280	7.5	5.5	5	CM040	CMP063/040
SMM6334	187	11	4.0	7.5	CM040	
(1400 min ⁻¹)	140	14	3.1	10	CM040	
	93	21	2.2	15	CM040	
	70	27	1.5	20	CM040	
	56	32	1.2	25	CM040	
	47	36	1.3	30	CM040	
	35	44	0.9	40	CM040	
	28	51	0.8	50	CM040	
	23	70	0.8	60		

P ₁ [kW]	n ₂ [min ⁻¹]	M ₂ [Nm]	sf	i		
0.25						
SMT5654	280	7	1.8	5	CM026	CMP056/040
(1400 min ⁻¹)	187	11	1.3	8	CM026	
	140	14	1.0	10	CM026	
	280	7.3	2.5	5	CM030	
	187	11	1.8	7.5	CM030	
	140	14	1.5	10	CM030	
	93	20	1.0	15	CM030	
	70	26	0.7	20	CM030	
	280	7.5	5.5	5	CM040	
	187	11	4.0	7.5	CM040	
	140	14	3.1	10	CM040	
	93	21	2.2	15	CM040	
	70	27	1.5	20	CM040	
	56	32	1.2	25	CM040	
	47	36	1.3	30	CM040	
	35	44	0.9	40	CM040	
	28	51	0.8	50	CM040	
	23	70	0.8	60		

P ₁ [kW]	n ₂ [min ⁻¹]	M ₂ [Nm]	sf	i		
0.37						
SMT6344	280	11	1.7	5	CM030	CMP063/040
(1400 min ⁻¹)	187	16	1.2	7.5	CM030	
	140	21	1.0	10	CM030	
	93	30	0.7	15	CM030	
	280	11	3.7	5	CM040	
	187	16	2.7	7.5	CM040	
	140	21	2.1	10	CM040	
	93	31	1.5	15	CM040	
	70	39	1.0	20	CM040	
	56	47	0.8	25	CM040	
	47	53	0.9	30	CM040	

P ₁ [kW]	n ₂ [min ⁻¹]	M ₂ [Nm]	sf	i		
0.25						
SMT6334	280	7.3	2.5	5	CM030	CMP063/040
SMM6334	187	11	1.8	7.5	CM030	
(1400 min ⁻¹)	140	14	1.5	10	CM030	
	93	20	1.0	15	CM030	
	70	26	0.7	20	CM030	

P ₁ [kW]	n ₂ [min ⁻¹]	M ₂ [Nm]	sf	i		
0.37						
SMT7124	280	11	3.7	5	CM040	CMP063/040
SMM7124	187	16	2.7	7.5	CM040	
(1400 min ⁻¹)	140	21	2.1	10	CM040	
	93	31	1.5	15	CM040	
	70	39	1.0	20	CM040	
	56	47	0.8	25	CM040	
	47	53	0.9	30	CM040	

P ₁ [kW]	n ₂ [min ⁻¹]	M ₂ [Nm]	sf	i		
0.55						
SMT7134	280	17	2.5	5	CM040	CMP063/040
SMM7134	187	24	1.8	7.5	CM040	
(1400 min ⁻¹)	140	32	1.4	10	CM040	
	93	46	1.0	15	CM040	

P ₁ [kW]	n ₂ [min ⁻¹]	M ₂ [Nm]	sf	i		
0.75						
SMT7144	280	23	1.8	5	CM040	CMP063/040
(1400 min ⁻¹)	187	33	1.3	7.5	CM040	
	140	43	1.0	10	CM040	



Motori Motors	SMT			SMM	
	5654	6324 6334 6344	7124 7134 7144	6324 6334	7124 7134
IEC	56 B14	63 B14	71 B14	63 B14	71 B14

Dati tecnici elettrici

Electrical technical data



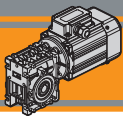

CM
CMP

Dimensioni

Dimensions

CM 026 .. U

SMT50...TEFC
SMM50... TEFC

SMT50...TENV
SMM50... TENV

S3 servizio 30%
duty

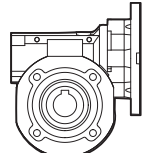
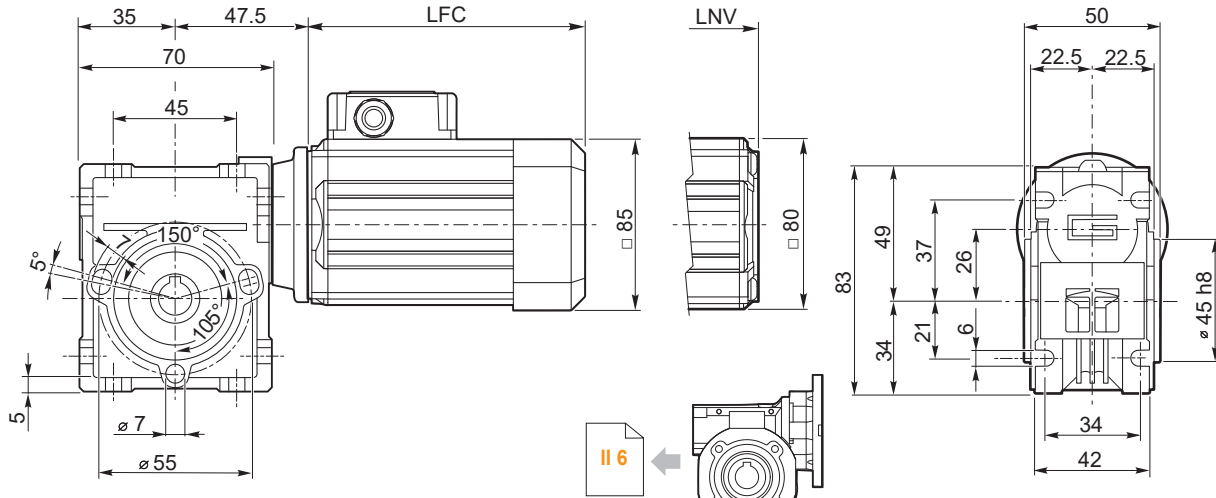

Albero lento cavo / Hollow output shaft

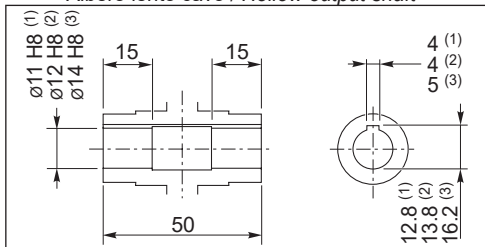

SMT	LFC	LNV	Kg	
5014	135.5	108.5	3.1	
5024	150.5	123.5	3.5	
5034	175.5	148.5	4.3	
5044	200.5	173.5	5	

SMM	LFC	LNV	Kg	
5014	150.5	123.5	3.5	
5024	175.5	148.5	4.3	
5034	200.5	173.5	5	

Nota: il condensatore sarà fornito a corredo
Note: the capacitor will be supplied separately

- (1): CM 120/026 (D11)
- (2): CM 120/026
- (3): CM 120/026 (D14)

CM 026 .. U

SMT56...TEFC
SMM56... TEFC

SMT56...TENV
SMM56... TENV

S3 servizio 30%
duty

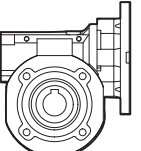
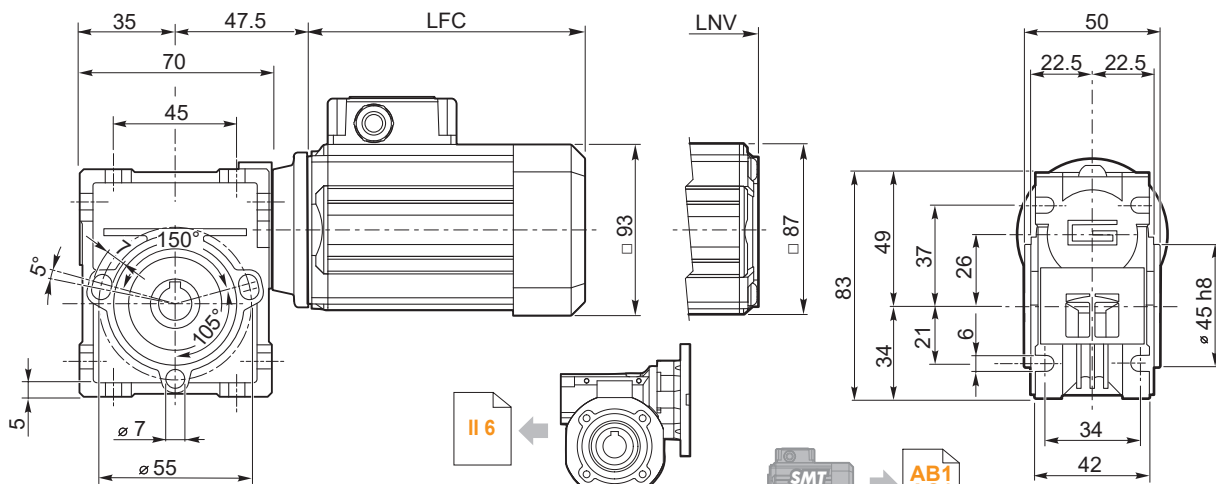

Albero lento cavo / Hollow output shaft

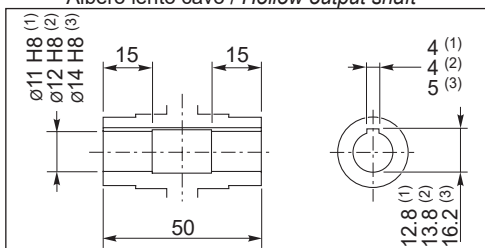

SMT	LFC	LNV	Kg	
5624	141	117	3.6	
5634	151	127	4	
5644	186	162	5.2	
5654	206	182	5.9	

SMM	LFC	LNV	Kg	
5624	151	127	3.9	
5634	171	147	4.5	
5644	206	182	5.8	

Nota: il condensatore sarà fornito a corredo
Note: the capacitor will be supplied separately

- (1): CM 120/026 (D11)
- (2): CM 120/026
- (3): CM 120/026 (D14)

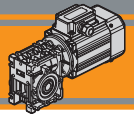

Dimensioni

Dimensions

CM 026 .. F

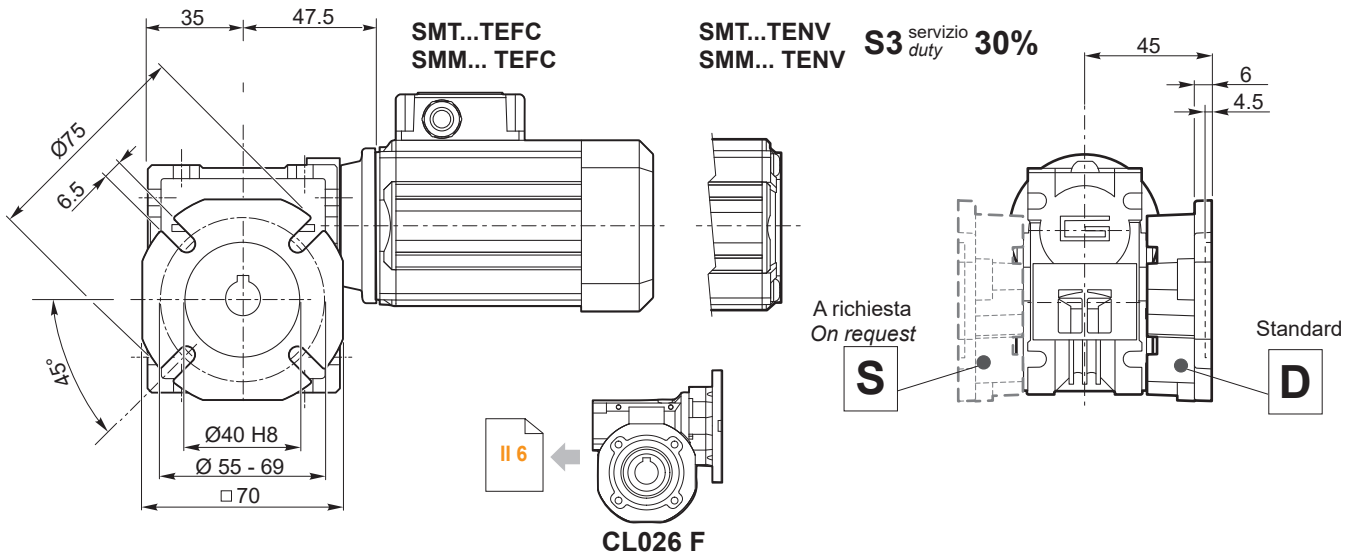

CM 026 .. F28

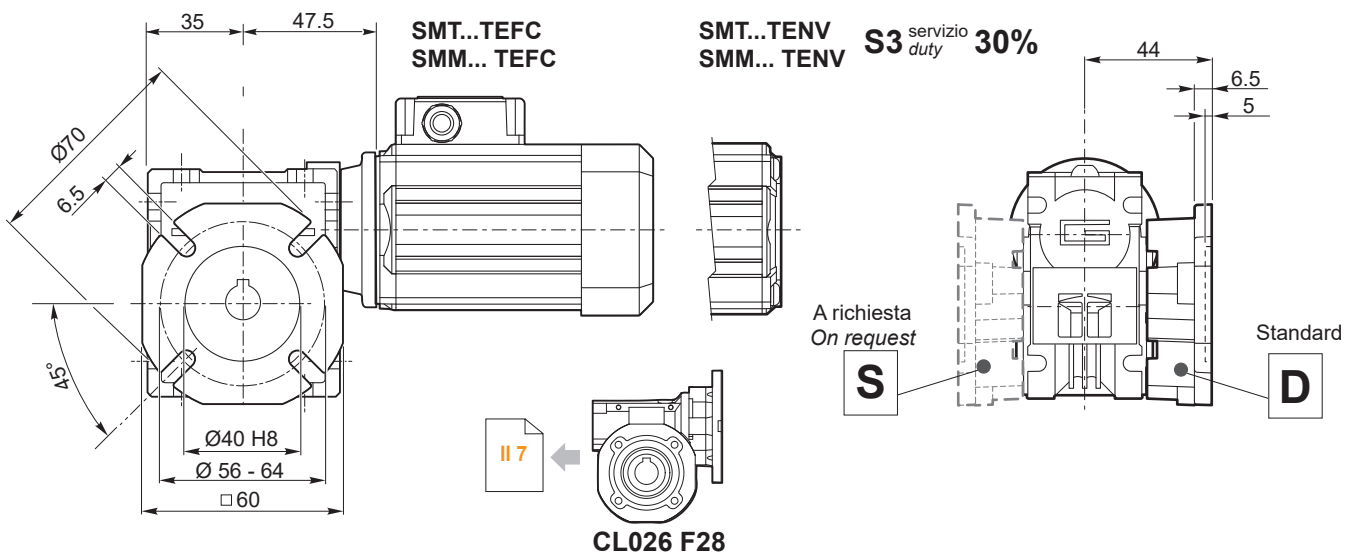

CM 026 .. F30

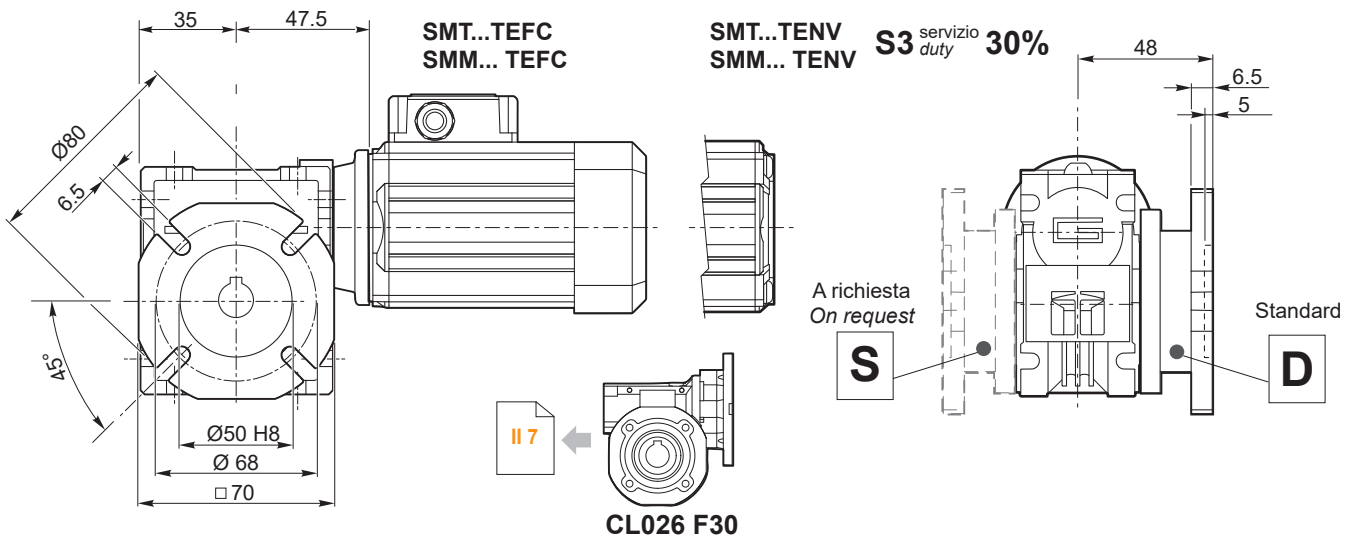

AC

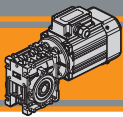

CM
CMP

Motoriduttori CA a vite senza fine
AC Wormgearmotors

MINI
TECNO

Dimensioni

Dimensions

CM 026 .. F30C

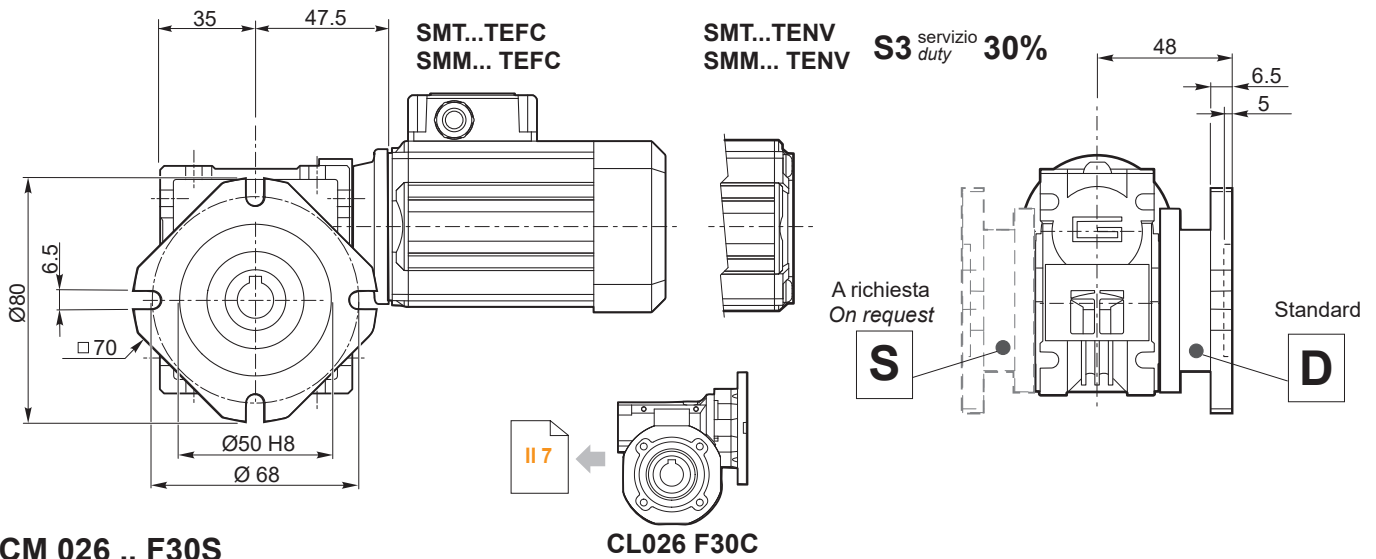

CM 026 .. F30S

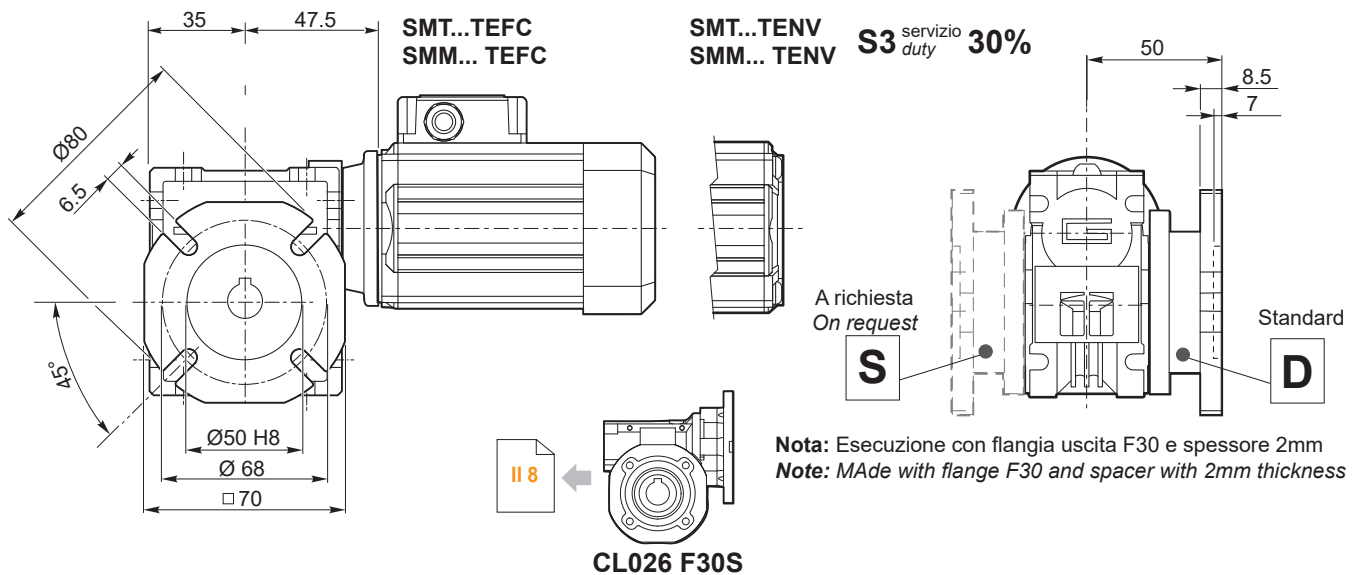

CM 026 .. F30SC

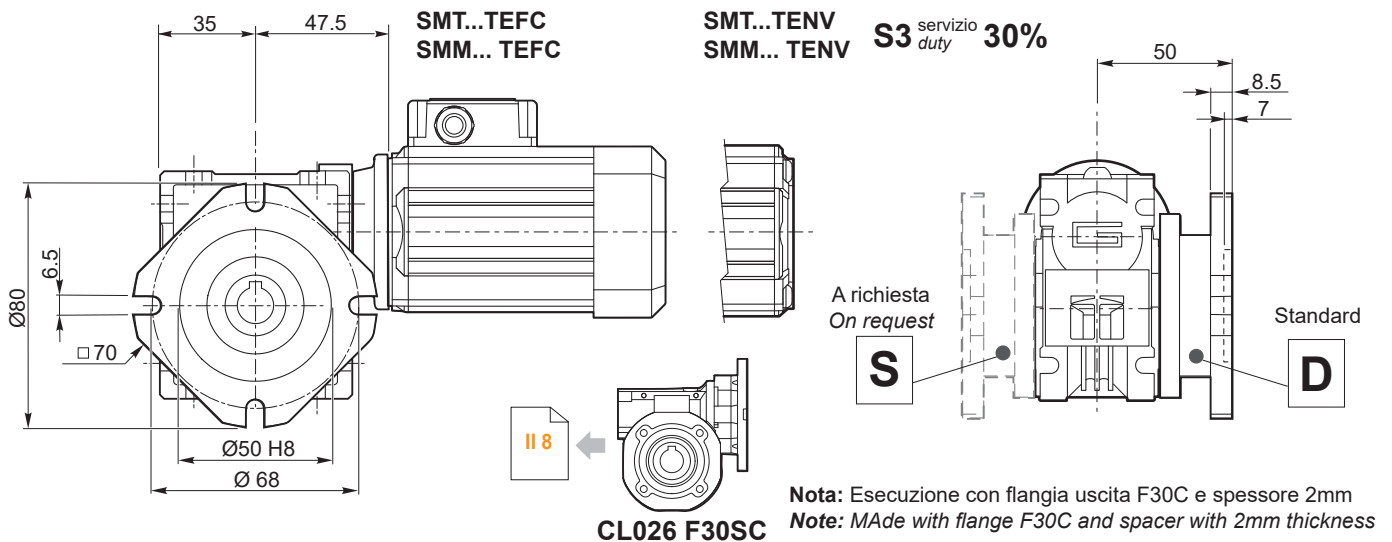

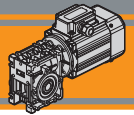

Dimensioni

Dimensions

CM 026 .. F100

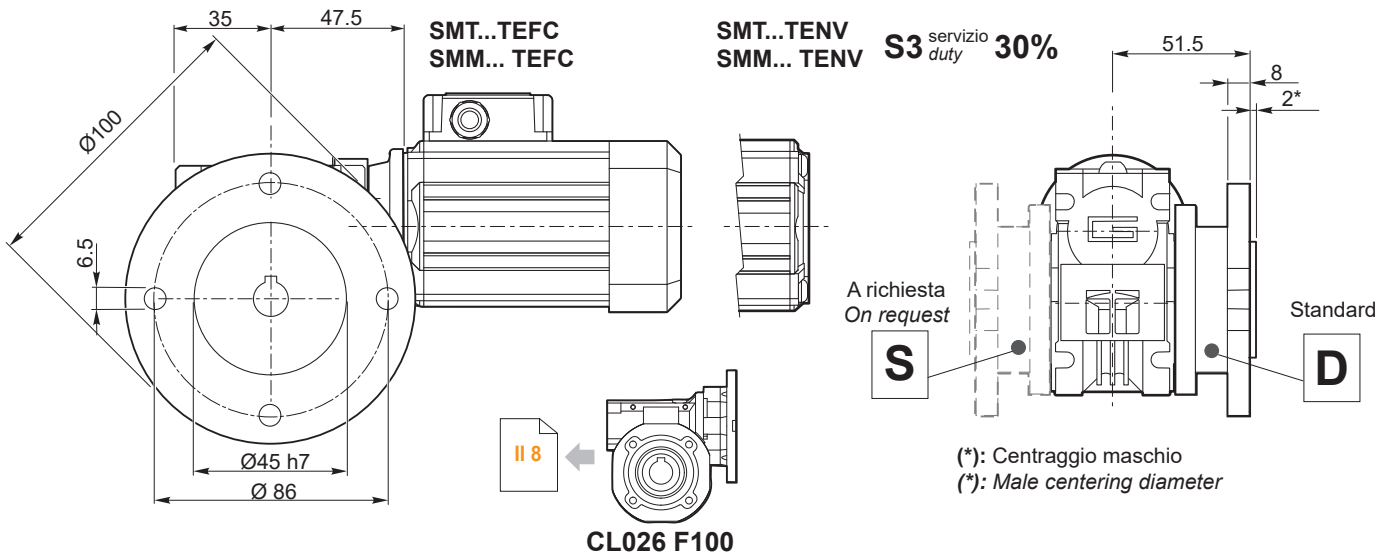

CM 030 ...U

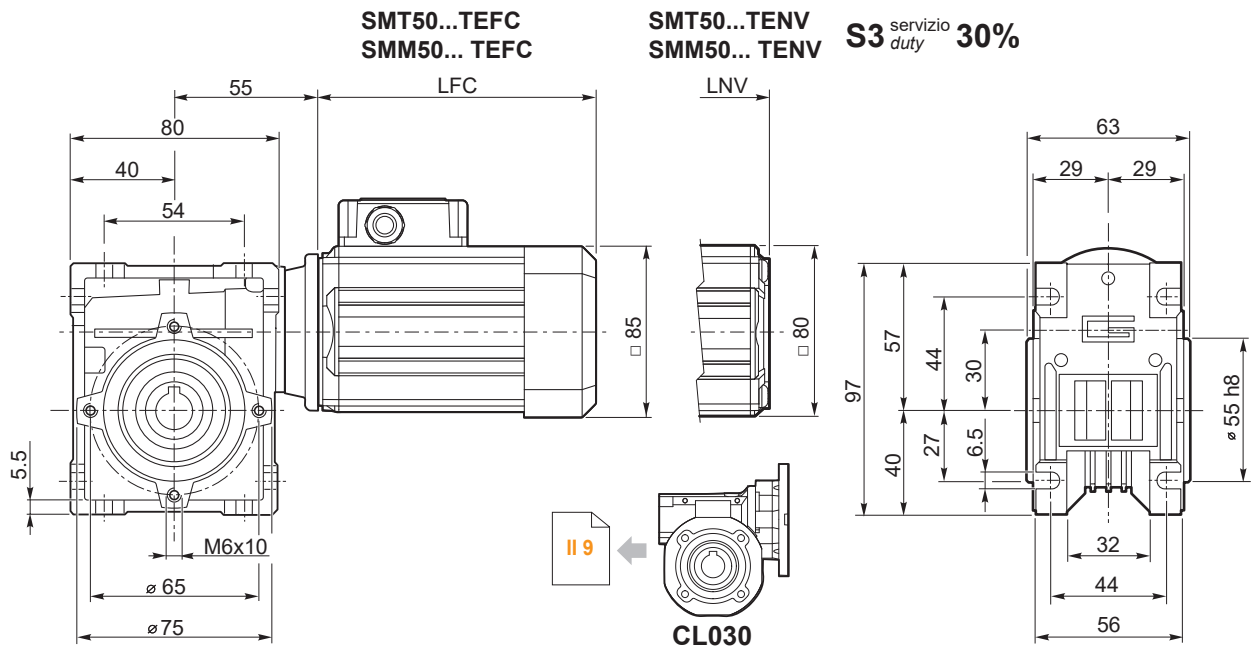

Albero lento cavo / Hollow output shaft

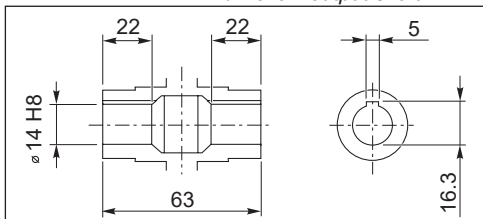

SMT	LFC	LNV	Kg	
5014	135.5	108.5	3.5	
5024	150.5	123.5	3.9	
5034	175.5	148.5	4.7	
5044	200.5	173.5	5.4	

SMM	LFC	LNV	Kg	
5014	150.5	123.5	3.9	
5024	175.5	148.5	4.7	
5034	200.5	173.5	5.4	

Nota: il condensatore sarà fornito a corredo
Note: the capacitor will be supplied separately

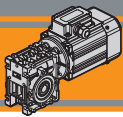

CM
CMP

Motoriduttori CA a vite senza fine AC Wormgearmotors



Dimensioni

Dimensions

CM 030 ...U

SMT56...TEFC
SMM56... TEFC

SMT56...TENV
SMM56... TENV

S3 servizio 30%
duty

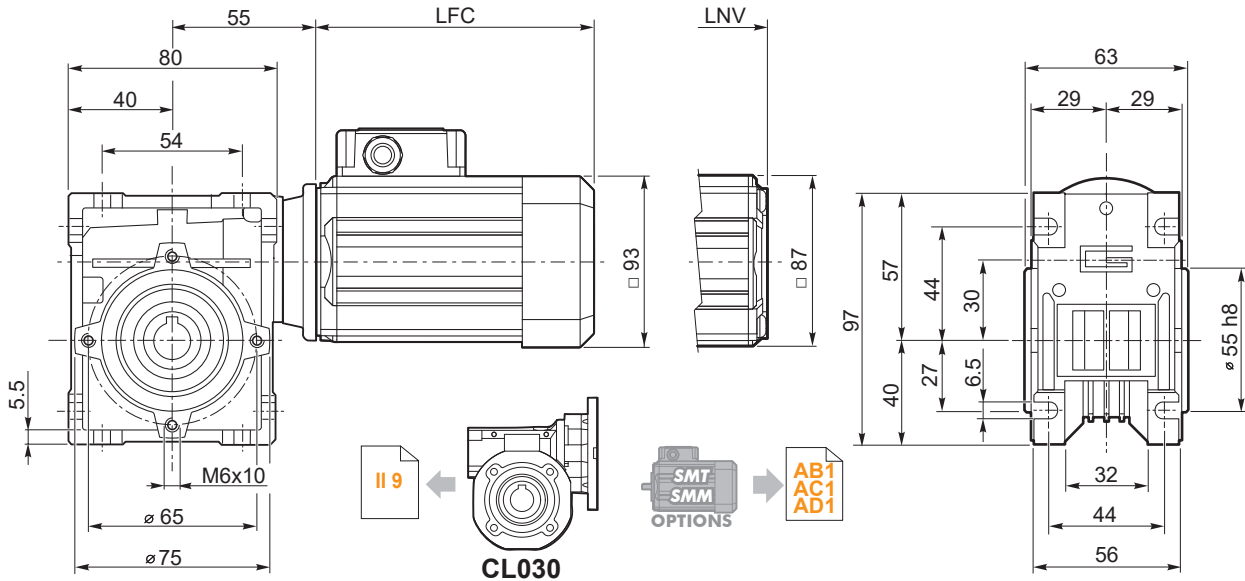

Albero lento cavo / Hollow output shaft

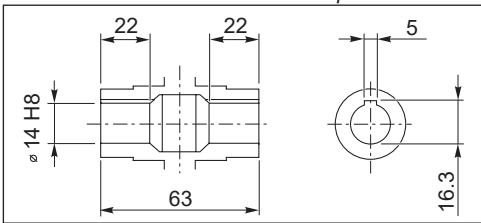

SMT	LFC	LNV	Kg	
5624	141	117	4	
5634	151	127	4.4	
5644	186	162	5.6	
5654	206	182	6.3	

SMM	LFC	LNV	Kg	
5624	151	127	4.3	
5634	171	147	4.9	
5644	206	182	6.2	

Nota: il condensatore sarà fornito a corredo
Note: the capacitor will be supplied separately

CM 030 ...U

SMT63...TEFC
SMM63... TEFC

SMT63...TENV
SMM63... TENV

S3 servizio 30%
duty

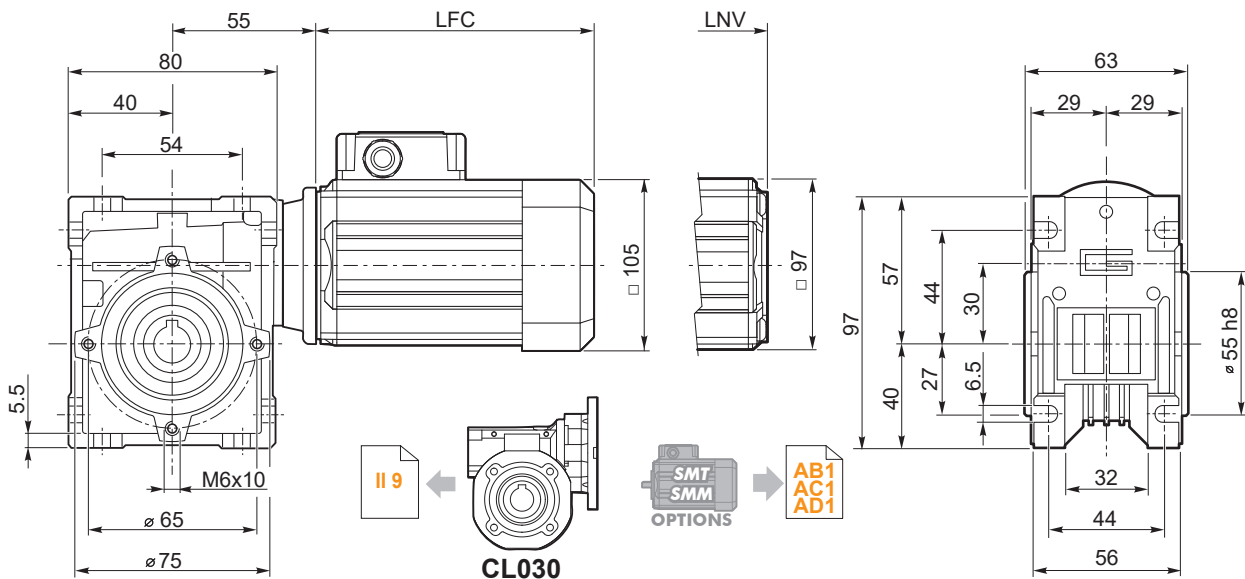

Albero lento cavo / Hollow output shaft

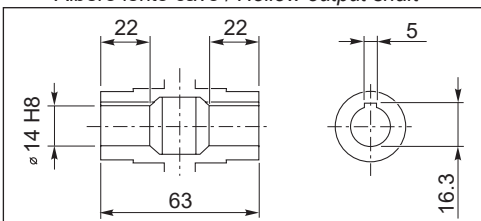

SMT	LFC	LNV	Kg	
6324	165.5	138.5	5.5	
6334	180.5	153.5	6.2	
6344	205.5	178.5	7.4	

SMM	LFC	LNV	Kg	
6324	180.5	153.5	6.3	
6334	205.5	178.5	7.5	

Nota: il condensatore sarà fornito a corredo
Note: the capacitor will be supplied separately

Dimensioni

Dimensions

CMP 056/030 ...U

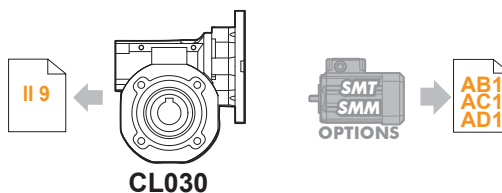
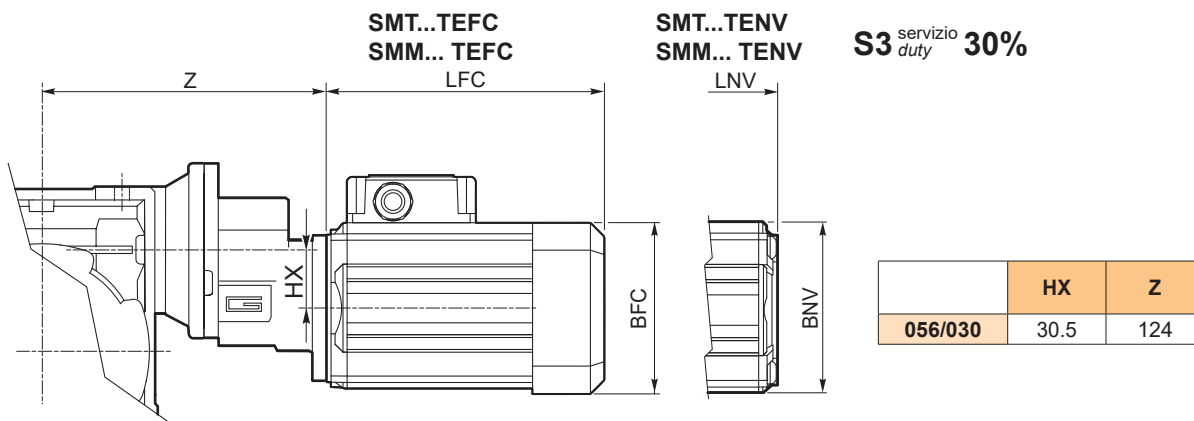

SMT	BFC	BNV	LFC	LNV
5014	□ 85	□ 80	135.5	108.5
5024			150.5	123.5
5034			175.5	148.5
5044			200.5	173.5
5624	□ 93	□ 87	141	117
5634			151	127
5644			186	162
5654			206	182

SMM	BFC	BNV	LFC	LNV
5014	□ 85	□ 80	150.5	123.5
5024			175.5	148.5
5034			200.5	173.5
5624			□ 93	□ 87
5634	186	162		
5644	206	182		

Nota: il condensatore sarà fornito a corredo
Note: the capacitor will be supplied separately

CM 030 ... - F

CMP 056/030 ... - F

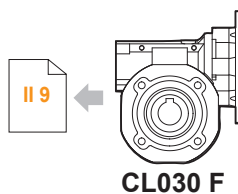
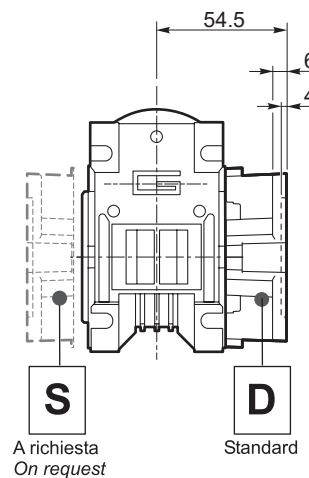
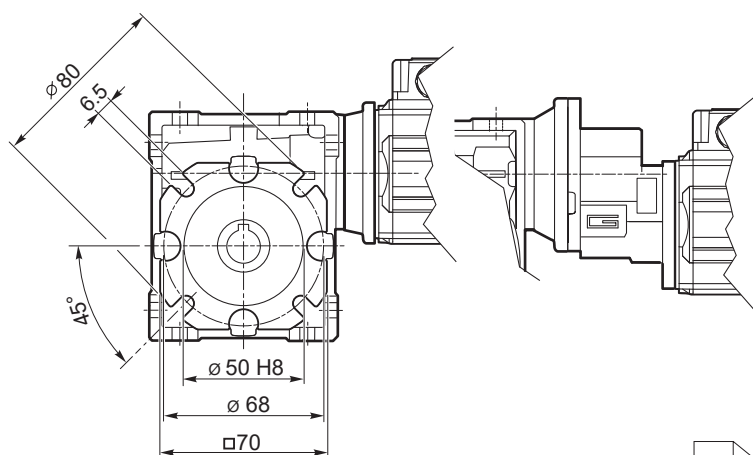

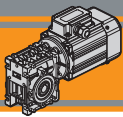

CM
CMP

Motoriduttori CA a vite senza fine
AC Wormgearmotors



Dimensioni

Dimensions

CM 040 ...U

SMT50...TEFC
SMM50... TEFC

SMT50...TENV
SMM50... TENV

S3 servizio 30%
duty

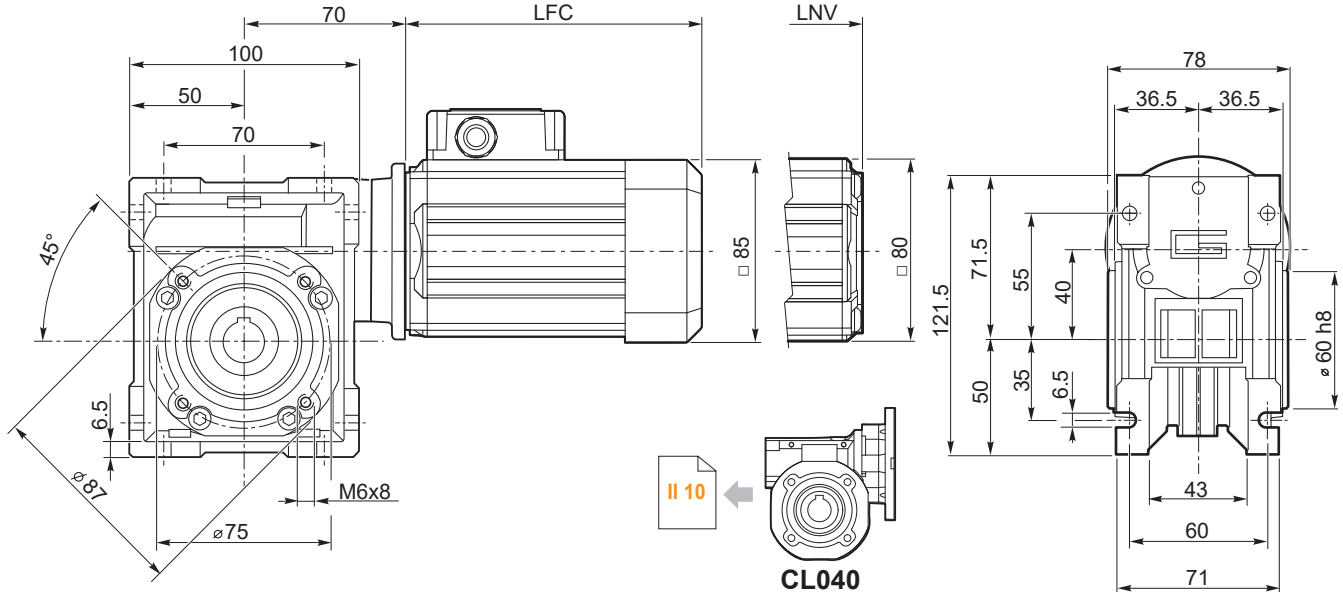

Albero lento cavo / Hollow output shaft

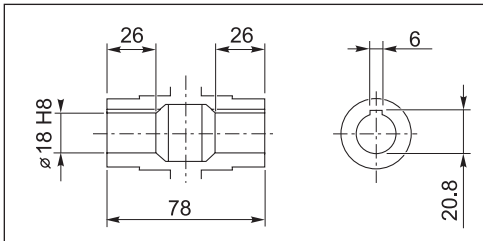

SMT	LFC	LNV	Kg	
5014	135.5	108.5	4.6	
5024	150.5	123.5	5	
5034	175.5	148.5	5.8	
5044	200.5	173.5	6.5	

SMM	LFC	LNV	Kg	
5014	150.5	123.5	5	
5024	175.5	148.5	5.8	
5034	200.5	173.5	6.5	

Nota: il condensatore sarà fornito a corredo
Note: the capacitor will be supplied separately

CM 040 ...U

SMT56...TEFC
SMM56... TEFC

SMT56...TENV
SMM56... TENV

S3 servizio 30%
duty

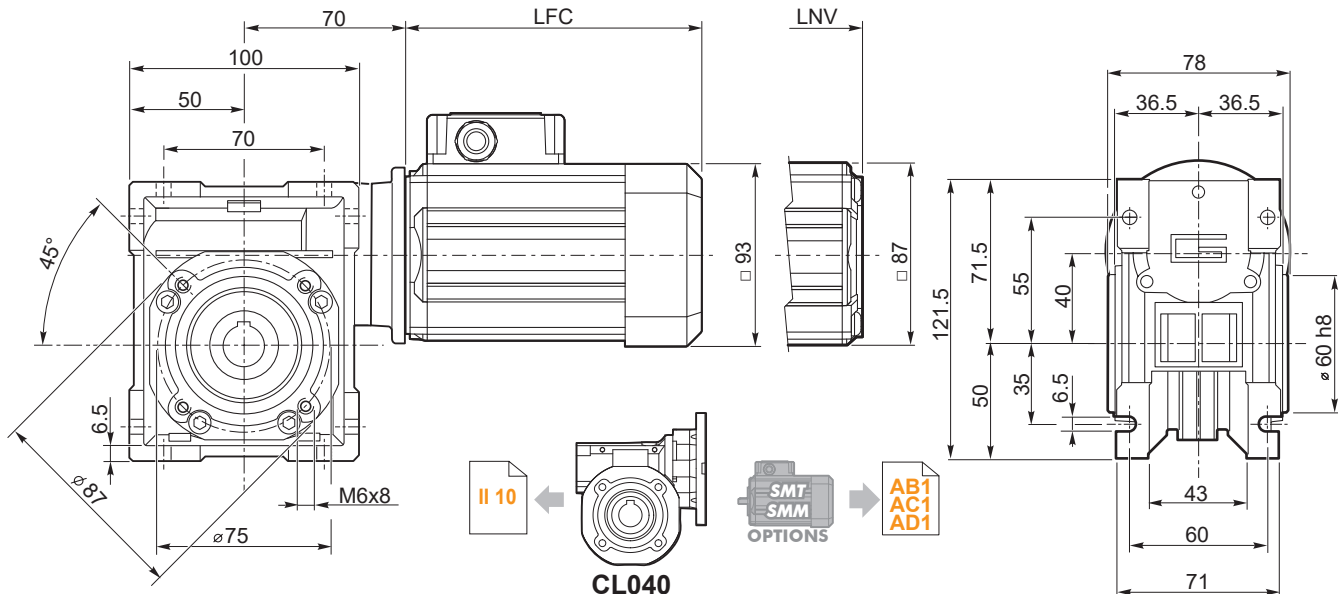

Albero lento cavo / Hollow output shaft

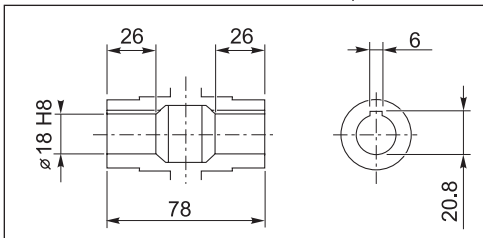

SMT	LFC	LNV	Kg	
5624	141	117	5.1	
5634	151	127	5.5	
5644	186	162	6.7	
5654	206	182	7.4	

SMM	LFC	LNV	Kg	
5624	151	127	5.4	
5634	171	147	6	
5644	206	182	7.3	

Nota: il condensatore sarà fornito a corredo
Note: the capacitor will be supplied separately

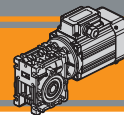

Dimensioni

Dimensions

CM 040 ...U

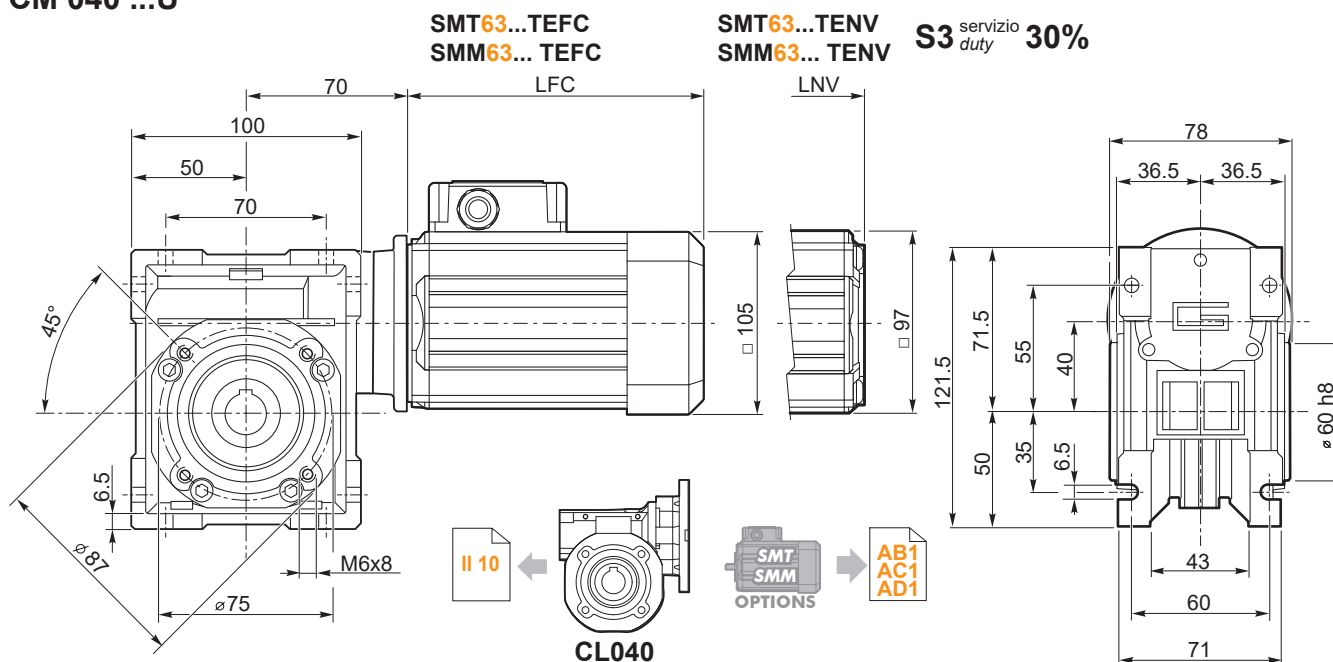

Albero lento cavo / Hollow output shaft

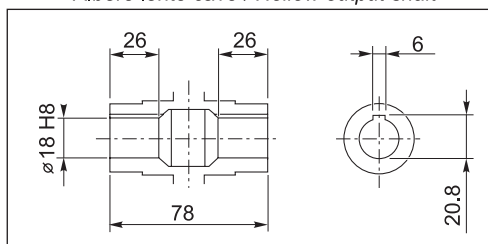

SMT	LFC	LNV	Kg	
6324	165.5	138.5	6.6	
6334	180.5	153.5	7.3	
6344	205.5	178.5	8.5	

SMM	LFC	LNV	Kg	
6324	180.5	153.5	7.4	
6334	205.5	178.5	8.6	

Nota: il condensatore sarà fornito a corredo
Note: the capacitor will be supplied separately

CM 040 ...U

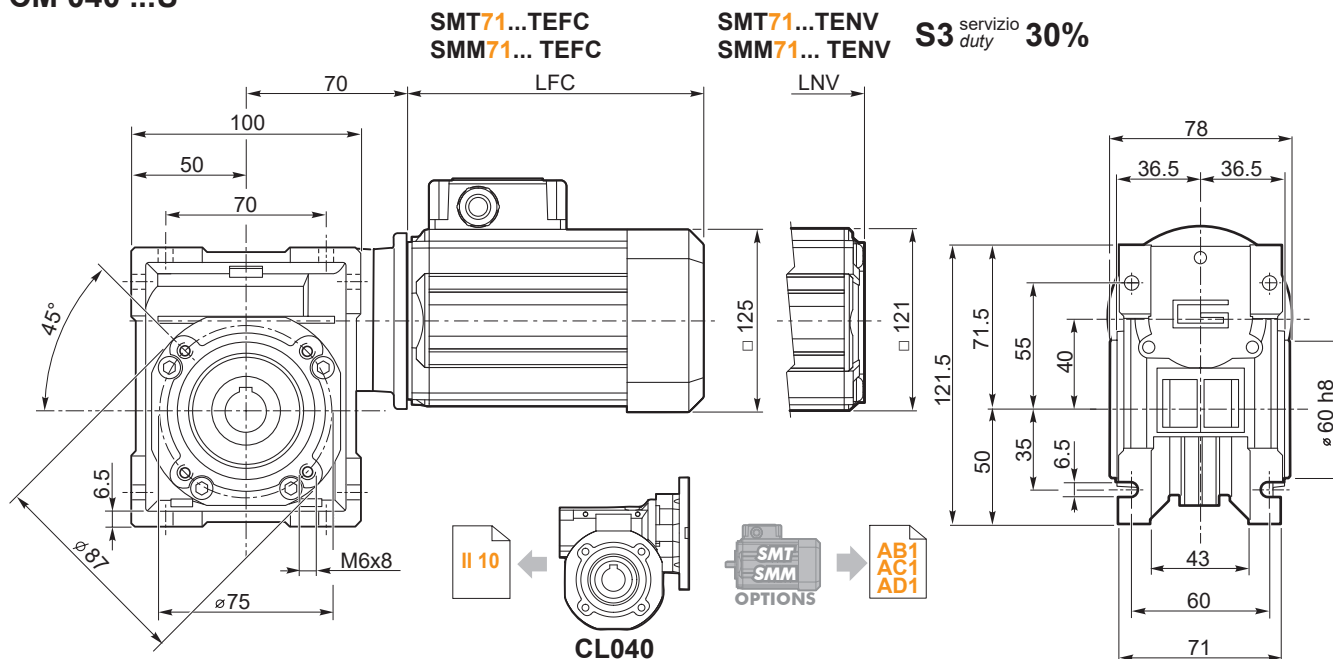

Albero lento cavo / Hollow output shaft

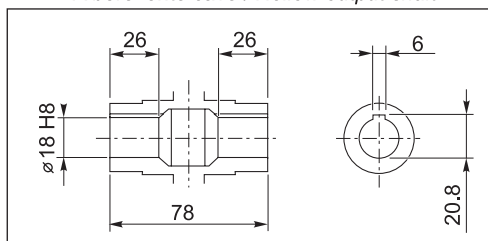

SMT	LFC	LNV	Kg	
7124	174	145.5	8.8	
7134	189	160.5	9.9	
7144	214	185.5	11.6	

SMM	LFC	LNV	Kg	
7124	189	160.5	9.5	
7134	214	185.5	11.5	

Nota: il condensatore sarà fornito a corredo
Note: the capacitor will be supplied separately

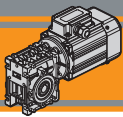

CM
CMP

Dimensioni

Dimensions

CMP .../040 ...U

SMT...TEFC
SMM... TEFC

SMT...TENV
SMM... TENV

S3 servizio duty 30%

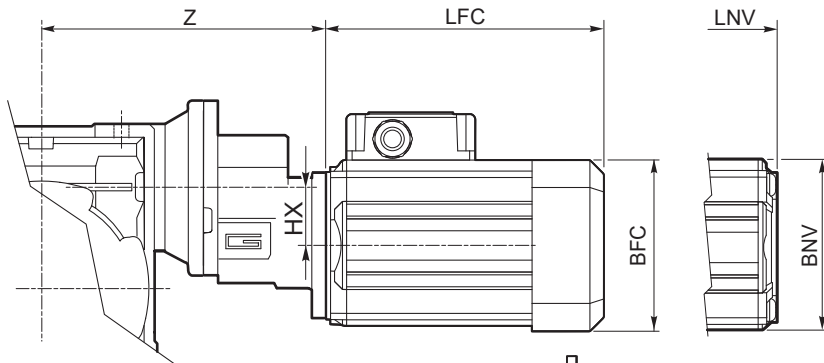

	HX	Z
056/040	30.5	139
063/040	30.5	142

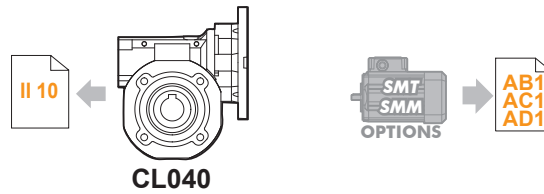

CL040

SMT	BFC	BNV	LFC	LNV
5014	□ 85	□ 80	135.5	108.5
5024			150.5	123.5
5034			175.5	148.5
5044			200.5	173.5
5624	□ 93	□ 87	141	117
5634			151	127
5644			186	162
5654			206	182
6324	□ 105	□ 97	165.5	138.5
6334			180.5	153.5
6344			205.5	178.5

SMM	BFC	BNV	LFC	LNV
5014	□ 85	□ 80	150.5	123.5
5024			175.5	148.5
5034			200.5	173.5
5624			□ 93	□ 87
5634	186	162		
5644	206	182		
6324	□ 105	□ 97	180.5	153.5
6334			205.5	178.5

Nota: il condensatore sarà fornito a corredo
Note: the capacitor will be supplied separately

Dimensioni

Dimensions

CM 040 ... - F

CMP .../040 ... - F

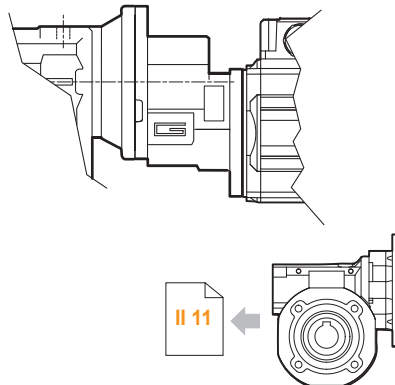
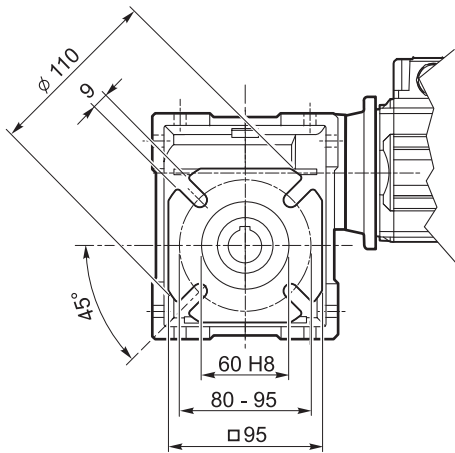

CL040 F

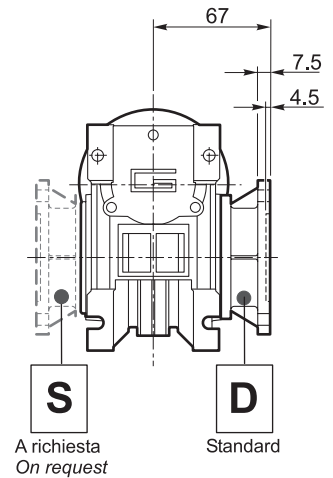

CM 040 ... - FB

CMP .../040 ... - FB

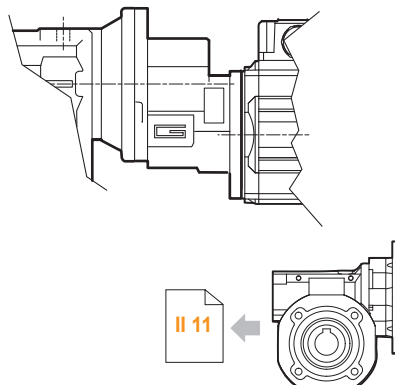
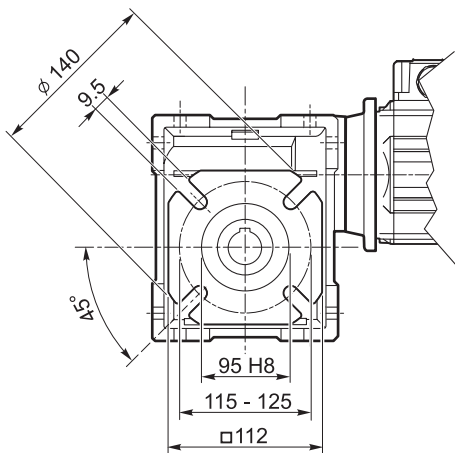

CL040 FB

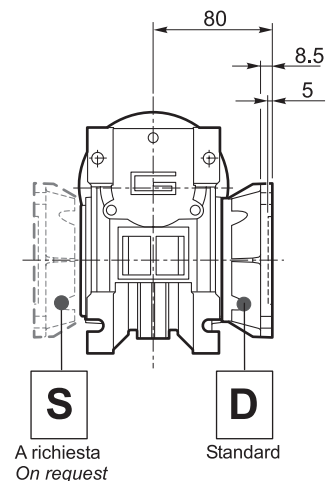

CM 040 ... - FL

CMP .../040 ... - FL

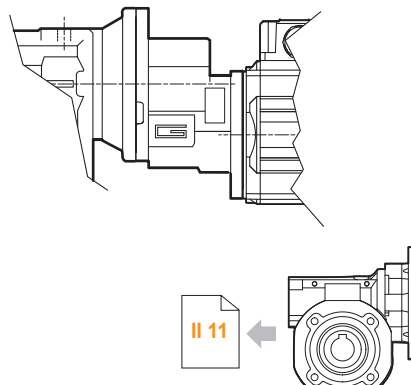
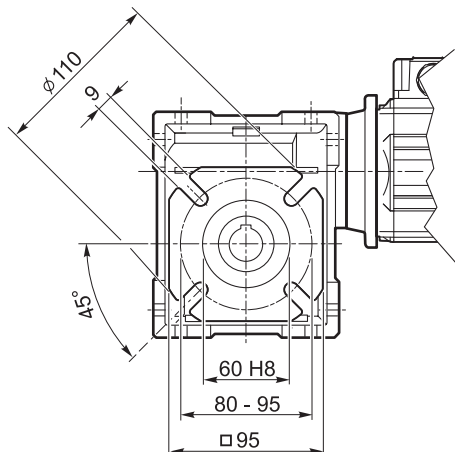

CL040 FL

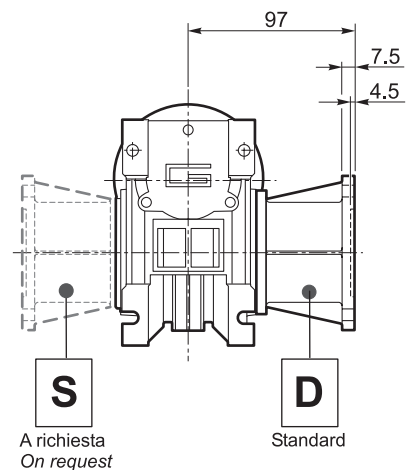

AC

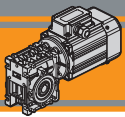

CM
CMP

Opzioni

Options

VS - Vite sporgente / *Extended input shaft*

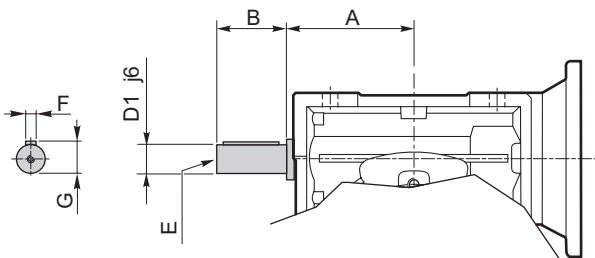

CM	CMP	A	B	D ₁ j6	E	F	G
030	056/030	45	20	9	M4	3	10.2
040	056/040 063/040	53	23	11	M5	4	12.5

 Costruito su richiesta
Built on request

Accessori

Accessories

SC - Safety cover

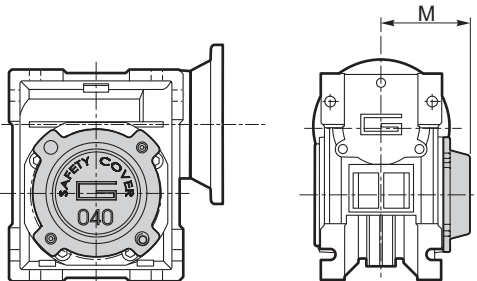

CM	CMP	M
030	056/030	47
040	056/040 063/040	54.5

WD - Kit washdown cover

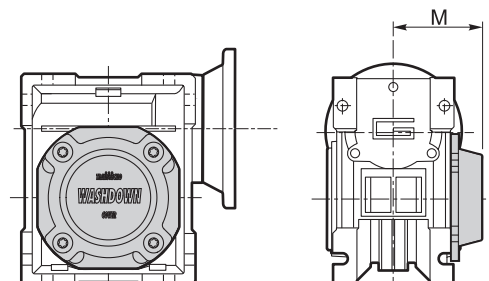

CM	CMP	M
030	056/030	48
040	056/040 063/040	55.5

Accessori

Accessories

Albero lento

Output shaft

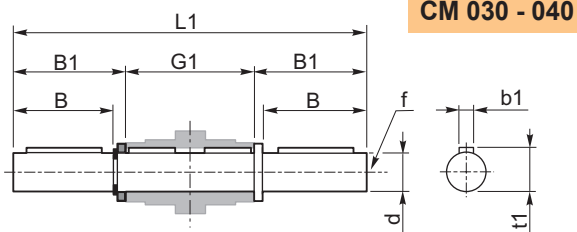

CM 030 - 040

SZ

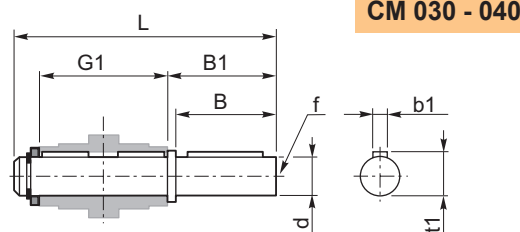

CM 030 - 040

CM	CMP	d _{h7}	B	B1	G1	L	L1	f	b1	t1
030	056/030	14	30	32.5	63	102	128	M6	5	16
040	056/040 063/040	18	40	43	78	128	164	M6	6	20.5

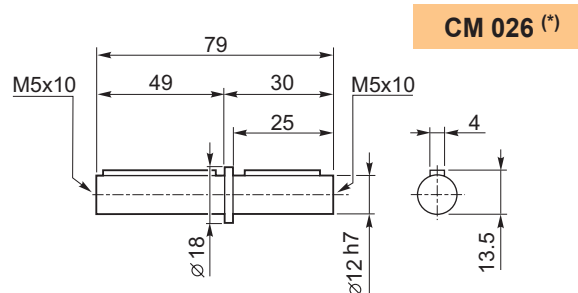

CM 026 (*)

(*)
Nota: disponibile solo per cavo uscita Ø12
Note: available for output hollow shaft Ø12 only

Braccio di reazione

Torque arm

CM	CMP	K1	G	KG	KH	R
030	056/030	85	14	23	8	15
040	056/040 063/040	100	14	31	10	18

DZ

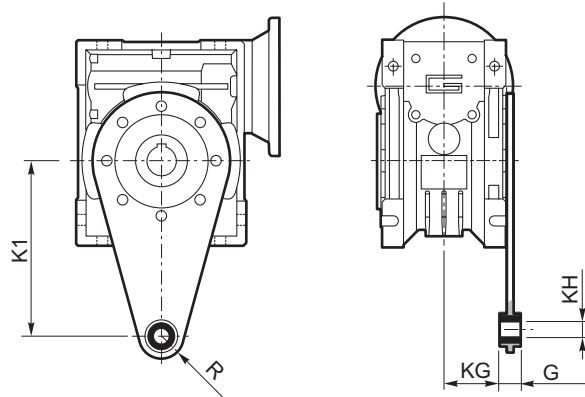

MINI  **TECNO**™
small but strong

CMM

Motoriduttori CA combinati a vite senza fine
AC Double reduction wormgearmotors



MINI  **TECNO**™ brand of
TRANSTECNO®



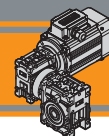

Indice	Index	Pag. Page
Caratteristiche tecniche	<i>Technical features</i>	A12
Designazione	<i>Classification</i>	A13
Simbologia	<i>Symbols</i>	A14
Esecuzioni di montaggio	<i>Mounting executions</i>	A14
Combinazioni rapporti	<i>Combination ratio</i>	A14
Lubrificazione	<i>Lubrication</i>	A14
Dati tecnici	<i>Technical data</i>	A15
Motori applicabili	<i>Motor adapters</i>	A17
Dimensioni	<i>Dimensions</i>	A18
Opzioni	<i>Options</i>	AI12
Accessori	<i>Accessories</i>	AI12

Questa sezione annulla e sostituisce ogni precedente edizione o revisione. Qualora questa sezione non Vi sia giunta in distribuzione controllata, l'aggiornamento dei dati ivi contenuto non è assicurato. **In tal caso la versione più aggiornata è disponibile sul nostro sito internet www.transtecno.com**

This section replaces any previous edition and revision. If you obtained this catalogue other than through controlled distribution channels, the most up to date content is not guaranteed. In this case the latest version is available on our web site www.transtecno.com

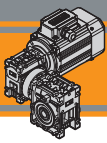
**Caratteristiche tecniche****Technical features**

Le caratteristiche principali dei motoriduttori CMM sono:

- Costruzione compatta
- Motorizzazioni in corrente alternata monofase e trifase
- Carcassa motore estrusa in alluminio anodizzato nero
- Carcasse dei riduttori in pressofusione di alluminio
- Motore elettrico AC con grado di protezione IP66
- Lubrificazione permanente con olio sintetico
- Disponibili sia nella versione ventilata TEFC (servizio S1) che non ventilata TENV (servizio S3)
- Protezione termica PTO 150°C per le taglie motore 56 e 63.
- SMT56 e SMT63 adatti al funzionamento con alimentazione da inverter
- Disponibili nelle versioni autofrenante, servovenilata e con certificazione UL.

CMM gearmotors range has the following main features:

- *Compact design*
- *AC single phase and three phase motors available*
- *Motor extruded aluminum housing black anodized*
- *Gearbox die-cast aluminum housing*
- *AC electric motor in IP66 protection Standard*
- *Permanent synthetic oil long-life lubrication*
- *Fan cooled TEFC (duty S1) and not ventilated TENV (duty S3) versions available*
- *PTO 150°C thermal protection for motor sizes 56 and 63.*
- *SMT56 and SMT63 are suitable for inverter duty*
- *Brake motors, forced ventilation motors and UL compliance versions available.*

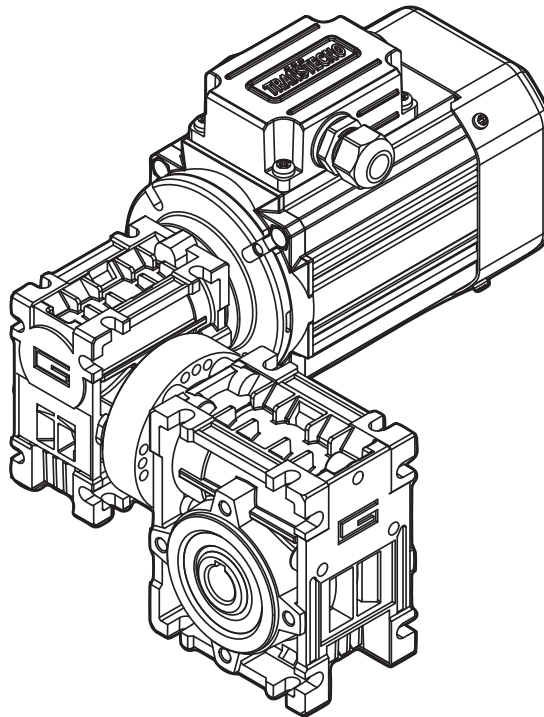

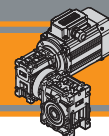

Designazione

Classification

RIDUTTORE / GEARBOX										
CMM	030/040	FD	150	63	B5	SZDX	BRSX	90	US1	VS
Tipo Type	Grandezza Size	Versione Version	Rapporto Ratio	IEC 	Forma costruttiva Version	Albero di uscita Output shaft	Braccio di reazione Torque arm	Angolo Angle	Esecuzione di montaggio Mounting execution	Opzioni Options
 CMM	026/026 026/026 (D11) 026/026 (D14) 026/030 026/040 030/040	U F...	vedi tabelle see tables	56.. 63..	B5 B14	SZDX SZSX DZ	BRDX BRSX *	0° 90° 180° 270°	UB1 UB2 US1 US2 UV1 UV2 UC1 UC2	VS1 VS2

NOTA: il braccio di reazione viene fornito smontato.

* NOTE: the torque arm will be supplied not assembled.

Versione Riduttore
Gearbox Version

U **F...D** **F...S**

Albero di uscita
Output shaft

SZDX **SZSX** **DZ**

Braccio di reazione
Torque arm

BRDX **BRSX**

Angolo
Angle

90° **90°**
180° **0°**
270° **270°**

MOTORE TRIFASE / THREE PHASE MOTOR										
SMT	63	2	4	0.18 kW	B14	230-400 V	50 Hz	TEFC	BR	T1
Tipo Type	Grandezza Size	Indicativo potenza Power coefficient	Poli Poles	Potenza Power	Forma costruttiva Version	Tensione Voltage	Frequenza Frequency	Ventilazione Fan cooling	Opzioni Options	Pos. Morsettiera Terminal box pos.
 SMT	Vedere tab. See tab.	1-2-3-4	4	0.04 kW ... 0.25 kW	B14	230-400 V 460V	50Hz 60Hz	TEFC TENV		T1 (Std)

MOTORE MONOFASE / SINGLE PHASE MOTOR										
SMM	63	2	4	0.18 kW	B14	230 V	50 Hz	TEFC	UL-CSA	T1
Tipo Type	Grandezza Size	Indicativo potenza Power coefficient	Poli Poles	Potenza Power	Forma costruttiva Version	Tensione Voltage	Frequenza Frequency	Ventilazione Fan cooling	Opzioni Options	Pos. Morsettiera Terminal box pos.
 SMM	Vedere tab. See tab.	1-2-3-4	4	0.04 kW ... 0.25 kW	B14	230V	50Hz	TEFC TENV		T1 (Std)

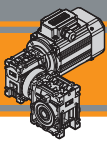
**Simbologia****Symbols**

n_1	[min ⁻¹]	Velocità in ingresso / <i>Input speed</i>
n_2	[min ⁻¹]	Velocità in uscita / <i>Output speed</i>
i		Rapporto di riduzione / <i>Ratio</i>
P_1	[kW]	Potenza in entrata / <i>Input power</i>

M_2	[Nm]	Coppia in uscita in funzione di P_1 / <i>Output torque referred to P_1</i>
sf		Fattore di servizio / <i>Service factor</i>
R_2	[N]	Carico radiale ammissibile in uscita / <i>Permitted output radial load</i>
A_2	[N]	Carico assiale ammissibile in uscita / <i>Permitted output axial load</i>

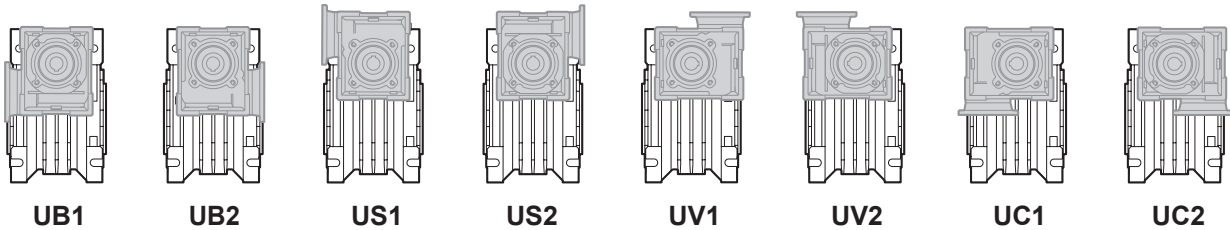
Esecuzioni di montaggio**Mounting executions****Combinazioni rapporti****Combination ratio**

CMM 026/026 - CMM 026/030 - CMM 026/040												
$i (i_1 \times i_2)$												
	150	225	300	450	600	900	1200	1500	1800	2400	3000	3600
i_1	10	15	10	15	20	30	40	50	60	60	60	60
i_2	15	15	30	30	30	30	30	30	30	40	50	60

CMM 030/040														
$i (i_1 \times i_2)$														
	150	200	250	300	400	500	600	750	900	1200	1500	1800	2400	3000
i_1	10	10	10	10	10	10	20	25	30	40	50	60	60	60
i_2	15	20	25	30	40	50	30	30	30	30	30	30	40	50

Lubrificazione**Lubrication**

Tutti i motoriduttori nelle taglie 26, 30, 40 sono forniti completi di lubrificante sintetico viscosità 320, pertanto possono essere installati in qualunque posizione di montaggio e non necessitano di manutenzione.

Permanent synthetic oil long-life lubrication (viscosity grade 320) makes it possible to use the gearmotors size 26, 30, 40 in all mounting positions; for this reason they can be installed in any assembly position and do not require maintenance.

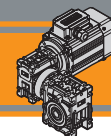

Dati tecnici

Technical data

P ₁ [kW]	n ₂ [min ⁻¹]	M ₂ [Nm]	sf	i		P ₁ [kW]	n ₂ [min ⁻¹]	M ₂ [Nm]	sf	i					
0.04						0.06									
SMT5014	9.3	23	1.1	150	CMM 026/026	SMT5024	9.3	33	0.8	150	CMM 026/026				
SMM5014	6.2	32	0.8	225		SMM5024	6.2	33	0.8	225					
(1400 min ⁻¹)	4.7	34	0.8	300			9.3	34	1.1	150	CMM 026/030				
	3.1	34	0.8	450			6.2	48	0.8	225					
	2.3	34	0.8	600			4.7	50	0.8	300					
	1.6	34	0.8	900			9.3	35	2.5	150	CMM 026/040				
	1.2	34	0.8	1200			6.2	50	1.8	225					
	0.9	34	0.8	1500			4.7	58	1.5	300					
	0.8	34	0.8	1800			3.1	82	1.1	450	CMM 030/040				
	0.6	28	0.8	2400			2.3	104	0.9	600					
	0.5	25	0.8	3000			1.6	113	0.8	900					
	0.4	23	0.8	3600			9.3	36	2.4	150	CMM 030/040				
	9.3	23	1.7	150	7.0		46	1.6	200						
	6.2	32	1.2	225	5.6		55	1.2	250						
	4.7	37	1.1	300	4.7	59	1.5	300							
	3.1	50	0.8	450	3.5	72	1.0	400							
	2.3	50	0.8	600	2.8	81	0.8	500							
	1.6	50	0.8	900	2.3	105	0.9	600							
	1.2	50	0.8	1200	1.9	113	0.8	750							
	0.9	50	0.8	1500	1.6	113	0.8	900							
	0.8	50	0.8	1800											
	0.6	43	0.8	2400											
	0.5	38	0.8	3000											
	0.4	34	0.8	3600											
	9.3	23	3.7	150	CMM 026/040	0.09									
	6.2	33	2.6	225	SMT5034	9.3	49	0.8	150	CMM 026/030					
	4.7	39	2.3	300	SMM5034	6.2	49	0.8	225						
	3.1	55	1.6	450	SMT5624		9.3	53	1.6	150	CMM 026/040				
	2.3	69	1.3	600	SMM5624							6.2	74	1.2	225
	1.6	92	1.0	900	(1400 min ⁻¹)							4.7	87	1.0	300
	1.2	113	0.8	1200								3.1	113	0.8	450
	0.9	113	0.8	1500	2.3							113	0.8	600	
	0.8	113	0.8	1800	9.3							53	1.6	150	CMM 030/040
	0.6	93	0.8	2400	7.0							69	1.1	200	
	0.5	85	0.8	3000	5.6							83	0.8	250	
	0.4	78	0.8	3600	4.7							88	1.0	300	
	9.3	24	3.7	150	3.5							93	0.8	400	CMM 030/040
	7.0	31	2.4	200	2.8							85	0.8	500	
	5.6	37	1.8	250	2.3							113	0.8	600	
	4.7	39	2.3	300											
	3.5	48	1.6	400											
	2.8	54	1.3	500											
	2.3	70	1.3	600											
	1.9	84	1.1	750											
	1.6	94	1.0	900											
	1.2	113	0.8	1200											
	0.9	113	0.8	1500											
	0.8	113	0.8	1800											
	0.6	93	0.8	2400											
	0.5	85	0.8	3000											

Nota: Verificare sempre che la coppia M2 utilizzata non ecceda il valore indicato nelle caselle in grigio

Note: Please check that the output torque M2 does not exceed the value into the grey areas



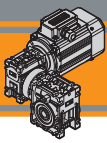

Motori Motors	SMT		SMM	
		5014 5024 5034	5624	5014 5024 5034
IEC	56 B14		56 B14	



Dati tecnici

Technical data

P ₁ [kW]	n ₂ [min ⁻¹]	M ₂ [Nm]	sf	i	
------------------------	--	------------------------	----	---	---

P ₁ [kW]	n ₂ [min ⁻¹]	M ₂ [Nm]	sf	i	
------------------------	--	------------------------	----	---	---

0.12

SMT5044	9.3	70	1.2	150	CMM 026/040
SMT5634	6.2	99	0.9	225	
SMM5634 (1400 min ⁻¹)	4.7	113	0.8	300	
	9.3	71	1.2	150	CMM 030/040
	7.0	92	0.8	200	
	5.6	84	0.8	250	
	4.7	113	0.8	300	

0.18

SMT6324	9.3	107	0.8	150	CMM 030/040
SMM6324 (1400 min ⁻¹)	7.0	93	0.8	225	
					

0.25

SMT5654	9.3	109	0.8	150	CMM 030/040
SMT6334					
SMM6334 (1400 min ⁻¹)					



0.18

SMT5644	9.3	105	0.8	150	CMM 026/040
SMM5644 (1400 min ⁻¹)	6.2	109	0.8	225	
	9.3	107	0.8	150	CMM 030/040
	7.0	93	0.8	200	

Nota: Verificare sempre che la coppia M2 utilizzata non ecceda il valore indicato nelle caselle in grigio

Note: Please check that the output torque M2 does not exceed the value into the grey areas



Motori Motors	SMT			SMM	
	5044	5644 5654	6324 6334	5634 5644	6324 6334
IEC	56 B14		63 B14	56 B14	63 B14

Dati tecnici elettrici

Electrical technical data



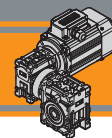

Motori applicabili

Motor adapters

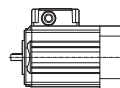
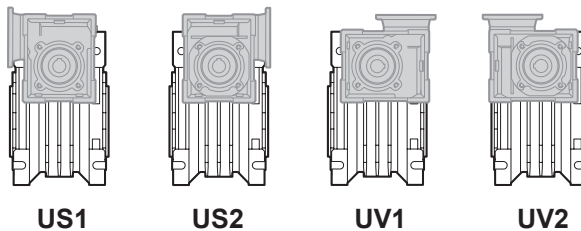

		SMT		SMM	
		5014	5624	5014	5624
		5024	5634	5024	5634
		5034	5644	5034	5644
		5044	5654		
CM	026/026	150 - 3600		150 - 3600	

150 - 3600 Rapporti di riduzione i / Ratio i

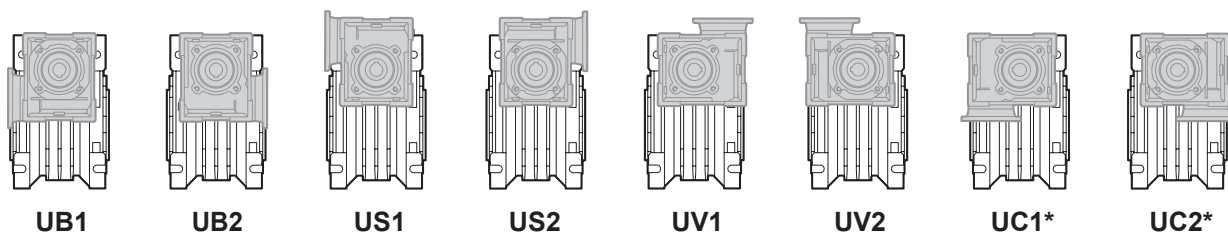

*: Solo / only SMT 50 - SMM50

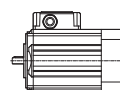

		SMT		SMM	
		5014	5624	5014	5624
		5024	5634	5024	5634
		5034	5644	5034	5644
		5044	5654		
CM	026/030 026/040	150 - 3600		150 - 3600	

150 - 3600 Rapporti di riduzione i / Ratio i

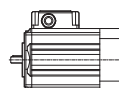
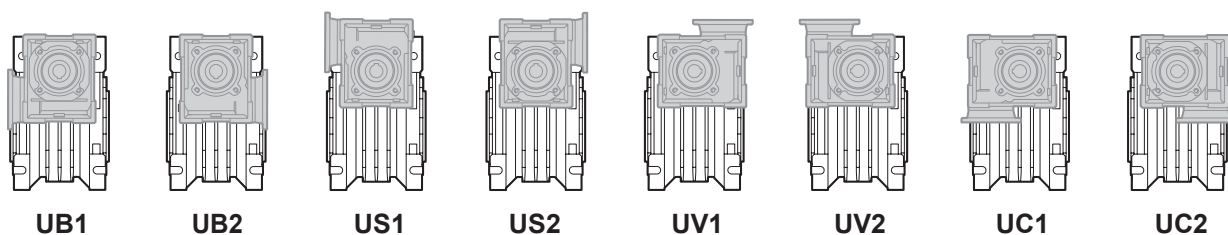

		SMT			SMM		
		5014	5624	6324	5014	5624	6314
		5024	5634	6334	5024	5634	6324
		5034	5644	6344	5034	5644	6334
		5044	5654				
CM	030/040	75 - 3600		75-1500	75 - 3600		75-1500

75 - 3600 Rapporti di riduzione i / Ratio i

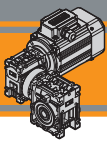

Dimensioni

Dimensions

CMM..U - CMM..F...																	
	A	C	D H8	E	F	G	G1	H	H1	I	I1	K	L	M	N h8	N1	N2
026/026 (D11)			11														
026/026	45	70	12	83	22	47.5	50	35	34	26	26	34	42	55	45	22.5	21
026/026 (D14)			14														
026/030	54	80	14	97	32	47.5	63	40	34	30	26	44	56	65	55	29	21
026/040	70	100	18	121.5	43	47.5	78	50	34	40	26	60	71	75	60	36.5	21

CMM..U - CMM..F...														
	O	P	Q	R	R1	S	T	V	Z	KE	a	b	t	Kg
026/026 (D11)												4	12.8	
026/026	6	—	37	49	49	5	15	21	76	7	—	4	13.8	1.6
026/026 (D14)												5	16.2	
026/030	6.5	75	44	57	49	5.5	22	27	81	M6x10(n.4)	90°	5	16.3	2.4
026/040	6.5	87	55	71.5	49	6.5	26	35	91.5	M6x8(n.4)	45°	6	20.8	3.5

	CMM..F						CMM..F28						CMM..F30						CMM..F30S ⁽¹⁾														
	a1	KA	KB	KC	KM	KN H8	KO	KP	KQ	KA	KB	KC	KM	KN H8	KO	KP	KQ	KA	KB	KC	KM	KN H8	KO	KP	KQ	KA	KB	KC	KM	KN H8	KO	KP	KQ
026 (D11)	45°	45	6	4.5	55-69	40	6.5 (n.4)	75	70	44	6.5	5	56-64	40	6.5	70	60	48	6.5	5	68	50	6.5	80	70	50	8.5	7	68	50	6.5	80	70
026																																	
026 (D14)																																	

(1): F30S eseguita con F30 e distanziale di spessore 2 mm / F30S made with F30 and spacer with 2mm thickness

	CMM..F30C						CMM..F30SC ⁽²⁾						CMM..F100												
	a1	KA	KB	KC	KM	KN H8	KO	KP	KQ	KA	KB	KC	KM	KN H8	KO	KP	KQ	KA	KB	KC *	KM	KN h7	KO	KP	KQ
026 (D11)	-	48	6.5	7	68	50	6.5	80	70	50	8.5	7	68	50	6.5	80	70	51.5	8	2 *	86	45	6.5	100	-
026																									
026 (D14)																									

(2): F30SC eseguita con F30C e distanziale di spessore 2 mm / F30SC made with F30C and spacer with 2mm thickness

	CMM..F						CMM..FB						CMM..FL												
	a1	KA	KB	KC	KM	KN H8	KO	KP	KQ	KA	KB	KC	KM	KN H8	KO	KP	KQ	KA	KB	KC	KM	KN H8	KO	KP	KQ
026/030	45°	54.5	6	4	68	50	6.5(n.4)	80	70								—								
026/040	45°	67	7.5	4.5	80-95	60	9(n.4)	110	95	80	8.5	5	115-125	95	9.5(n.4)	140	112	97	7.5	4.5	80-95	60	9(n.4)	110	95

SMT	BFC	BNV	LFC	LNV
5014	□ 85	□ 80	135.5	108.5
5024			150.5	123.5
5034			175.5	148.5
5044			200.5	173.5
5624	□ 93	□ 87	141	117
5634			151	127
5644			186	162
5654			206	182

SMM	BFC	BNV	LFC	LNV
5014	□ 85	□ 80	150.5	123.5
5024			175.5	148.5
5034			200.5	173.5
5624			151	127
5634	□ 93	□ 87	186	162
5644			206	182

Nota: il condensatore sarà fornito a corredo
Note: the capacitor will be supplied separately

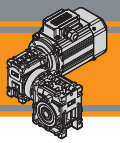

Dimensioni

Dimensions

CMM 026/... U

S3 ^{servizio} _{duty} 30%

SMT...TENV
SMM... TENV

SMT...TEFC
SMM... TEFC

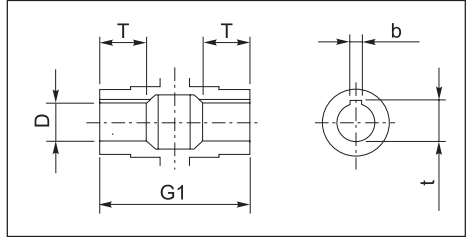
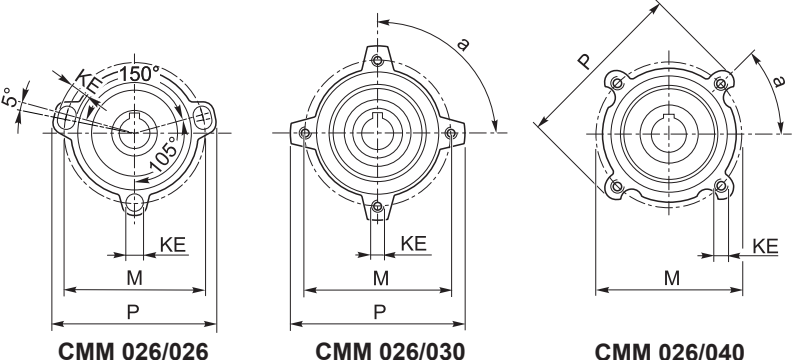
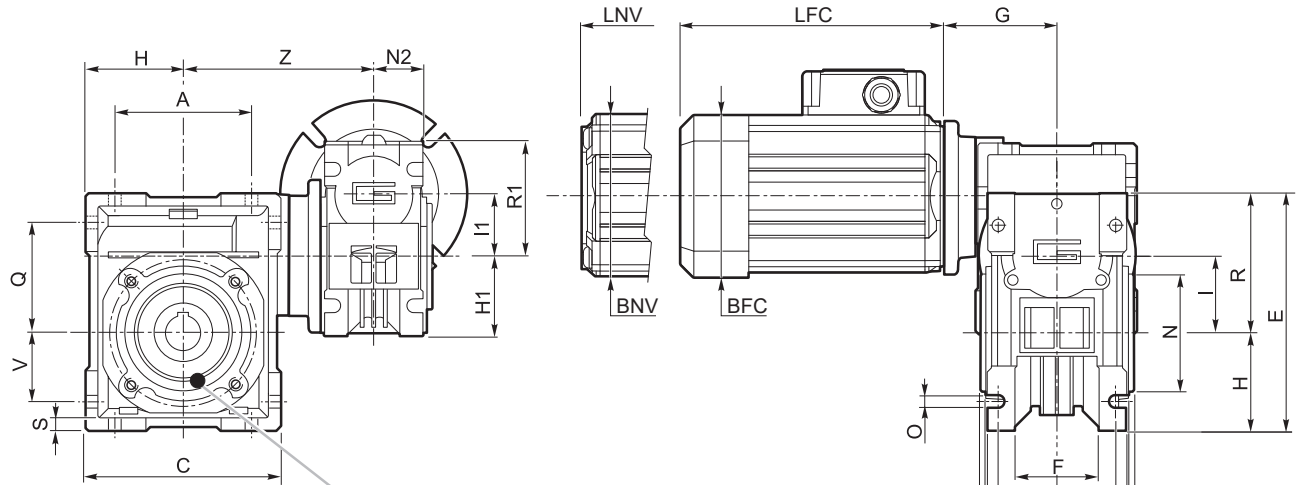

Albero lento cavo / Hollow output shaft

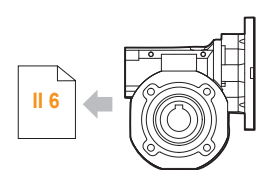
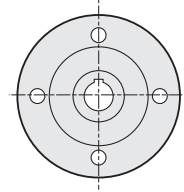
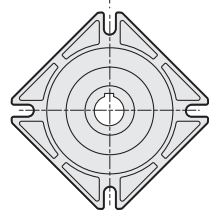
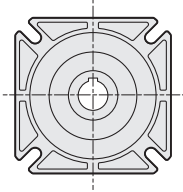
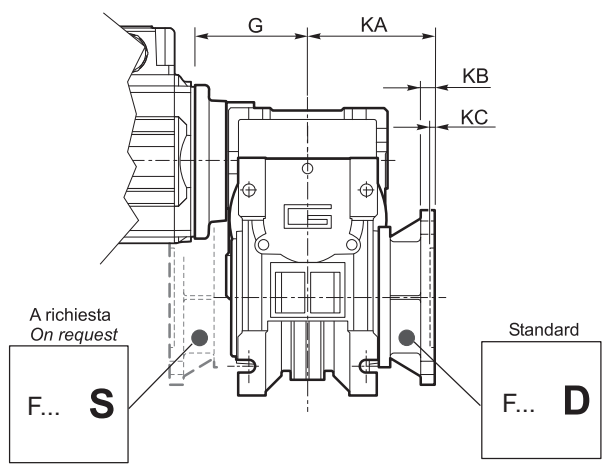
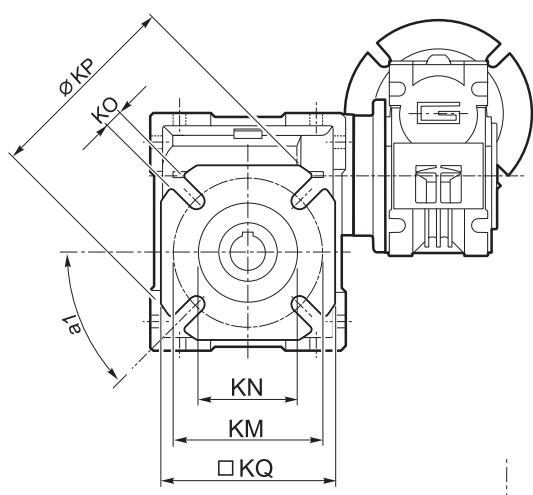

- CMM026/026.. F
- CMM026/026.. F28
- CMM026/026.. F30
- CMM026/026.. F30S
- CMM026/030.. F..
- CMM026/040.. F..

- CMM026/026.. F30C
- CMM026/026.. F30SC

- CMM026/026.. F100

- CL026
- CL030
- CL040

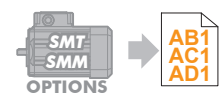

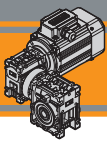

Dimensioni

Dimensions

CMM.. - CMM..F - CMM..FB - CMM..FL																	
	A	C	D _{H8}	E	F	G	G1	H	H1	I	I1	K	L	M	N _{H8}	N1	N2
030/040	70	100	18	121.5	43	55	78	50	40	40	30	60	71	75	60	36.5	29

CMM.. - CMM..F - CMM..FB - CMM..FL															
	O	P	Q	R	R1	S	T	V	Z	KE	a	b	t	Kg	
030/040	6.5	87	55	71.5	57	6.5	26	35	122	M6x8(n.4)	45°	6	20.8 (21.8)	3.9	

	CMM..F								CMM..FB								CMM..FL								
	a1	KA	KB	KC	KM	KN _{H8}	KO	KP	KQ	KA	KB	KC	KM	KN _{H8}	KO	KP	KQ	KA	KB	KC	KM	KN _{H8}	KO	KP	KQ
030/040	45°	67	7.5	4	80-95	60	9(n.4)	110	95	80	8.5	5	115-125	95	9.5(n.4)	140	112	97	7.5	4.5	80-95	60	9(n.4)	110	95

SMT	BFC	BNV	LFC	LNv
5014	□ 85	□ 80	135.5	108.5
5024			150.5	123.5
5034			175.5	148.5
5044			200.5	173.5
5624	□ 93	□ 87	141	117
5634			151	127
5644			186	162
5654			206	182
6324	□ 105	□ 97	165.5	138.5
6334			180.5	153.5
6344			205.5	178.5

SMM	BFC	BNV	LFC	LNv
5014	□ 85	□ 80	150.5	123.5
5024			175.5	148.5
5034			200.5	173.5
5624	□ 93	□ 87	151	127
5634			186	162
5644			206	182
6324	□ 105	□ 97	180.5	153.5
6334			205.5	178.5

Nota: il condensatore sarà fornito a corredo
Note: the capacitor will be supplied separately

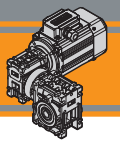

Dimensioni

Dimensions

CMM 030/040 U

S3 servizio duty

30%

SMT...TENV
SMM... TENV

SMT...TEFC
SMM... TEFC

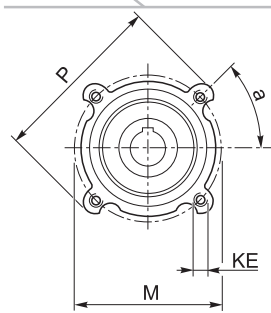
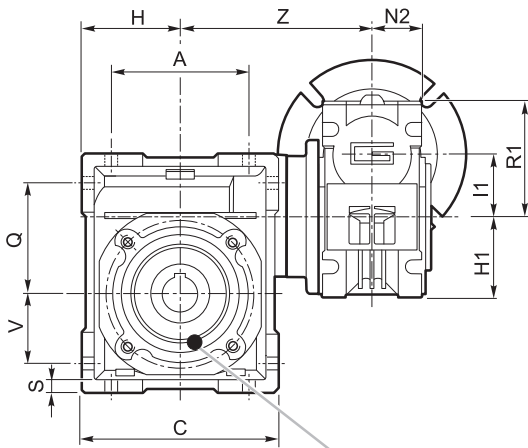

CMM 030/040

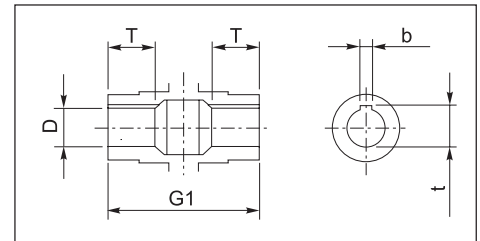
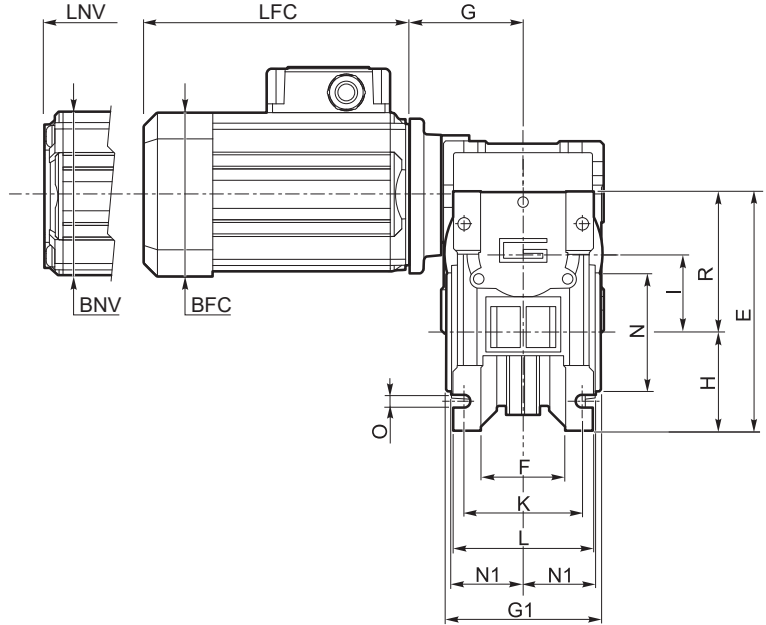

Albero lento cavo / Hollow output shaft

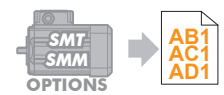
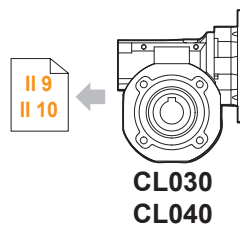
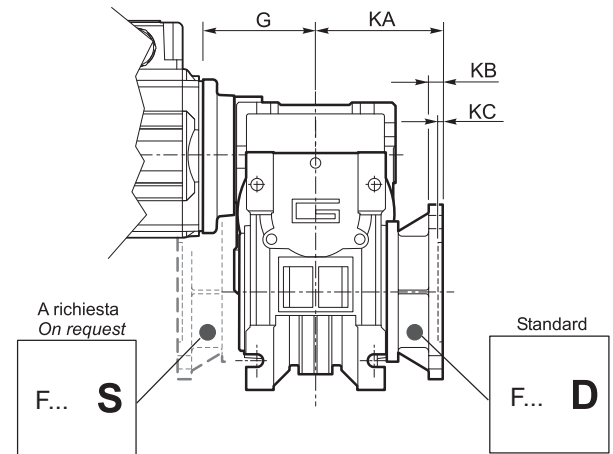
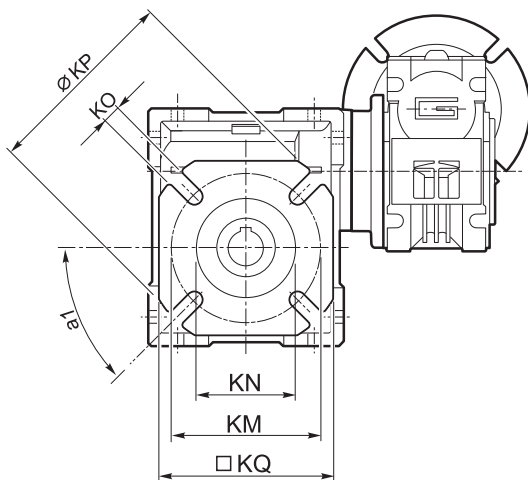

AC

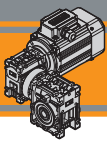

Opzioni

Options

VS1 - VS2 - Vite sporgente / Extended input shaft

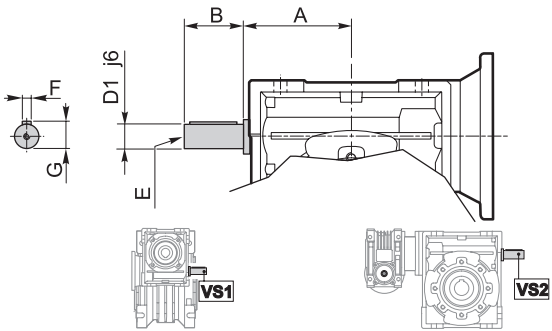

CMM	VS1						VS2					
	A	B	D ₁ j6	E	F	G	A	B	D ₁ j6	E	F	G
026/030	—	—	—	—	—	—	45	20	9	M4	3	10.2
026/040	—	—	—	—	—	—	53	23	11	M5	4	12.5
030/040	45	20	9	M4	3	10.2	53	23	11	M5	4	12.5

Costruito su richiesta
Built on request

Accessori

Accessories

Albero lento semplice e doppio

Single and double output shaft

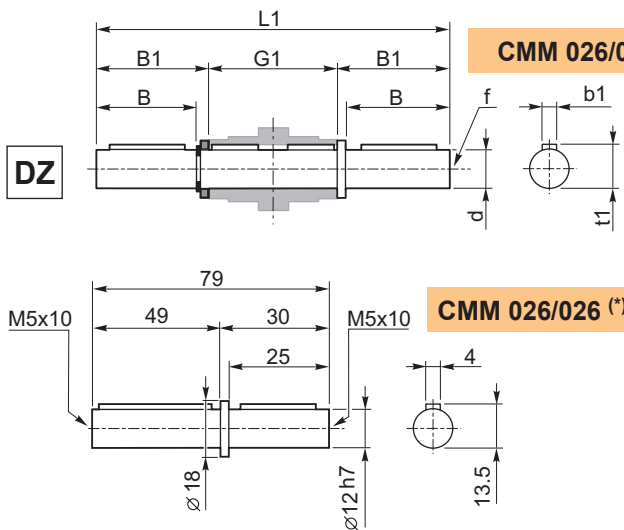

CMM 026/030 - CMM 030/040

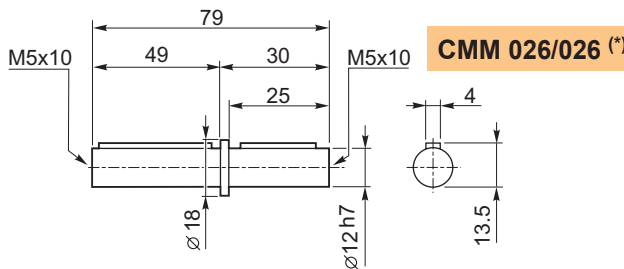
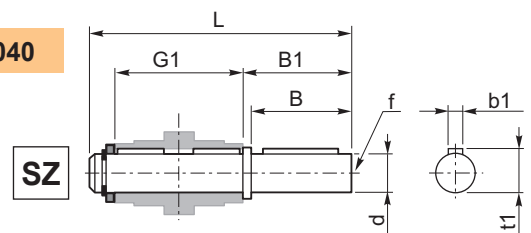

CMM 026/026 (*)

CMM	d h7	B	B1	G1	L	L1	f	b1	t1
026/030	14	30	32.5	63	102	128	M6	5	16
026/040 030/040	18	40	43	78	128	164	M6	6	20.5

(*)
Nota: disponibile solo per cavo uscita Ø12
Note: available for output hollow shaft Ø12 only

Braccio di reazione

Torque arm

CMM	K1	G	KG	KH	R
026/030	85	14	23	8	15
026/040 030/040	100	14	31	10	18

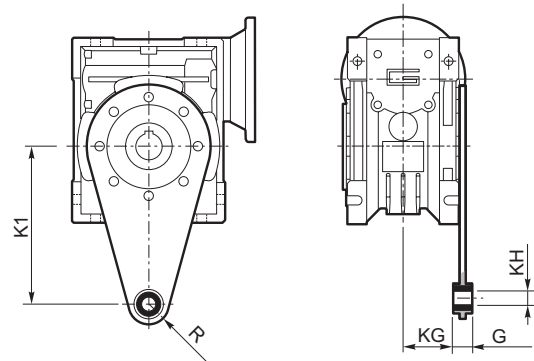

SC - Safety cover

WD - Kit washdown cover

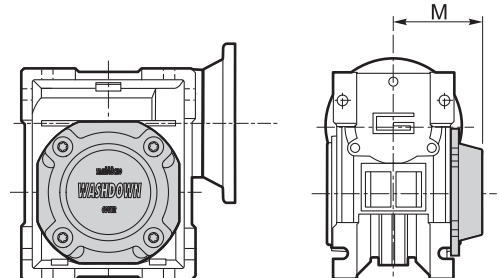
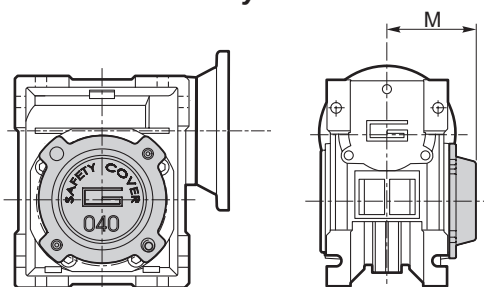

M	CM	
	30	40
M	47	54.5

M	CM	
	30	40
M	48	55.5

MINI  **TECNO**™
small but strong

PM

AC

Motoriduttori CA epicicloidali
AC Planetary gearmotors



MINI  **TECNO**™ brand of
TRANSTECNO®



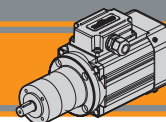

Indice	Index	Pag. Page
Caratteristiche tecniche	<i>Technical features</i>	AL2
Designazione	<i>Classification</i>	AL2
Versioni	<i>Versions</i>	AL2
Simbologia	<i>Symbols</i>	AL3
Lubrificazione	<i>Lubrication</i>	AL3
Carichi radiali	<i>Radial loads</i>	AL3
Rapporti	<i>Ratios</i>	AL3
Dati tecnici	<i>Technical data</i>	AL4
Motori applicabili	<i>IEC Motor adapters</i>	AL8
Dimensioni	<i>Dimensions</i>	AL8

Questa sezione annulla e sostituisce ogni precedente edizione o revisione. Qualora questa sezione non Vi sia giunta in distribuzione controllata, l'aggiornamento dei dati ivi contenuto non è assicurato. **In tal caso la versione più aggiornata è disponibile sul nostro sito internet www.transtecno.com**

This section replaces any previous edition and revision. If you obtained this catalogue other than through controlled distribution channels, the most up to date content is not guaranteed. In this case the latest version is available on our web site www.transtecno.com

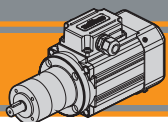

PM

Motoriduttori CA epicicloidali
AC planetary gearmotors



Caratteristiche tecniche

Technical features

Le caratteristiche principali dei motoriduttori PM sono:

- Costruzione compatta
- Motorizzazioni in corrente alternata monofase e trifase
- Carcassa motore estrusa in alluminio anodizzato nero
- Motore elettrico AC con grado di protezione IP66
- Disponibili sia nella versione ventilata TEFC (servizio S1) che non ventilata TENV (servizio S3)
- Protezione termica PTO 150°C per le taglie motore 56 e 63.
- SMT56 e SMT63 adatti al funzionamento con alimentazione da inverter
- Disponibili nelle versioni autofrenante, servoventilata e con certificazione UL.

PM gearmotors gearmotors have the following main features:

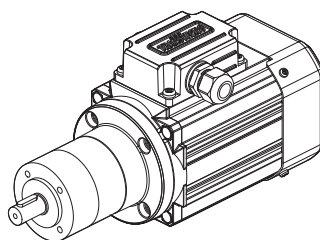

- Compact design
- AC single phase and three phase motors available
- Motor extruded aluminum housing black anodized
- AC electric motor in IP66 protection Standard
- Fan cooled TEFC (duty S1) and not ventilated TENV (duty S3) versions available
- PTO 150°C thermal protection for motor sizes 56 and 63.
- SMT56 and SMT63 are suitable for inverter duty
- Brake motors, forced ventilation motors and UL compliance versions available.



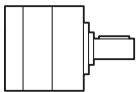

Designazione

Classification

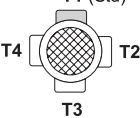
RIDUTTORE / GEARMOTOR				
PM	52	2	C80	34.97
Tipo Type	Grandezza Size	Stadi riduttore Gearbox stages	Versione riduttore Gearbox Version	Rapporto Ratio
PM 	52 62	1 2 3	U C80 C90 C105 C120	Vedere tabella See tables

MOTORE TRIFASE / THREE PHASE MOTOR										
SMT	63	2	4	0.18 kW	B14	230-400 V	50 Hz	TEFC	BR	T1
Tipo Type	Grandezza Size	Indicativo potenza Power coefficient	Poli Poles	Potenza Power	Forma costruttiva Version	Tensione Voltage	Frequenza Frequency	Ventilazione Fan cooling	Opzioni Options	Pos. Morsettiera Terminal box pos.
SMT 	Vedere tab. See tab.	1-2-3-4-5	4	0.04 kW ... 0.37 kW	B14	230-400 V 460V	50Hz 60Hz	TEFC TENV		T1 (Std) 

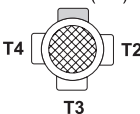
MOTORE MONOFASE / SINGLE PHASE MOTOR										
SMM	63	2	4	0.18 kW	B14	230 V	50 Hz	TEFC	UL-CSA	T1
Tipo Type	Grandezza Size	Indicativo potenza Power coefficient	Poli Poles	Potenza Power	Forma costruttiva Version	Tensione Voltage	Frequenza Frequency	Ventilazione Fan cooling	Opzioni Options	Pos. Morsettiera Terminal box pos.
SMM 	Vedere tab. See tab.	1-2-3-4	4	0.04 kW ... 0.25 kW	B14	230V	50Hz	TEFC TENV		T1 (Std) 

Versioni

Versions

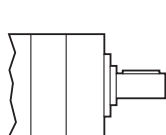

U

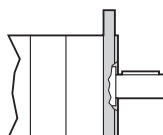

C

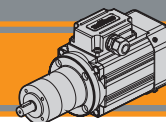

Simbologia

Symbols

n_1 [min ⁻¹]	Velocità in ingresso / <i>Input speed</i>	sf	Fattore di servizio / <i>Service factor</i>
n_2 [min ⁻¹]	Velocità in uscita / <i>Output speed</i>	Rd %	Rendimento dinamico / <i>Dynamic efficiency</i>
i	Rapporto di riduzione / <i>Ratio</i>	A_2 [N]	Carico assiale ammissibile in uscita / <i>Permitted output axial load</i>
P_1 [kW]	Potenza in entrata / <i>Input power</i>	R_2 [N]	Carico radiale ammissibile in uscita / <i>Permitted output radial load</i>
M_2 [Nm]	Coppia in uscita in funzione di P_1 / <i>Output torque referred to P_1</i>		

Lubrificazione

Lubrication

I riduttori epicicloidali sono lubrificati in modo permanente, non richiedono quindi ulteriore manutenzione. Questo gli consente di essere installati praticamente ovunque.

Planetary gearboxes are life-time lubricated with grease, therefore they are maintenance free. They can be installed in any location.

Carichi radiali

Radial loads

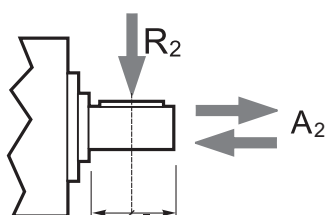

Numero di stadi Stages number	Carichi Radiali R_2 [N] / <i>Radial Load R_2 [N]</i>	
	PM52	PM62
1	200	240
2	320	360
3	450	520

Numero di stadi Stages number	Carichi Assiali A_2 [N] / <i>Axial Load A_2 [N]</i>	
	PM52	PM62
1	60	70
2	100	100
3	150	150

Rapporti



Ratios

Numero di stadi Stages number	Per tutte le grandezze di riduttori della serie PM <i>For all gearbox sizes of PM range</i>	
	Rapporti / <i>Ratios</i>	
1	3.70	
	4.28	
	5.18	
	6.75	
2	13.73	
	15.88	
	18.36	
	19.20	
	22.20	
	25.01	
	26.85	
	28.93	
	34.97	
	45.56	
3	50.89	
	58.85	
	68.06	
	71.16	
	78.71	
	92.70	
	95.17	
	99.50	
	107.20	
	115.07	
	123.97	
	129.62	
	139.13	
	149.90	
	168.84	
181.24		
195.26		
236.09		
307.54		

Rapporti preferenziali per le taglie PM52, PM62.
Preferred ratios for PM52, PM62.

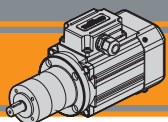
Disponibile a 4 stadi con rapporti fino a 2076
Available 4 stages with ratio up to 2076

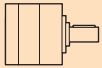
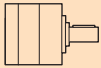
**PM****Motoriduttori CA epicicloidali
AC planetary gearmotors****MINI
TECNO****Dati tecnici****Technical data**

P_1 [kW]	n_2 [min ⁻¹]	M_2 [Nm]	sf	i		P_1 [kW]	n_2 [min ⁻¹]	M_2 [Nm]	sf	i		
0.04						0.04						
SMT5014	378	0.8	6.3	3.7	PM521	SMT5014	28	10	6.5	50.89	PM623	
SMM5014	327	0.9	5.4	4.28		SMM5014	24	11	5.6	58.85		
(1400 min ⁻¹)	270	1.1	4.5	5.18		(1400 min ⁻¹)	21	13	4.9	68.06		
	207	1.5	3.4	6.75			20	14	4.7	71.16		
	102	3	5.4	13.73	PM522		18	15	4.2	78.71		
	88	3	4.7	15.88			15	18	3.6	92.7		
	76	4	4.0	18.36			15	18	3.5	95.17		
	73	4	3.9	19.2			14	19	3.3	99.5		
	63	5	3.3	22.2			13	20	3.1	107.2		
	56	5	3.0	25.01			12	22	2.9	115.07		
	52	5	2.8	26.85			11	24	2.7	123.97		
	48	6	2.6	28.93			11	25	2.6	129.62		
	40	7	2.1	34.97			10	27	2.4	139.13		
	31	9	1.6	45.56			9.3	29	2.2	149.9		
						PM523		8.3	32	2.0	168.84	
	28	10	3.3	50.89				7.7	35	1.8	181.24	
	24	11	2.8	58.85			7.2	37	1.7	195.26		
	21	13	2.4	68.06			5.9	45	1.4	236.09		
	20	14	2.3	71.16			4.6	59	1.1	307.54		
	18	15	2.1	78.71								
	15	18	1.8	92.7								
	15	18	1.7	95.17								
	14	19	1.7	99.5								
	13	20	1.5	107.2								
	12	22	1.4	115.07								
	11	24	1.3	123.97								
	11	25	1.3	129.62								
	10	27	1.2	139.13								
	9.3	29	1.1	149.9								
	8.3	32	1.0	168.84								
	7.7	35	0.9	181.24								
	7.2	37	0.8	195.26								
	5.9	45	0.7	236.09								
	4.6	45	0.7	307.54								
					PM622							
	56	5	6.2	25.01								
	52	5	5.8	26.85								
	48	6	5.3	28.93								
	40	7	4.4	34.97								
	31	9	3.4	45.56								
						PM522						
	102	4	3.6	13.73								
	88	5	3.1	15.88								
	76	6	2.7	18.36								
	73	6	2.6	19.2								
	63	7	2.2	22.2								
	56	8	2.0	25.01								
	52	8	1.8	26.85								
	48	9	1.7	28.93								
	40	11	1.4	34.97								
	31	14	1.1	45.56								
					PM523							
	28	15	2.2	50.89								
	24	17	1.9	58.85								
	21	19	1.6	68.06								
	20	20	1.6	71.16								
	18	23	1.4	78.71								
	15	27	1.2	92.7								
	15	27	1.2	95.17								
	14	29	1.1	99.5								
	13	31	1.0	107.2								
	12	33	1.0	115.07								
	11	36	0.9	123.97								
	11	37	0.9	129.62								
	10	40	0.8	139.13								
	9.3	45	0.7	149.9								
	8.3	45	0.7	168.84								
	7.7	45	0.7	181.24								
	7.2	45	0.7	195.26								

Motoriduttori preferenziali / Preferred gearmotors

NOTA
Per sf=0.7 verificare che la coppia utilizzata non
ecceda il valore M2 indicato.

NOTE
For sf=0.7 check that the duty torque does not
exceed the value M2



Motori Motors	SMT	SMM
	5014 5024	5014 5024
IEC	56 B14	56 B14

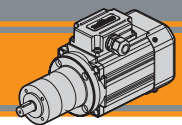

Dati tecnici

Technical data

P ₁ [kW]	n ₂ [min ⁻¹]	M ₂ [Nm]	sf	i		P ₁ [kW]	n ₂ [min ⁻¹]	M ₂ [Nm]	sf	i	
0.06						0.09					
SMT5024	56	8	4.1	25.01	PM622	SMT5034	56	12	2.7	25.01	PM622
SMM5024	52	8	3.8	26.85		SMM5034	52	12	2.6	26.85	
(1400 min ⁻¹)	48	9	3.6	28.93		SMT5624	48	13	2.4	28.93	
	40	11	2.9	34.97		SMM5624	40	16	2.0	34.97	
	31	14	2.3	45.56		(1400 min ⁻¹)	31	21	1.5	45.56	
	28	15	4.3	50.89	PM623		28	22	2.9	50.89	PM623
	24	17	3.8	58.85			24	25	2.5	58.85	
	21	19	3.2	68.06			21	29	2.2	68.06	
	20	20	3.1	71.16			20	31	2.1	71.16	
	18	23	2.8	78.71			18	34	1.9	78.71	
	15	27	2.4	92.7			15	40	1.6	92.7	
	15	27	2.3	95.17			15	41	1.5	95.17	
	14	29	2.2	99.5			14	43	1.5	99.5	
	13	31	2.1	107.2			13	46	1.4	107.2	
	12	33	1.9	115.07			12	49	1.3	115.07	
	11	36	1.8	123.97			11	53	1.2	123.97	
	11	37	1.7	129.62			11	56	1.1	129.62	
	10	40	1.6	139.13			10	60	1.1	139.13	
	9.3	43	1.5	149.9			9.3	64	1.0	149.9	
	8.3	48	1.3	168.84			8.3	73	0.9	168.84	
	7.7	52	1.2	181.24		7.7	78	0.8	181.24		
	7.2	56	1.1	195.26		7.2	84	0.8	195.26		
	5.9	68	0.9	236.09		5.9	90	0.7	236.09		
	4.6	88	0.7	307.54		4.6	90	0.7	307.54		

0.09						0.12						
SMT5034	378	2	2.8	3.7	PM521	SMT5044	378	2	2.1	3.7	PM521	
SMM5034	327	2	2.4	4.28		SMT5634	327	3	1.8	4.28		
SMT5624	270	3	2.0	5.18		SMM5634	270	3	1.5	5.18		
SMM5624	207	3	1.5	6.75		(1400 min ⁻¹)	207	4	1.1	6.75		
(1400 min ⁻¹)	102	6	2.4	13.73	PM522		102	8	1.8	13.73	PM522	
	88	7	2.1	15.88			88	10	1.6	15.88		
	76	8	1.8	18.36			76	11	1.3	18.36		
	73	9	1.7	19.2			73	12	1.3	19.2		
	63	10	1.5	22.2			63	14	1.1	22.2		
	56	12	1.3	25.01			56	15	1.0	25.01		
	52	12	1.2	26.85			52	16	0.9	26.85		
	48	13	1.1	28.93			48	18	0.9	28.93		
	40	16	0.9	34.97			40	22	0.7	34.97		
	31	21	0.7	45.56			31	22	0.7	45.56		
	28	22	1.4	50.89		PM523						
	24	25	1.3	58.85								
	21	29	1.1	68.06								
	20	31	1.0	71.16								
	18	34	0.9	78.71								
	15	40	0.8	92.7								
	15	41	0.8	95.17								
	14	45	0.7	99.5								
	13	45	0.7	107.2								
	12	45	0.7	115.07								
	11	45	0.7	123.97								
	11	45	0.7	129.62								
	10	45	0.7	139.13								

NOTA
Per sf=0.7 verificare che la coppia utilizzata non ecceda il valore M2 indicato.





NOTE
For sf=0.7 check that the duty torque does not exceed the value M2

Motoriduttori preferenziali / Preferred gearmotors

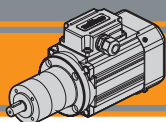

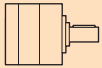
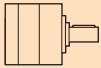
Motori Motors	SMT		SMM	
		5014 5024 5034 5044	5624 5634	5024 5034
IEC	56 B14		56 B14	

**PM****Motoriduttori CA epicicloidali
AC planetary gearmotors****MINI
TECNO****Dati tecnici****Technical data**

P_1 [kW]	n_2 [min ⁻¹]	M_2 [Nm]	sf	i		P_1 [kW]	n_2 [min ⁻¹]	M_2 [Nm]	sf	i		
0.12						0.18						
SMT5044	28	29	1.1	50.89	PM523	SMT5644	378	4	1.4	3.7	PM521	
SMT5634	24	34	0.9	58.85		SMM5644	327	4	1.2	4.28		
SMM5634	21	39	0.8	68.06		(1400 min ⁻¹)	270	5	1.0	5.18		
(1400 min ⁻¹)	20	41	0.8	71.16			207	7	0.8	6.75		
	18	45	0.7	78.71		102	13	1.2	13.73	PM522		
15	45	0.7	92.7	88		15	1.0	15.88				
15	45	0.7	95.17	76		17	0.9	18.36				
14	45	0.7	99.5	73		18	0.9	19.2				
13	45	0.7	107.2	63		22	0.7	22.2				
12	45	0.7	115.07	56		22	0.7	25.01				
11	45	0.7	123.97	52	22	0.7	26.85					
11	45	0.7	129.62	48	22	0.7	28.93					
10	45	0.7	139.13									
	378	2	4.2	3.7	PM621	28	45	0.7	50.89	PM523		
	327	3	3.6	4.28		24	45	0.7	58.85			
	270	3	3.0	5.18		21	45	0.7	68.06			
	207	4	2.3	6.75		20	45	0.7	71.16			
	102	8	3.8	13.73	PM622	0.18						
	88	10	3.2	15.88		SMT5644	378	4	2.8	3.7	PM621	
	76	11	2.8	18.36		SMM5644	327	4	2.4	4.28		
	73	12	2.7	19.2		SMT6324	270	5	2.0	5.18		
	63	14	2.3	22.2		SMM6324	207	7	1.5	6.75		
	56	15	2.1	25.01		(1400 min ⁻¹)	102	13	2.5	13.73		PM622
	52	16	1.9	26.85			88	15	2.2	15.88		
	48	18	1.8	28.93		76	17	1.9	18.36			
	40	21	1.5	34.97		73	18	1.8	19.2			
	31	28	1.1	45.56		63	20	1.5	22.2			
					56	23	1.4	25.01				
	28	29	2.2	50.89	52	25	1.3	26.85	PM623			
	24	34	1.9	58.85	48	27	1.2	28.93				
	21	39	1.6	68.06	40	32	1.0	34.97				
	20	41	1.6	71.16	31	42	0.8	45.56				
	18	45	1.4	78.71								
	15	53	1.2	92.7	28	44	1.4	50.89				
	15	55	1.2	95.17	24	51	1.3	58.85				
	14	57	1.1	99.5	21	58	1.1	68.06				
	13	61	1.0	107.2	20	61	1.0	71.16				
	12	66	1.0	115.07	18	68	0.9	78.71				
	11	71	0.9	123.97	15	80	0.8	92.7				
	11	74	0.9	129.62	15	82	0.8	95.17				
	10	80	0.8	139.13	14	86	0.7	99.5				
	9.3	90	0.7	149.9	13	90	0.7	107.2				
	8.3	90	0.7	168.84	12	90	0.7	115.07				
	7.7	90	0.7	181.24	11	90	0.7	123.97				
	7.2	90	0.7	195.26	11	90	0.7	129.62				
					10	90	0.7	139.13				

NOTA
Per sf=0.7 verificare che la coppia utilizzata non ecceda il valore M2 indicato.

NOTE
For sf=0.7 check that the duty torque does not exceed the value M2

 Motoriduttori preferenziali / Preferred gearmotors

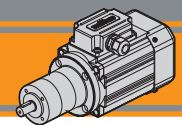

Motori Motors	SMT			SMM	
	5044	5634 5644	6324	5634 5644	6324
IEC	56 B14			63 B14	

Dati tecnici
Technical data

P_1 [kW]	n_2 [min ⁻¹]	M_2 [Nm]	sf	i		P_1 [kW]	n_2 [min ⁻¹]	M_2 [Nm]	sf	i	
0.25						0.37					
SMT5654 (1400 min ⁻¹)	378	4	1.4	3.7	PM521	SMT6344 (1400 min ⁻¹)	378	7	1.4	3.7	PM621
	327	4	1.2	4.28		327	9	1.2	4.28		
	270	5	1.0	5.18		270	10	1.0	5.18		
	207	7	0.8	6.75		207	14	0.7	6.75		
	102	18	0.9	13.73	PM522	102	26	1.2	13.73	PM622	
	88	20	0.7	15.88		88	30	1.1	15.88		
	76	22	0.7	18.36		76	35	0.9	18.36		
	73	22	0.7	19.2		73	36	0.9	19.2		
						63	42	0.8	22.2		
					56	45	0.7	25.01	PM623		
					52	45	0.7	26.85			
					48	45	0.7	28.93			
						28	90	0.7	50.89	PM623	
					24	90	0.7	58.85			
					21	90	0.7	68.06			
					20	90	0.7	71.16			

NOTA
Per sf=0.7 verificare che la coppia utilizzata non ecceda il valore M2 indicato.

Motoriduttori preferenziali / Preferred gearmotors

NOTE
For sf=0.7 check that the duty torque does not exceed the value M2



Motori Motors	SMT		SMM
		5654	6334 6344
IEC	56 B14	63 B14	63 B14

Dati tecnici elettrici
Electrical technical data

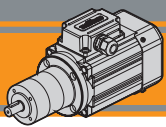
Motori applicabili

IEC Motor adapters

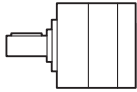
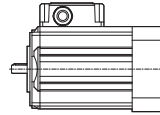

		SMT		SMM		SMT		SMM	
		5014	5624	5014	5624	6324		6324	
		5024	5634	5024	5634	6334		6334	
		5034	5644	5034	5644	6344			
		5044	5654						
PM	52...								
	62...								



Flangia di combainazione
Combination flange

Dimensioni

Dimensions

PM52 ... U

S3 servizio duty 30% SMT50...TENV SMM50... TENV

SMT50...TEFC SMM50... TEFC

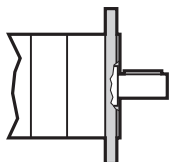
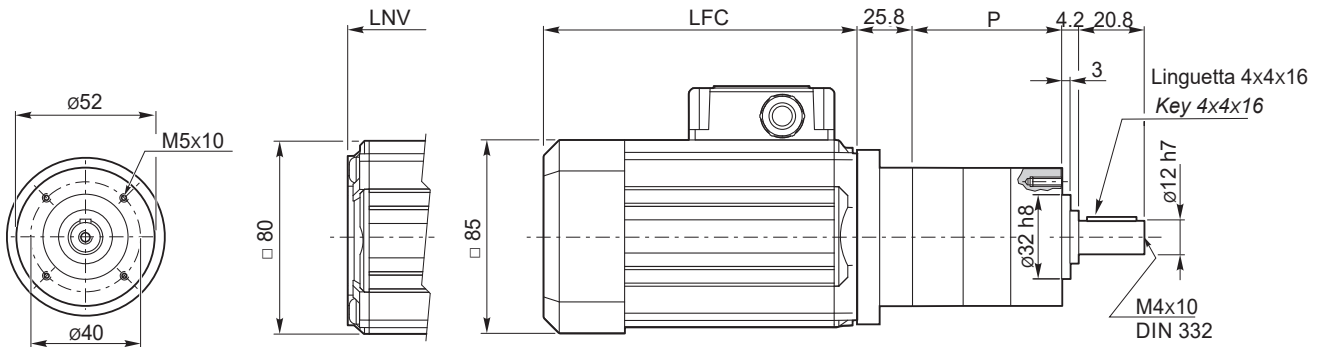

PM52...C



Tipo Type	Numero di stadi Stages number	P
PM52...	1	47.2
	2	61.3
	3	75.6

SMT	LFC	LNv	Kg	
5014	135.5	108.5	3.4	
5024	150.5	123.5	3.8	
5034	175.5	148.5	4.6	
5044	200.5	173.5	5.3	

SMM	LFC	LNv	Kg	
5014	150.5	123.5	3.8	
5024	175.5	148.5	4.6	
5034	200.5	173.5	5.3	

Nota: il condensatore sarà fornito a corredo
Note: the capacitor will be supplied separately

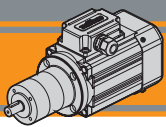

PM

Motoriduttori CA epicicloidali
AC planetary gearmotors

MINI
TECNO

Dimensioni

Dimensions

PM62 ... U

S3 servizio 30%
duty

SMT56...TENV
SMM56... TENV

SMT56...TEFC
SMM56... TEFC

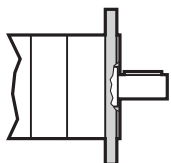
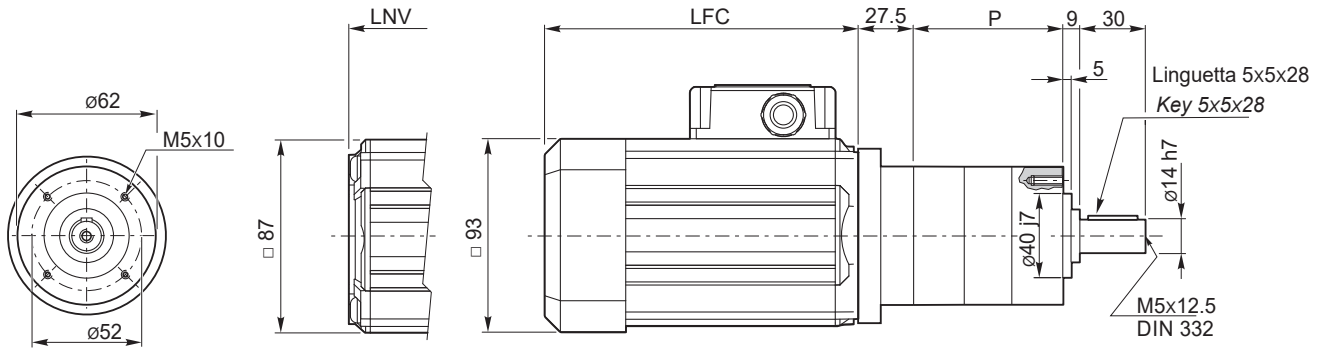

PM62...C

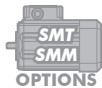

Tipo Type	Numero di stadi Stages number	P
PM62...	1	45.3
	2	62.2
	3	79.2

SMT	LFC	LNV	Kg	
5624	141	117	4.4	
5634	151	127	4.8	
5644	186	162	6	
5654	206	182	6.7	

SMM	LFC	LNV	Kg	
5624	151	127	4.7	
5634	171	147	5.3	
5644	206	182	6.6	

Nota: il condensatore sarà fornito a corredo
Note: the capacitor will be supplied separately

PM62 ... U

S3 servizio 30%
duty

SMT63...TENV
SMM63... TENV

SMT63...TEFC
SMM63... TEFC

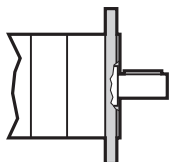
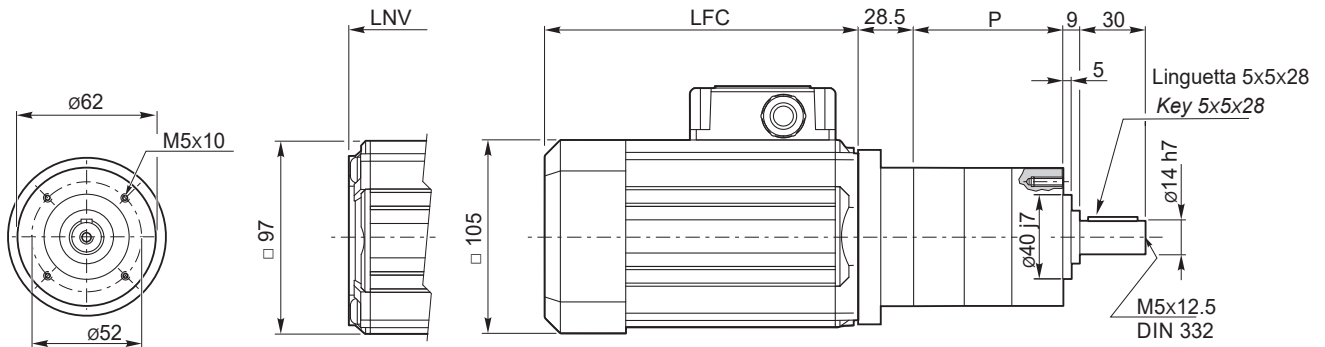

PM62...C

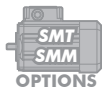

Tipo Type	Numero di stadi Stages number	P
PM62...	1	45.3
	2	62.2
	3	79.2

SMT	LFC	LNV	Kg	
6324	165.5	138.5	5.9	
6334	180.5	153.5	6.6	
6344	205.5	178.5	7.8	

SMM	LFC	LNV	Kg	
6324	180.5	153.5	6.7	
6334	205.5	178.5	7.9	

Nota: il condensatore sarà fornito a corredo
Note: the capacitor will be supplied separately

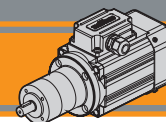

Dimensioni

Dimensions

PM.../... C... Flange uscita / Output flanges

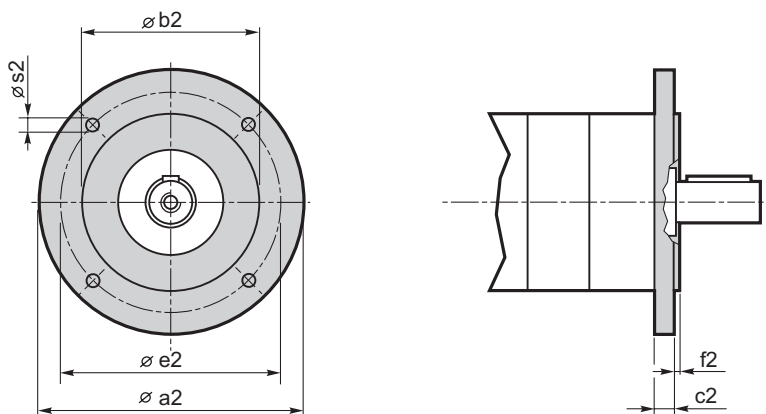

Dimensioni / Dimensions							
PM	a2	b2	c2	e2	f2	s2	Flangia uscita Output flange
52	80	50 j7	9	65	2.5	M5	C80
	90	60 j7	9	75	2.5	5.5	C90
	105	70 j7	9	85	2.5	6.5	C105
	120	80 j7	9	100	3.0	6.5	C120
62	80	50 j7	9	65	2.5	M5	C80
	90	60 j7	9	75	2.5	5.5	C90
	105	70 j7	9	85	2.5	6.5	C105
	120	80 j7	9	100	3.0	6.5	C120

MINI  **TECNO**™
small but strong

WMP

Motoriduttori CA combinati
AC Double reduction gearmotors



MINI  **TECNO**™ brand of
TRANSTECNO®



AC

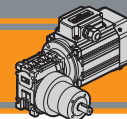

Indice	Index	Pag. Page
Caratteristiche tecniche	<i>Technical features</i>	AM2
Designazione	<i>Classification</i>	AM2
Versioni	<i>Versions</i>	AM2
Simbologia	<i>Symbols</i>	AM3
Lubrificazione	<i>Lubrication</i>	AM3
Carichi radiali	<i>Radial loads</i>	AM3
Rapporti	<i>Ratios</i>	AM3
Dati tecnici	<i>Technical data</i>	AM4
Motori applicabili	<i>IEC Motor adapters</i>	AM5
Dimensioni	<i>Dimensions</i>	AM5

Questa sezione annulla e sostituisce ogni precedente edizione o revisione. Qualora questa sezione non Vi sia giunta in distribuzione controllata, l'aggiornamento dei dati ivi contenuto non è assicurato. **In tal caso la versione più aggiornata è disponibile sul nostro sito internet www.transtecno.com**

This section replaces any previous edition and revision. If you obtained this catalogue other than through controlled distribution channels, the most up to date content is not guaranteed. In this case the latest version is available on our web site www.transtecno.com

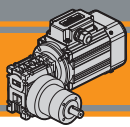

Caratteristiche tecniche

Technical features

Le caratteristiche principali dei motoriduttori WMP sono:

- Costruzione compatta
- Motorizzazioni in corrente alternata monofase e trifase
- Carcassa motore estrusa in alluminio anodizzato nero
- Motore elettrico AC con grado di protezione IP66
- Disponibili sia nella versione ventilata TEFC (servizio S1) che non ventilata TENV (servizio S3)
- Protezione termica PTO 150°C per le taglie motore 56.
- SMT56 adatto al funzionamento con alimentazione da inverter
- Disponibili nelle versioni autofrenante, servovenilata e con certificazione UL.

WMP gearmotors gearmotors have the following main features:

- Compact design
- AC single phase and three phase motors available
- Motor extruded aluminum housing black anodized
- AC electric motor in IP66 protection Standard
- Fan cooled TEFC (duty S1) and not ventilated TENV (duty S3) versions available
- PTO 150°C thermal protection for motor sizes 56.
- SMT56 is suitable for inverter duty
- Brake motors, forced ventilation motors and UL compliance versions available.

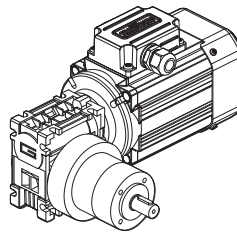

Designazione

Classification

RIDUTTORE / GEARMOTOR					
WMP	026/52	2	C	202.5	56 B14
Tipo Type	Grandezza Size	Numero stadi epicicloidale Planetary stages number	Versione riduttore Gearbox Version	Rapporto Ratio	IEC 56 B14
WMP 	026/52 026/62	1 2 3	US UD CS80...120 CD80...120	Vedere tabella See tables	

MOTORE TRIFASE / THREE PHASE MOTOR									
SMT	56	3	4	0.12 kW	B14	230-400 V	50 Hz	TEFC	T1
Tipo Type	Grandezza Size	Indicativo potenza Power coefficient	Poli Poles	Potenza Power	Forma costruttiva Version	Tensione Voltage	Frequenza Frequency	Ventilazione Fan cooling	Pos. Morsetti Terminal box pos.
SMT 	Vedere tab. See tab.	1-2-3-4	4	0.04 kW ... 0.18 kW	B14	230-400 V 460V	50Hz 60Hz	TEFC TENV	T1 (Std) T4 T2 T3

MOTORE MONOFASE / SINGLE PHASE MOTOR									
SMM	56	3	4	0.12 kW	B14	230 V	50 Hz	TEFC	T1
Tipo Type	Grandezza Size	Indicativo potenza Power coefficient	Poli Poles	Potenza Power	Forma costruttiva Version	Tensione Voltage	Frequenza Frequency	Ventilazione Fan cooling	Pos. Morsetti Terminal box pos.
SMM 	Vedere tab. See tab.	1-2-3	4	0.04 kW ... 0.18 kW	B14	230V	50Hz	TEFC TENV	T1 (Std) T4 T2 T3

Versioni

Versions

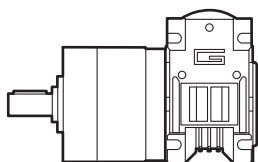

US

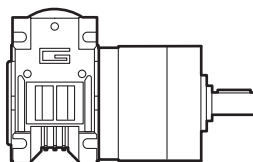

UD

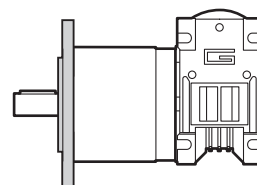

CS

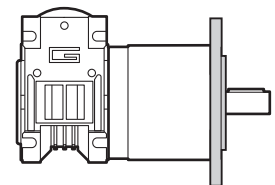

CD

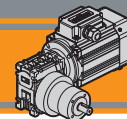

Simbologia

Symbols

n_1 [min ⁻¹]	Velocità in ingresso / <i>Input speed</i>	sf	Fattore di servizio / <i>Service factor</i>
n_2 [min ⁻¹]	Velocità in uscita / <i>Output speed</i>	Rd %	Rendimento dinamico / <i>Dynamic efficiency</i>
i	Rapporto di riduzione / <i>Ratio</i>	A_2 [N]	Carico assiale ammissibile in uscita / <i>Permitted output axial load</i>
P_1 [kW]	Potenza in entrata / <i>Input power</i>	R_2 [N]	Carico radiale ammissibile in uscita / <i>Permitted output radial load</i>
M_2 [Nm]	Coppia in uscita in funzione di P_1 / <i>Output torque referred to P_1</i>		

Lubrificazione

Lubrication

I riduttori epicicloidali sono lubrificati in modo permanente, non richiedono quindi ulteriore manutenzione. Questo gli consente di essere installati praticamente ovunque.

Planetary gearboxes are life-time lubricated with grease, therefore they are maintenance free. They can be installed in any location.

Carichi radiali

Radial loads

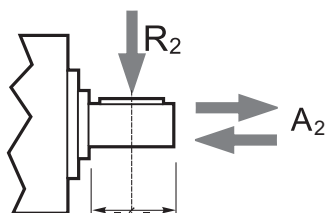

Numero di stadi Stages number	Carichi Radiali R_2 [N] / Radial Load R_2 [N]	
	PM52	PM62
1	200	240
2	320	360
3	450	520

Numero di stadi Stages number	Carichi Assiali A_2 [N] / Axial Load A_2 [N]	
	PM52	PM62
1	60	70
2	100	100
3	150	150

Rapporti



Ratios

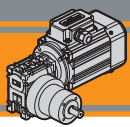

Motoriduttore Gearmotor	Numero stadi epicicloidale Planetary stages number	Rapporto epicicloidale Planetary ratio	Rapporto vite senza fine Wormgearbox ratio	Rapporto finale Total ratio
WMP 026/052 WMP 026/062	1	6.75	10	67.5
			15	101.3
			20	135
			30	202.5
			40	270
			50	337.5
	2	25.01	10	250.1
			15	375.15
			20	500.2
			30	750.3
			40	1000.4
			50	1250.5
			60	1500.6
	45.56	60	2734	



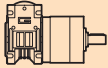

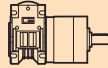

Dati tecnici

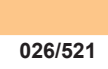

Technical data

P ₁ [kW]	n ₂ [min ⁻¹]	M ₂ [Nm]	sf	i		
0.04						
SMT5014	20.7	12.2	2.0	67.5	026/521	
SMM5014	13.8	17.2	1.4	101.3		
(1400 min ⁻¹)	10.4	21.8	1.1	135		
	6.9	25.0	1.0	202.5		
	5.2	25.0	1.0	270		
	4.1	25.0	1.0	337.5		
	3.5	25.0	1.0	405		
	5.6	25.0	1.0	250.1		026/522
	3.7	25.0	1.0	375.15		
	2.8	25.0	1.0	500.2		
	1.9	25.0	1.0	750.3		
	1.4	25.0	1.0	1000.4		
	1.1	25.0	1.0	1250.5		
	0.9	25.0	1.0	1500.6		
	0.5	25.0	1.0	2734		
	20.7	12.2	3.3	67.5	026/621	
	13.8	17.2	2.3	101.3		
	10.4	21.8	1.8	135		
	6.9	29.2	1.4	202.5		
	5.2	36.0	1.1	270		
	4.1	40.0	1.0	337.5		
	3.5	40.0	1.0	405		
	5.6	42.5	1.2	250.1		026/622
	3.7	50.0	1.0	375.15		
	2.8	50.0	1.0	500.2		
	1.9	50.0	1.0	750.3		
	1.4	50.0	1.0	1000.4		
	1.1	50.0	1.0	1250.5		
	0.9	50.0	1.0	1500.6		
	0.5	50.0	1.0	2734		

P ₁ [kW]	n ₂ [min ⁻¹]	M ₂ [Nm]	sf	i	
0.06					
SMT5024	20.7	18.3	1.4	67.5	026/521
SMM5024	13.8	25.0	1.0	101.3	
(1400 min ⁻¹)	10.4	25.0	1.0	135	
	20.7	18.3	2.2	67.5	026/621
	13.8	25.9	1.5	101.3	
	10.4	32.7	1.2	135	
	6.9	40.0	1.0	202.5	
	5.2	40.0	1.0	270	
	5.6	50.0	1.0	250.1	

P ₁ [kW]	n ₂ [min ⁻¹]	M ₂ [Nm]	sf	i	
0.09					
SMT5034	20.7	25.0	1.0	67.5	026/521
SMM5034					
SMT5624	20.7	27.5	1.5	67.5	026/621
SMM5624	13.8	38.8	1.0	101.3	
(1400 min ⁻¹)	10.4	40.0	1.0	135	
					

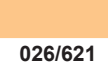
P ₁ [kW]	n ₂ [min ⁻¹]	M ₂ [Nm]	sf	i	
0.12					
SMT5044	20.7	36.7	1.1	67.5	026/621
SMT5634					
SMM5634	13.8	40.0	1.0	101.3	026/622
(1400 min ⁻¹)					
					

P ₁ [kW]	n ₂ [min ⁻¹]	M ₂ [Nm]	sf	i	
0.18					
SMT5644	20.7	40.0	1.0	67.5	026/621
SMM5644					
(1400 min ⁻¹)					
					

N.B.
Verificare sempre che la coppia M₂ utilizzata non ecceda il valore indicato nelle caselle in grigio.

N.B.
Please check that the output torque M₂ does not exceed the value in the grey areas.



Motori Motors	SMT			SMM		
		5014 5024 5034 5044	5624 5634	6324	5024 5034	5624 5634
IEC	56 B14			56 B14		

Dati tecnici elettrici

Electrical technical data



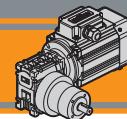

Motori applicabili

IEC Motor adapters

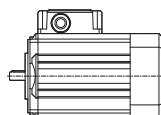

		SMT		SMM	
		5014	5624	5014	5624
		5024	5634	5024	5634
		5034	5644	5034	5644
		5044	5654		
WMP	026/52	67.5 - 2734		67.5 - 2734	
	026/62	67.5 - 2734		67.5 - 2734	

67.5 - 2734

Rapporti di riduzione i
Ratio i

Dimensioni

Dimensions

WMP 026/521
WMP 026/522

SMT50...TEFC
SMM50... TEFC

SMT50...TENV
SMM50... TENV

S3 servizio 30%
duty

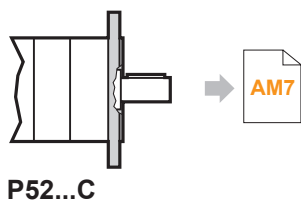
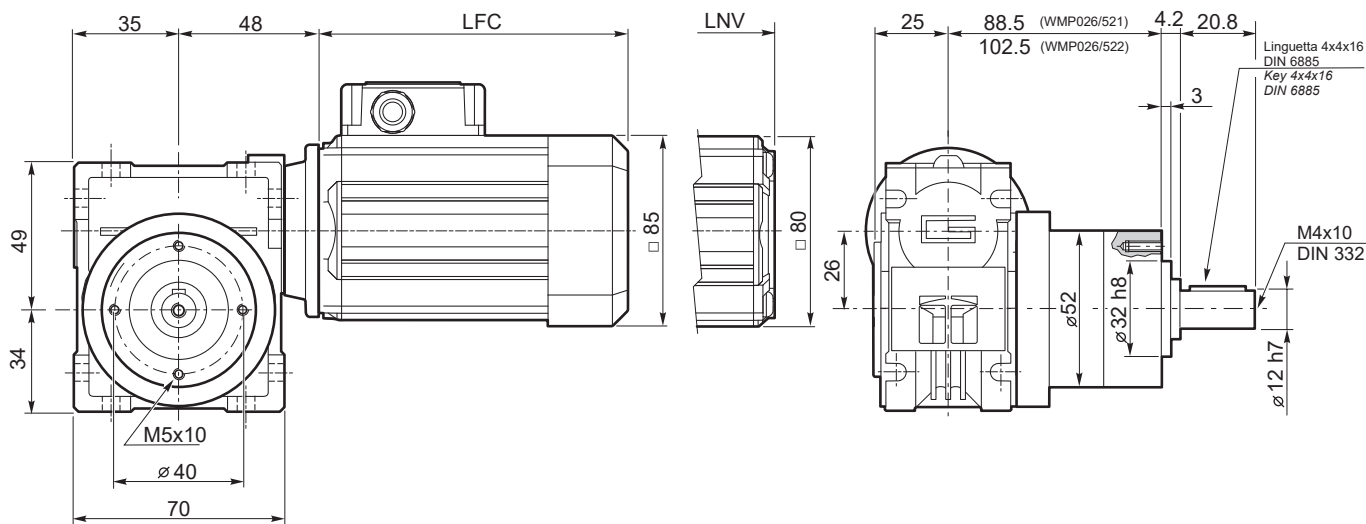

SMT	LFC	LNV	Kg	
5014	135.5	108.5	4.1	
5024	150.5	123.5	4.5	
5034	175.5	148.5	5.3	
5044	200.5	173.5	6	

SMM	LFC	LNV	Kg	
5014	150.5	123.5	4.5	
5024	175.5	148.5	5.3	
5034	200.5	173.5	6	

Nota: il condensatore sarà fornito a corredo
Note: the capacitor will be supplied separately

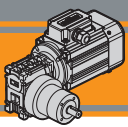

Dimensioni

Dimensions

WMP 026/521
WMP 026/522

SMT56...TEFC
SMM56... TEFC

SMT56...TENV
SMM56... TENV S3 servizio duty 30%

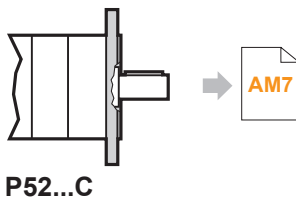
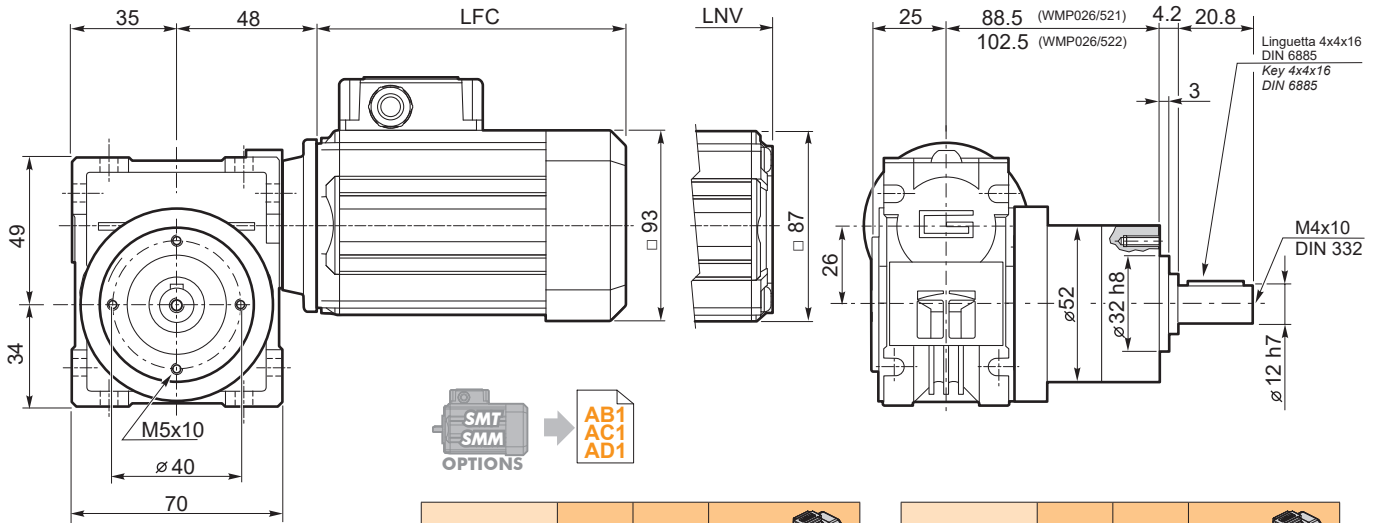

P52...C

SMT	LFC	LNV	Kg	
5624	141	117	4.6	
5634	151	127	5	
5644	186	162	6.2	
5654	206	182	6.9	

SMM	LFC	LNV	Kg	
5624	151	127	4.9	
5634	171	147	5.5	
5644	206	182	6.8	

Nota: il condensatore sarà fornito a corredo
Note: the capacitor will be supplied separately

WMP 026/621
WMP 026/622

SMT50...TEFC
SMM50... TEFC

SMT50...TENV
SMM50... TENV S3 servizio duty 30%

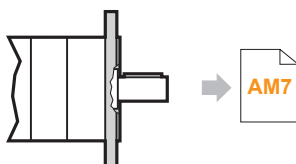
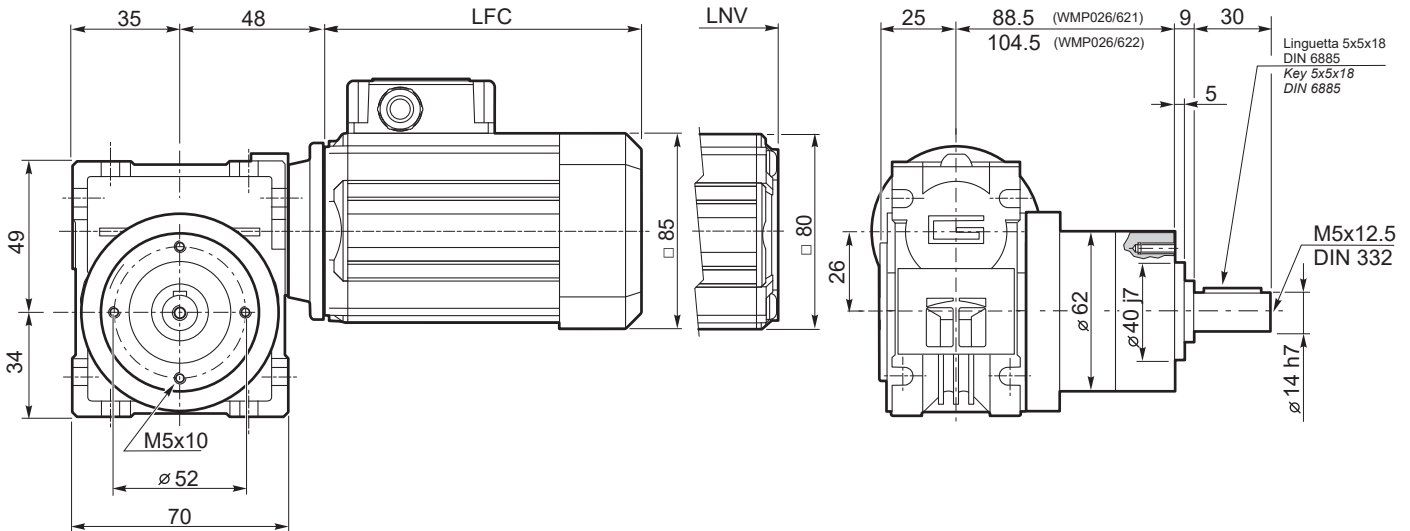

P62...C

SMT	LFC	LNV	Kg	
5014	135.5	108.5	4.4	
5024	150.5	123.5	4.8	
5034	175.5	148.5	5.6	
5044	200.5	173.5	6.3	

SMM	LFC	LNV	Kg	
5014	150.5	123.5	4.8	
5024	175.5	148.5	5.6	
5034	200.5	173.5	6.3	

Nota: il condensatore sarà fornito a corredo
Note: the capacitor will be supplied separately

 **TRANSTECNO SRL**
HEADQUARTERS

Company subject to the management
and coordination of INTERPUMP GROUP SPA
Via Caduti di Sabbiano, 11/D-E
40011 Anzola dell'Emilia (BO)
ITALY
T+39 051 64 25 811
F +39 051 73 49 43
sales@transtecno.com
www.transtecno.com

**TRANSTECNO®**
the modular gearmotor

MEMBER OF INTERPUMP GROUP



 **HANGZHOU TRANSTECNO POWER TRANSMISSIONS CO LTD**
No.4 Xiuyan Road Fengdu Industry Zone
Pingyao Town Yuhang District
Hangzhou City, Zhejiang Province
311115 - CHINA
T +86 571 86 92 02 60
F +86 571 86 92 18 10
info-china@transtecno.cn
www.transtecno.cn

 **MA TRANSTECNO S.A.P.I. DE C.V.**
Av. Mundial # 176, Parque Industrial
JM Apodaca, Nuevo León,
C.P. 66600 - MEXICO
T +52 8113340920
info@transtecno.com.mx
www.transtecno.com.mx

 **TRANSTECNO IBÉRICA THE MODULAR GEARMOTOR, S.A.**
Carrer de la Ciència, 45
08840 Viladecans (Barcelona) - SPAIN
T +34 931 598 950
info@transtecno.es
www.transtecno.es

 **TRANSTECNO B.V.**
Siliciumweg 32
3812 SX Amersfoort - NETHERLANDS
T +31(0) 33 45 19 505
F +31(0) 33 45 19 506
info@transtecno.nl
www.transtecno.nl

 **TRANSTECNO AANDRIJFTECHNIEK B.V.**
Siliciumweg 32
3812 SX Amersfoort - NETHERLANDS
T +31 (0) 33 20 4 7 006
info@transtecnoaandrijftechniek.nl
www.transtecnoaandrijftechniek.nl

 **TRANSTECNO USA**
8 Creek Parkway,
Boothwyn PA 19061-8136 - UNITED STATES
T +1 (610) 4970154
F +1 (610) 497 6085

TRANSTECNO USA – WEST COAST BRANCH
14561 Fryelands Blvd SE
Monroe, WA 98272 - UNITED STATES
T +1 360-863-1300
F +1 360-863-1303
usaoffice@transtecno.com
www.transtecno.com

 **TRANSTECNO CANADA**
51 B Caldari Road Unit 10
Vaughan, ON L4K 4G3 - CANADA
T +1 905 761 0762
F +1 905 761 9265
canadaoffice@transtecno.com
www.transtecno.com

 **TRANSTECNO CHILE-PERU**
Av. Los Libertadores 41
Parque Industrial - Los Libertadores 16.500
Santiago, Colina - CHILE
T +56 2 29633870

Carretera Panamericana Sur KM 29,5,
Interior I-3, Z.I. Lurin - PERU
T +51 1 3546259 / + 51 1 3434231
chileoffice@transtecno.com
www.transtecno.com

 **TRANSTECNO INDIA**
#6A, Sipcot Industrial complex, Phase-1,Elasagiri Road
Hosur – 635126 Tamilnadu - INDIA
T +91 4344 274434
M +91 81443 88800

TRANSTECNO INDIA – NORTH BRANCH
Plot No: 3 A, Sector 2, IIE, Sidcul, Pantnagar
U.S. Nagar, Uttarakhand – 263153 - INDIA
indiaoffice@transtecno.com
www.transtecno.com

 **SALES OFFICE BRAZIL**
Rua Dr. Freire Alemão 155 / 402 - CEP. 90450-060
Auxiliadora Porto Alegre RS - BRAZIL
T +55 51 3251 5447
F +55 51 3251 5447
M +55 51 8111 45 962
braziloffice@transtecno.com
www.transtecno.com.br

 **SALES OFFICE OCEANIA**
Unit 5, 12 Nyholt Drive, Yatala 4207
Queensland - AUSTRALIA
T +61 07 3800 0103
M +61 04 38060997
oceaniaoffice@transtecno.com
www.transtecno.com.au

 **SALES OFFICE SOUTH KOREA**
772-41, Bongdong-ro, Bongdong-eup, Wanju-goon
Chonbuk, 55313
SOUTH KOREA
T +82 70 8867 8897
F +82 504 199 2107
M +82 10 5094 2107
koreaoffice@transtecno.com
www.transtecno.com

www.minitecno.com
www.transtecno.com